



Evolution
MINING

APPENDIX A

Hydrogeological Assessment

**COWAL GOLD OPERATIONS
MINE LIFE MODIFICATION**

Environmental Assessment
2016



Resource
Strategies

8 November 2016

Our ref: GEOTLCOV21910BG-AH

Evolution Mining (Cowal) Pty Limited
PO Box 210
WEST WYALONG NSW 2671

Attention: Bronwyn Flynn

Dear Bronwyn,

Cowal Gold Operations Mine Life Modification

The attached reports present hydrogeological assessments of the proposed Cowal Gold Operations Mine Life Modification (the Modification) for an additional operational life of 8 years, until the end of 2032. The mine is located about 38 kilometres (km) northeast of West Wyalong in NSW.

The reports were prepared for Evolution Mining (Cowal) Pty Limited (Evolution) by Coffey Services Australia Pty Ltd (Coffey). Two companion reports were prepared:

1. One report addressing the operations within the mine lease including operation of the mine pit and the tailings storage facility.
2. A second report addressing the mine water supply borefields within the Bland Creek Palaeochannel Borefield (BCPB) and an Eastern Saline Borefield (ESB). The BCPB and the ESB are located a few kilometres east of the mine.

Evolution proposes to lodge an Environmental Assessment (EA) to facilitate approval of the Modification under section 75W of the New South Wales (NSW) *Environmental Planning and Assessment Act, 1979*.

Based on the attached assessments, it is concluded that:

- Groundwater drawdown due to open pit mining and dewatering are predicted to generally remain within ML 1535 over the life of the mine.
- There would be negligible impact on Lake Cowal and the associated groundwater system due to the open pit, pit dewatering and groundwater extraction from ML 1535 saline groundwater supply borefield.
- Analytes associated with potential seepage from the tailings storage facility are expected to remain within groundwaters between the tailings storage facility and the final void over the long-term.
- Evolution would continue to extract groundwater from the Lachlan River Water Source in accordance with existing licence entitlements, and in accordance with the contingency strategy.

For and on behalf of Coffey

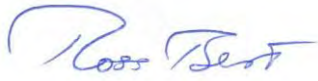

Ross Best
Senior Principal

Attachments

- GEOTLCOV21910BG-AG Cowal Gold Operations Mine Life Modification Mine Site Hydrogeological Assessment
- GEOTLCOV21910BG-BCPB Cowal Gold Operations Mine Life Modification Bland Creek Palaeochannel Borefield and Eastern Saline Borefield Groundwater Assessment

Evolution Mining (Cowal) Pty Limited
Cowal Gold Operations Mine Life Modification
Mine Site Hydrogeological Assessment
10 November 2016

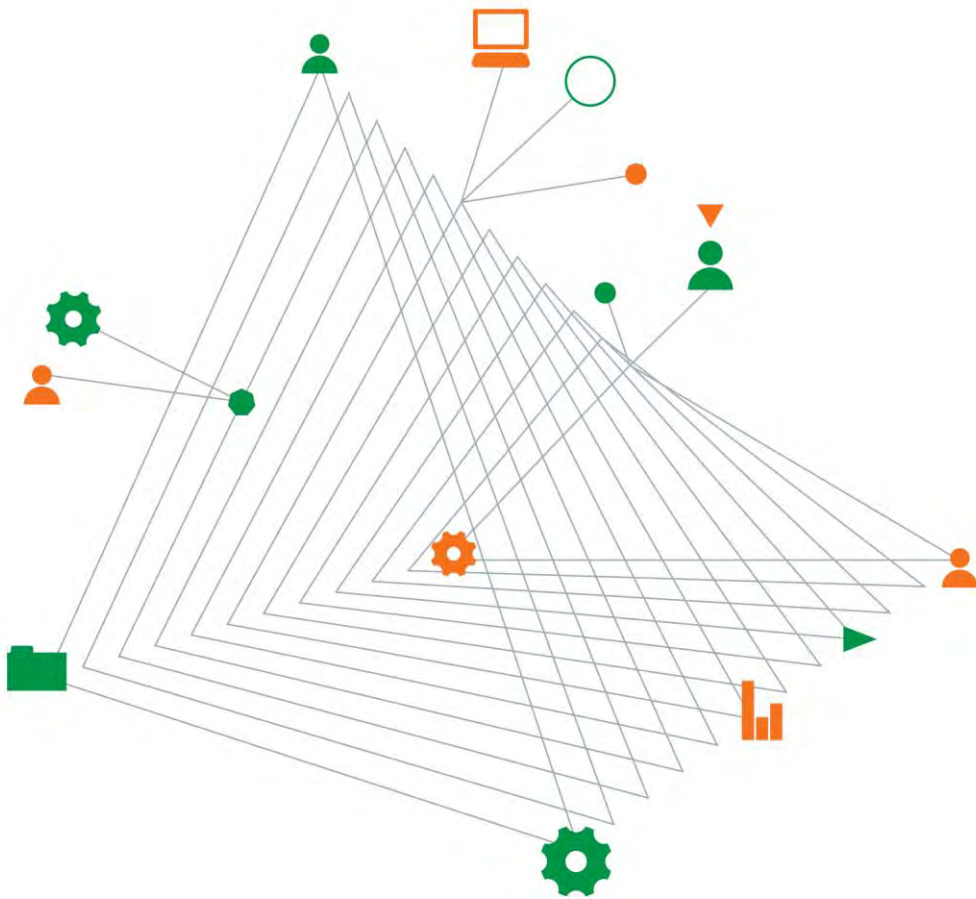

Experience
comes to life
when it is
powered by
expertise

Cowal Gold Operations Mine Life Modification

Prepared for
Evolution Mining (Cowal) Pty Limited
PO Box 210
WEST WYALONG
NSW 2671

Prepared by
Coffey Services Australia Pty Ltd
Level 19, Tower B, Citadel Towers
799 Pacific Highway, Chatswood
NSW 2067 Australia
t: 9406 1000 f: 9406 1002
ABN: 55 139 460 521

10 November 2016

Document authorisation

Our ref: GEOTLCOV21910BG-AG

For and on behalf of Coffey

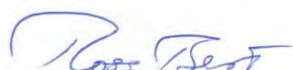

Ross Best
Senior Principal

Quality information

Revision history

| Revision | Description | Date | Author | Reviewer | Signatory |
|-------------|-------------|-------------|-----------------|-----------|-----------|
| Final Draft | | 3 Nov 2016 | Sanka Ekanayake | Ross Best | Ross Best |
| Final | | 10 Nov 2016 | Sanka Ekanayake | Ross Best | Ross Best |

Distribution

| Report Status | No. of copies | Format | Distributed to | Date |
|---------------|---------------|--------|--|-------------|
| Final Draft | 1 | PDF | Bronwyn Flynn (Evolution) Mining [Cowal] Pty Limited | 3 Nov 2016 |
| Final | 1 | PDF | Bronwyn Flynn (Evolution) Mining [Cowal] Pty Limited | 10 Nov 2016 |

| | | |
|----------|---|-----------|
| 1 | INTRODUCTION | 1 |
| 1.1 | Modification Background | 1 |
| 1.2 | Scope of Mine Site Hydrogeological Assessment | 5 |
| 2 | LEGISLATION, POLICY AND GUIDELINES | 8 |
| 3 | DATA REVIEW | 9 |
| 3.1 | Site Layout | 9 |
| 3.2 | Information Sources | 9 |
| 3.3 | Topography | 9 |
| 3.4 | Climate | 11 |
| 3.5 | Surface Drainage | 12 |
| 3.6 | Land Use | 13 |
| 3.7 | Regional Hydrology | 14 |
| 3.8 | Regional Geology | 14 |
| 3.9 | Mine Geology | 15 |
| 3.10 | Regional Hydrogeology | 15 |
| 3.11 | Mine Hydrogeology | 18 |
| 3.12 | Regional Groundwater Levels and Flow Regimes | 20 |
| 3.12.1 | Groundwater Levels | 20 |
| 3.13 | Local Groundwater Levels and Flow Regimes | 21 |
| 3.13.1 | Groundwater Monitoring | 21 |
| 3.13.2 | Groundwater Inflows and Levels within ML 1535 | 23 |
| 3.13.3 | Groundwater Response to Tailings Storage Facilities | 24 |
| 3.14 | Surface Water Bodies | 24 |
| 3.15 | Groundwater Quality | 25 |
| 3.15.1 | Groundwater Quality in ML 1535 | 25 |
| 3.15.2 | Groundwater Contamination in ML 1535 | 25 |
| 3.16 | Aquifer Parameters | 27 |
| 3.16.1 | Tailings Storage Facilities | 32 |
| 3.17 | Representation of Mining Activities | 34 |
| 3.17.1 | Mine Production | 34 |
| 3.17.2 | Excavation Schedule | 36 |
| 3.17.3 | Open Pit Dewatering | 36 |
| 3.17.4 | Storage Dams | 38 |

| | | |
|-----------|--|-----------|
| 3.17.5 | Tailings Storage Facilities | 38 |
| 4 | HYDROGEOLOGICAL MODELLING | 41 |
| 4.1.1 | Model Domain | 41 |
| 4.1.2 | Hydrogeological Units | 42 |
| 4.1.3 | Groundwater Recharge | 43 |
| 4.1.4 | Groundwater Discharge | 43 |
| 4.2 | Numerical Model Development | 43 |
| 4.2.1 | Model Domain, Layers and Discretisation | 43 |
| 4.3 | Model Calibration | 46 |
| 4.3.1 | Model Boundary Conditions | 47 |
| 4.4 | Predictive Groundwater Flow Modelling | 54 |
| 4.4.1 | Modelled Conditions | 54 |
| 4.4.2 | Predictive Modelling Results | 55 |
| 4.5 | Groundwater Quality Related to Open Pit Dewatering | 57 |
| 5 | CONTAMINANT MIGRATION | 58 |
| 5.1 | Seepage from Tailings Storage Facilities | 58 |
| 5.2 | Potential Impact on Groundwater Quality | 58 |
| 6 | GROUNDWATER LICENSING AND AQUIFER INTERFERENCE POLICY CONSIDERATIONS | 60 |
| 6.1 | Licensing | 60 |
| 6.1.1 | Mine Site Groundwater Extraction | 61 |
| 6.2 | Aquifer Interference Policy Requirements | 62 |
| 6.2.1 | Mine Site | 62 |
| 7 | MANAGEMENT AND MITIGATION MEASURES | 64 |
| 7.1 | Groundwater Levels around the Tailings Storage Facilities | 64 |
| 8 | LIMITATIONS | 65 |
| 8.1 | Numerical Simulation | 65 |
| 9 | CONCLUSIONS | 66 |
| 9.1 | Groundwater Impacts due to Open Pit Mining | 66 |
| 9.2 | Impacts on Lake Cowal due to Open Pit Mining | 66 |
| 9.3 | Groundwater Quality Impacts due to Potential Seepage from the Tailings Storage Facilities | 66 |
| 10 | RECOMMENDATIONS | 67 |
| 10.1 | Data and Monitoring | 67 |

11 REFERENCES**68****LIST OF TABLES**

| | |
|----------|---|
| Table 1 | Average Rainfall and Pan Evaporation in the Regional Area |
| Table 2 | Mine Area Monitoring Bore Details |
| Table 3 | Cyanide Detections |
| Table 4 | Adopted Model Parameters (Coffey, 2008) |
| Table 5 | Adopted Model Parameters (Coffey, 2009a) |
| Table 6 | Adopted Model Parameters (Hawkes, 1998) |
| Table 7 | Summary of Horizontal Hydraulic Conductivity Data |
| Table 8 | Summary of Specific Yield and Storage Data |
| Table 9 | Tailings Permeability Data (Knight Piesold Pty Ltd, 1994) |
| Table 10 | Adopted Model Parameters (Coffey, 2009a) |
| Table 11 | Summary of TSF Parameters |
| Table 12 | Indicative Mine Production Schedule |
| Table 13 | Tailings Dam Crest Levels and Low Points |
| Table 14 | Pit Dewatering Bores Used for Transient Calibration |
| Table 15 | Summary of Boundary Conditions Employed in Transient Numerical Model |
| Table 16 | Adopted Model Parameters |
| Table 17 | Expected Dewatering Groundwater Quality |
| Table 18 | Requirements for Water Sharing (Murray-Darling Basin Fractured Rock – Lachlan Fold Belt Groundwater Source) |
| Table 19 | Groundwater Licensing Requirement Summary |

LIST OF FIGURES

| | |
|----------|--|
| Figure 1 | Regional Location |
| Figure 2 | Cowal Gold Operations Location |
| Figure 3 | Modification General Arrangement |
| Figure 4 | Drainage and Topography |
| Figure 5 | Annual and Monthly Rainfall During Mine Life |
| Figure 6 | Lake Cowal Water Levels 2010 to 2016 |

| | |
|-----------|--|
| Figure 7 | Mine Site Geology |
| Figure 8 | Section A-A' through Northern Tailings Storage Facility and Southern Tailings Storage Facility |
| Figure 9 | Section B-B' through Southern Tailings Storage Facility |
| Figure 10 | East West Section through Mine Lease at MGS N6278030 |
| Figure 11 | ML 1535 Groundwater Monitoring Locations |
| Figure 12 | Site layout and Groundwater Monitoring Bore Locations (Pit Area) |
| Figure 13 | Elevation of Base of Open Pit |
| Figure 14 | Pit Dewatering Rates and Rainfall |
| Figure 15 | Interpreted Pit Dewatering Rates |
| Figure 16 | Tailing Storage Facility Water Levels |
| Figure 17 | 3D Representation of Model Domain and Boundary Conditions |
| Figure 18 | Mine Site Numerical Model Mesh |
| Figure 19 | Adopted Water Levels for Lake Cowal |
| Figure 20 | Open Pit Model Seepage Boundary Conditions |
| Figure 21 | Pit Dewatering Rates and Rainfall |
| Figure 22 | Calibration Open Pit Inflows |
| Figure 23 | Model Predicted Inflow to Open Pit |

LIST OF APPENDICES

| | |
|------------|---------|
| Appendix A | Figures |
|------------|---------|

1 INTRODUCTION

This report presents hydrogeological assessment conducted by Coffey Services Australia Pty Ltd (Coffey) for Evolution (Cowal) Mining Pty Limited's (Evolution) Cowal Gold Operations (CGO) Mine Life Modification (the Modification). This report addresses the effects within the mine lease. A companion report has been prepared addressing the effects of mining operations on the outside borefields. The Modification includes the continuation of open cut mining operations at the CGO for an additional operational life of 8 years, until the end of 2032.

Evolution proposes to lodge an Environmental Assessment (EA) to facilitate approval of the Modification under section 75W of the New South Wales (NSW) *Environmental Planning and Assessment Act, 1979* (EP&A Act). A groundwater assessment is required to support the EA.

1.1 Modification Background

Evolution is the owner and operator of the CGO located approximately 38 kilometres (km) north-east of West Wyalong in NSW (Figures 1 and 2).

Mining operations at the CGO are approved to 31 December 2024 and are carried out in accordance with Development Consent DA 14/98 (as modified).

The main activities associated with development of the Modification would include (Figure 3):

- increasing the final depth of the open pit by 70 metres (m) to enable mining of additional ore and an increase in total gold production;
- extending the life of the approved CGO by up to 8 years, to 31 December 2032;
- upgrades to the existing leach circuit within the processing plant to improve gold recovery;
- increasing the total life of mine ore production/volume of tailings and mined waste rock;
- maximising tailings storage capacity of the existing Tailings Storage Facilities (TSFs) via additional lifts and converting the area between the existing TSFs into a new storage area;
- incorporation of a rock fill buttress cover on the outer slopes of the TSF embankments to provide long term stability; and
- an increase to the TSF embankment lift fleet.

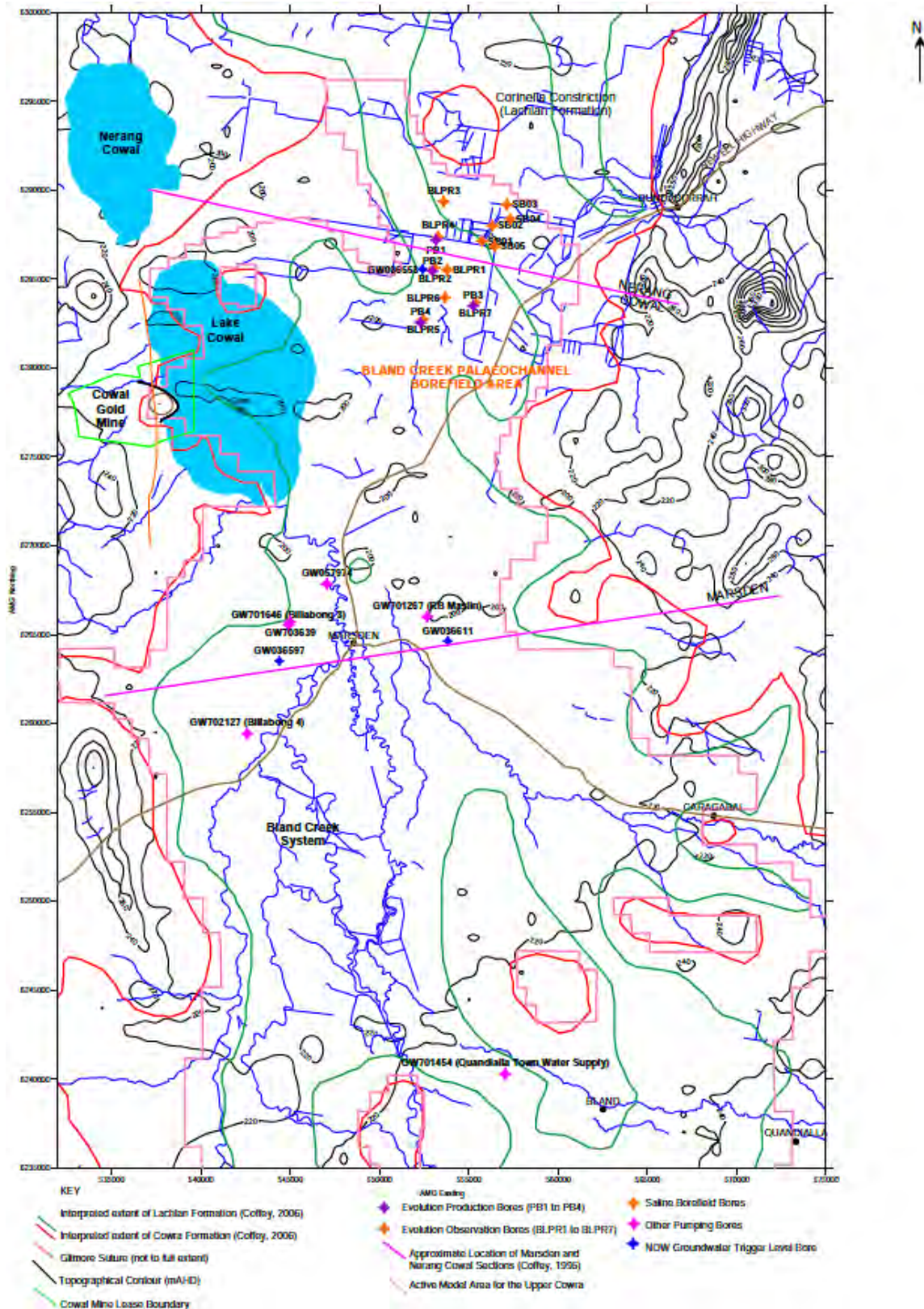

Figure 1 - Regional Location

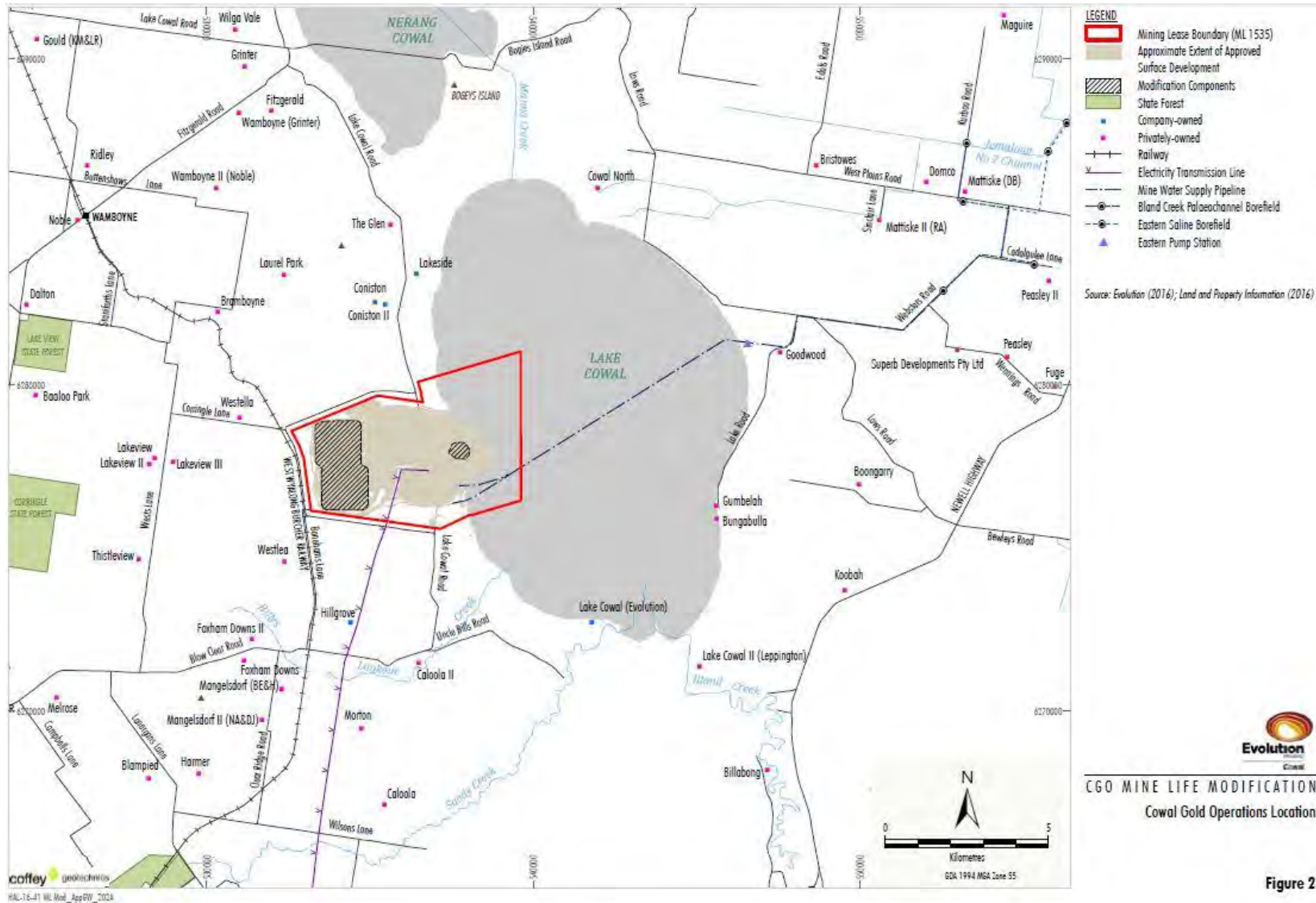

Figure 2 - Cowl Gold Operations Location

Coffey Services Australia Pty Ltd
 CGO Mine Life Modification – Hydrogeological Assessment – Mine Site GEOTLCOV21910BG-AG
 10 November 2016

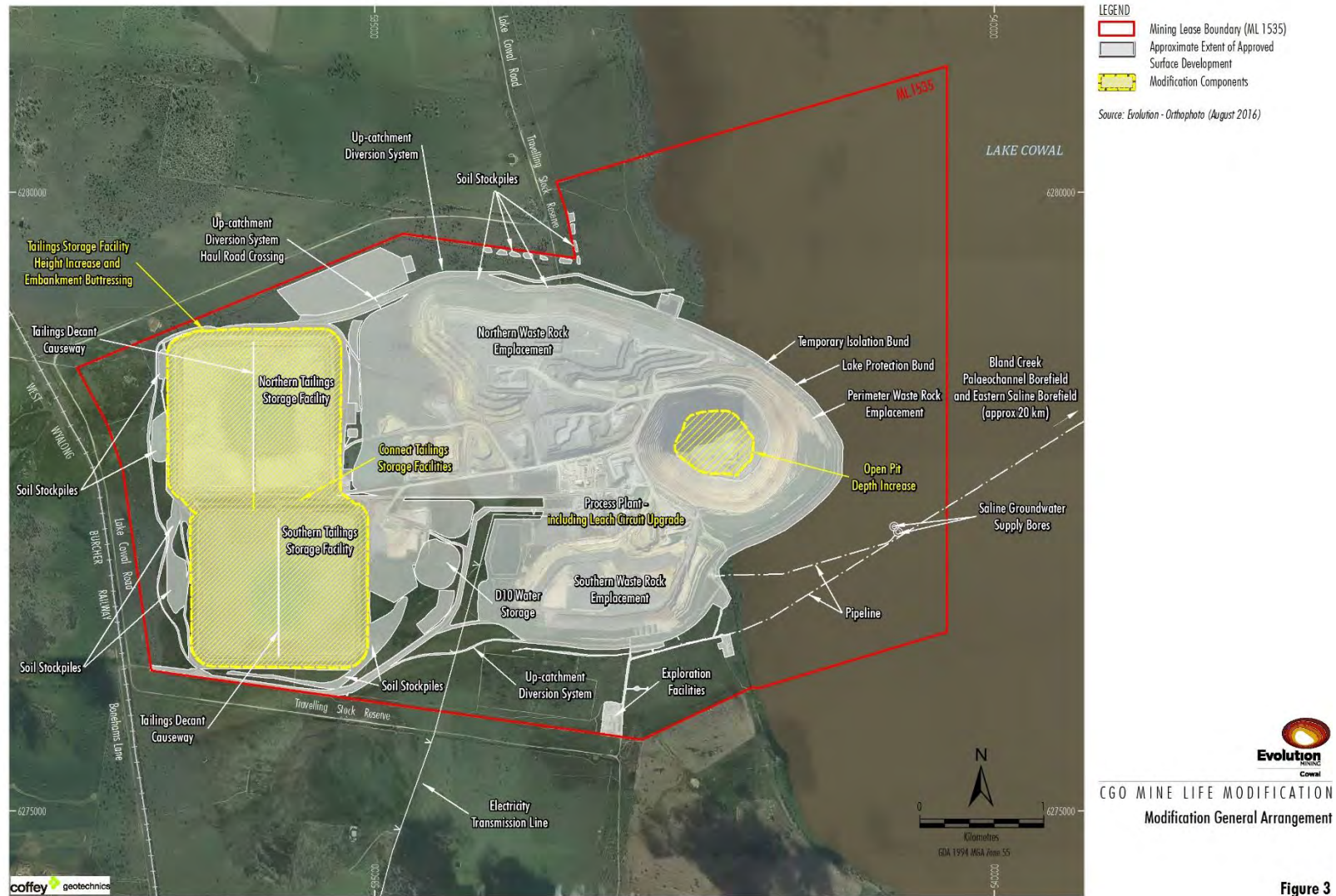

Figure 3 - Modification General Arrangement

Coffey Services Australia Pty Ltd
CGO Mine Life Modification – Hydrogeological Assessment – Mine Site GEOTLCOV21910BG-AG
10 November 2016

The Modification would involve no change to the following key components of the existing CGO:

- mining tenement;
- lake isolation system;
- existing/approved surface development extent of the CGO;
- water management system and design objectives;
- mining methods;
- ore processing rate;
- waste rock emplacement disturbance areas;
- cyanide destruction method;
- approved cyanide concentration limits in the aqueous component of the tailings slurry;
- water supply sources;
- approved daily or annual extraction limits of the Bland Creek Palaeochannel Borefield;
- site access road;
- power supply;
- exploration activities;
- average or peak annual employment;
- hours of operation; or
- TSF embankment construction hours of 7 am to 6 pm.

1.2 Scope of Mine Site Hydrogeological Assessment

This report builds upon work carried out for a groundwater assessment to assess the impacts of the mining operations in relation to changes to the mine associated with an earlier modification. That work considered similar issues to those addressed in relation to the proposed Modification.

The key tasks undertaken for this groundwater assessment comprised:

- Characterisation of the hydrogeological environment, including climate, topography, regional geology, mine geology, regional hydrology and hydrogeology.
- Collation and review of:
 - Groundwater monitoring data, including groundwater level and groundwater quality results from bores located within the mine lease (i.e. proximal to the TSFs facilities, waste rock emplacements and open pit).
 - Past pit dewatering rates and groundwater drawdown monitoring results.

- Identification of Groundwater Dependent Ecosystems (GDEs) in the region, based on the Bureau of Meteorology (BoM) GDE Atlas.
- Identification of data gaps and provision of recommended additional test work/monitoring, if required.
- Consideration of relevant Water Sharing Plans including a summary of water access licences held by Evolution, allocations and the influence of regulatory constraints on use.
- Development of a hydrogeological conceptual model:
 - Selected data for the review.
 - Assesses the need, where relevant, to update the existing mine site numerical model.
 - Proposes modelling approaches to support groundwater impact assessment for the Modification.
- Update of an existing groundwater numerical model of the mine site: Mining Lease (ML) 1535; to incorporate conditions relevant to the Modification, including the extension of the open pit and the raising of the TSFs, more recent groundwater monitoring data and dewatering volume records for the pit, and validation of that model against observation data.
- Predictive modelling to assess the following under the Modification:
 - potential changes to the hydrogeological regime as a result of the increased depth of the open pit under the Modification;
 - potential groundwater drawdown associated with open pit dewatering;
 - expected inflow rates to the open pit;
 - potential seepage rates from the TSFs;
 - groundwater drawdown and flow impacts on Lake Cowal after mine closure, over both the short-term (up to 20 years) and long-term (steady state, potentially hundreds of years into the future after mine closure); and
 - sensitivity analysis in relation to the water levels in Lake Cowal.
- Discussion of the groundwater regime resulting from the Modification and discussion of potential contaminant migration from the TSFs.
- Discussion relating to the open pit and pit dewatering, including:
 - potential changes to the hydrogeological regime as a result of the increased depth of the open pit under the Modification, based on the predictive modelling;
 - expected inflow rates to the open pit, based on the predictive modelling;
 - potential groundwater drawdown associated with open pit dewatering, based on the predictive modelling;
 - Commentary relating to potential drawdown effects against criteria noted in the NSW Office of Water (NOW) *NSW Aquifer Interference Policy* (NOW, 2012);

- qualitative assessment of the expected groundwater quality of water seeping into the open pit; and
- qualitative assessment of impacts on groundwater quality due to pit dewatering.
- Discussion relating to tailings and waste rock emplacement seepage, including:
 - Assessment of predicted seepage rates from the TSFs, based on the predictive modelling. Seepage rates appraised against current performance by comparing model-predicted groundwater levels against monitored groundwater levels in the vicinity of the TSFs.
 - Qualitative assessment of the potential groundwater quality impacts down gradient of the TSFs due to seepage of stored water. Assessed groundwater quality impacts reviewed in the context of groundwater quality monitoring results.
- Discussion relating to mine closure, based on the predictive modelling and including assessment of:
 - The potential groundwater flow impacts on Lake Cowal after mine closure, over both the short-term (up to 20 years) and long-term (steady state, potentially hundreds of years into the future after mine closure).
- Review of groundwater licensing information, including required licenses, allocations and the influence of regulatory constraints, and description of water licensing requirements under the *Water Sharing Plan for the Lachlan Unregulated and Alluvial Water Sources, 2012* and the *Water Sharing Plan for the NSW Murray Darling Basin Fractured Rock Groundwater Sources, 2012*.
- Discussion of potential measures to manage/mitigate/avoid the potential impacts of the Modification on groundwater in the ML and neighbouring areas.

2 LEGISLATION, POLICY AND GUIDELINES

This assessment has been prepared with consideration of the following policies, guidelines and plans:

- *National Water Quality Management Strategy Guidelines for Groundwater Protection in Australia* (Australian and New Zealand Environment and Conservation Council [ANZECC], 1995).
- *NSW Protection of the Environment Operations Act 1997*.
- *The NSW State Groundwater Policy Framework Document* (NSW Department of Land and Water Conservation [DLWC], 1997).
- *NSW State Groundwater Quantity Management Policy* (DLWC).
- *The NSW State Groundwater Quality Protection Policy* (DLWC, 1998).
- *The NSW Groundwater Dependent Ecosystem Policy* (DLWC, 2002).
- *NSW Aquifer Interference Policy* (NOW, 2012).
- *Australian Groundwater Modelling Guidelines* (Barnett *et al.*, 2012).

3 DATA REVIEW

CGO is located within ML 1535 on the western side of Lake Cowal in Central NSW. A regional location plan illustrating topographical contours and the location of regional groundwater extraction bores (both owned by Evolution and privately owned) is presented in Figure 4.

3.1 Site Layout

The CGO site layout is shown in Figure 3.

The following infrastructure and features are present within ML 1535:

- open pit in the east of the site;
- perimeter waste rock emplacement and lake protection bund running beyond, and around, the open pit;
- northern and southern waste rock emplacements to the north-west and south-west of the open pit;
- processing plant located to the west of the open pit;
- a number of contained water storages at various locations across the eastern portion of the site; and
- TSF comprising two storage dams of approximate dimensions 1,300 m by 1,300 m in the west of ML 1535.

3.2 Information Sources

Coffey has a long involvement with the CGO development. This report has been prepared in consideration of the previous reports completed by Coffey and others. Information sources used in development of the hydrogeological conceptual model are listed in References.

3.3 Topography

The region is characterised by a flat landscape with very low undulating hills and occasional rocky outcrops. The majority of vegetation in the area has been cleared, with most of the cleared areas used for agriculture. Remnant and secondary vegetation is restricted to elevated rocky areas (SNC-Lavalin Australia, 2003).

Figure 4 shows the topography and drainage of the area. Ground slopes fall from the north-east (Lachlan Floodplain) and south-east (upper Bland Creek Palaeochannel) towards Lake Cowal. Lake Cowal forms a local depression and fills with flood water every few years. Since 1998, Lake Cowal has filled on three occasions: late 2010, 2012 and again in 2016 (HEC, 2016). It drains north-west towards Nerang Cowal, and eventually to the Lachlan River. Breakout flows from the Lachlan River at Jemalong Gap and drains towards Lake Cowal.

Ground elevations at the mine site range from around 225 m Australian Height Datum (AHD) on the western lease boundary to approximately 200 m AHD at the eastern lease boundary at Lake Cowal. The Bland Creek Paleochannel Borefield area has an elevation of just under 210 m AHD, with minimal variation. Hills formed by rock outcrops on the fringes of the Bland Creek floodplain reach to in excess of 300 m AHD.

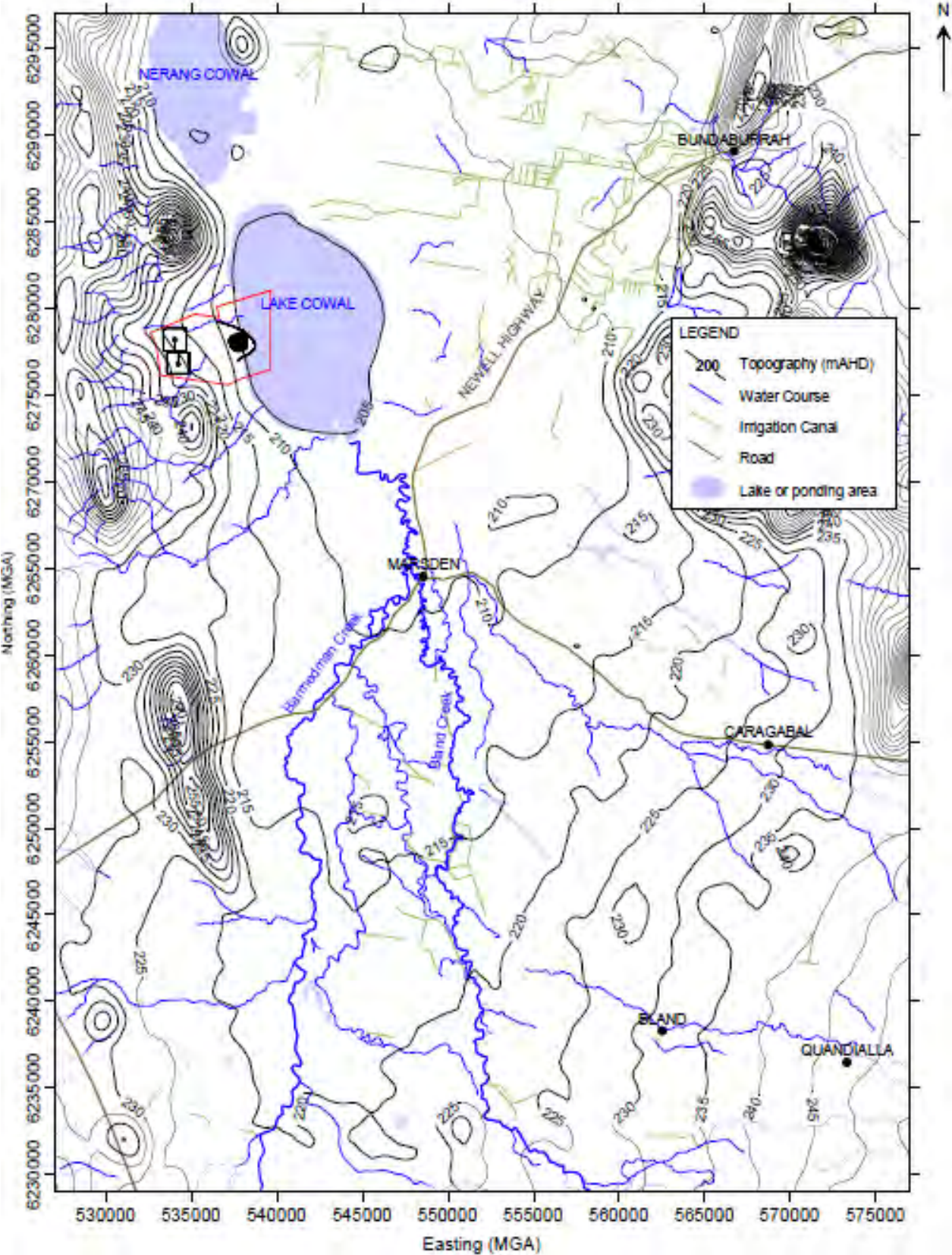

Figure 4 - Drainage and Topography

CGO is located in the Bland Creek Valley, on the western margin of the Bland Creek Palaeochannel Plain, which is approximately 20 to 30 km wide, bounded by the following:

- Bland Creek Palaeochannel and Jemalong Range (Tullamore Syncline) to the east;
- Manna Anticline and its associated ridge, together with the regionally extensive Gilmore Suture/ Gilmore Fault Zone, located to the west of Lake Cowal;
- Lachlan River to the north; and
- Bland Creek catchment to the south.

3.4 Climate

The closest rainfall station to the study area with long-term records is Station 73054 (Wyalong Post Office) operated by the BoM, located approximately 32 km south of ML 1535. This station has no monitoring data between 1939 and 1948. Table 1 lists average and median (Decile 5) monthly rainfall for this station. The average annual rainfall is 479 millimetres (mm). Note that the median annual rainfall is not equivalent to the sum of the monthly median rainfalls.

The closest climate station within 100 km of the site with reasonable amounts of pan evaporation data is BoM Station 050052 (Condobolin Agricultural Research Station), located about 75 km away. Table 1 lists the average monthly pan evaporation for the station over the period 1973 to 2016.

Table 1. Average Rainfall and Pan Evaporation in the Regional Area

| Month | Wyalong Post Office (73054) | | Pan evaporation Condobolin Agricultural Research Station (050052) |
|-----------|-----------------------------|------------------------------------|---|
| | 1895 to 2016 | 1895 to 2016 | 1973-2016 |
| | Mean rainfall (mm) | Decile 5 (median) rainfall (mm) | Mean Total (mm) |
| January | 41 | 27 | 310.0 |
| February | 39 | 22 | 245.8 |
| March | 38 | 23 | 210.8 |
| April | 35 | 25 | 129.0 |
| May | 39 | 31 | 74.4 |
| June | 44 | 37 | 48.0 |
| July | 42 | 38 | 49.6 |
| August | 39 | 39 | 77.5 |
| September | 37 | 29 | 117.0 |
| October | 45 | 37 | 182.9 |
| November | 37 | 31 | 234.0 |
| December | 44 | 31 | 297.0 |
| Annual | 479 | 476 | 1,972 |

Source: BoM (2016).

Average rainfall shows no obvious seasonal trend. Pan evaporation follows a simple sinusoidal trend which is a maximum in January and December. Using average rainfall, a rainfall deficit occurs for all

months of the year except June and July. Average annual pan evaporation is more than three times higher than average annual rainfall (Table 1).

Annual and monthly rainfall from the beginning of mine life (2005) to 2016 at that station is shown in Figure 5. Annual rainfall was significantly above mean annual rainfall for 2010 and 2011 (records for 2016 are incomplete).

The regional annual evaporation totals from the nearest BoM pan evaporation stations as well as average annual open water or lake evaporation was calculated by Gilbert & Associates (2009) using the modified Penman method (Doorenbos and Pruitt, 1977) from CGO weather station records, are as follows:

- 1,972 mm (Condobolin Agricultural Research Station, Station No. 050052, 1973 to 2000).
- 1,569mm (Condobolin Soil Conservation, Station No. 050102, 1971 to 1985).
- 1,388 mm (Cowra Research Station, Station No. 063023, 1965 to 2010).
- 1,919 mm (CGO, 2007 to 2010).

3.5 Surface Drainage

Lake Cowal is an ephemeral shallow freshwater lake that is predominantly dry with water influx during severe rainy seasons (SNC-Lavalin Australia, 2003). The pit envelope encroaches on the lake area and a lake protection bund and groundwater dewatering programme forms an integral part of the mine plan. The lake is filled by runoff from the Bland Creek catchment to the south and flood breakout from the Lachlan River to the north. Lake Cowal is located within the Bland Creek Valley, a major tributary of the Lachlan River system. The lake overflows into Nerang Cowal, another ephemeral lake to the north, and then into Bogandillon Swamp before returning to the Lachlan River. Prior to drought conditions which occurred last decade, the lake was observed to have some water seven years out of ten. Since 1998, Lake Cowal has filled on three occasions: late 2010, 2012 and again in 2016 (Hydro Engineering & Consulting Pty Ltd [HEC], 2016).

Water courses in the area (with the exception of the Lachlan River) are intermittent. Bland and Back Creeks are the largest of the local creeks (Figure 4). They form ephemeral tributaries to Lake Cowal, flowing in from the south. An extensive irrigation canal system is present within the Bland Creek Palaeochannel area and to the north. These canals deliver water from the Lachlan River to irrigators to sustain the agricultural industry in this area.

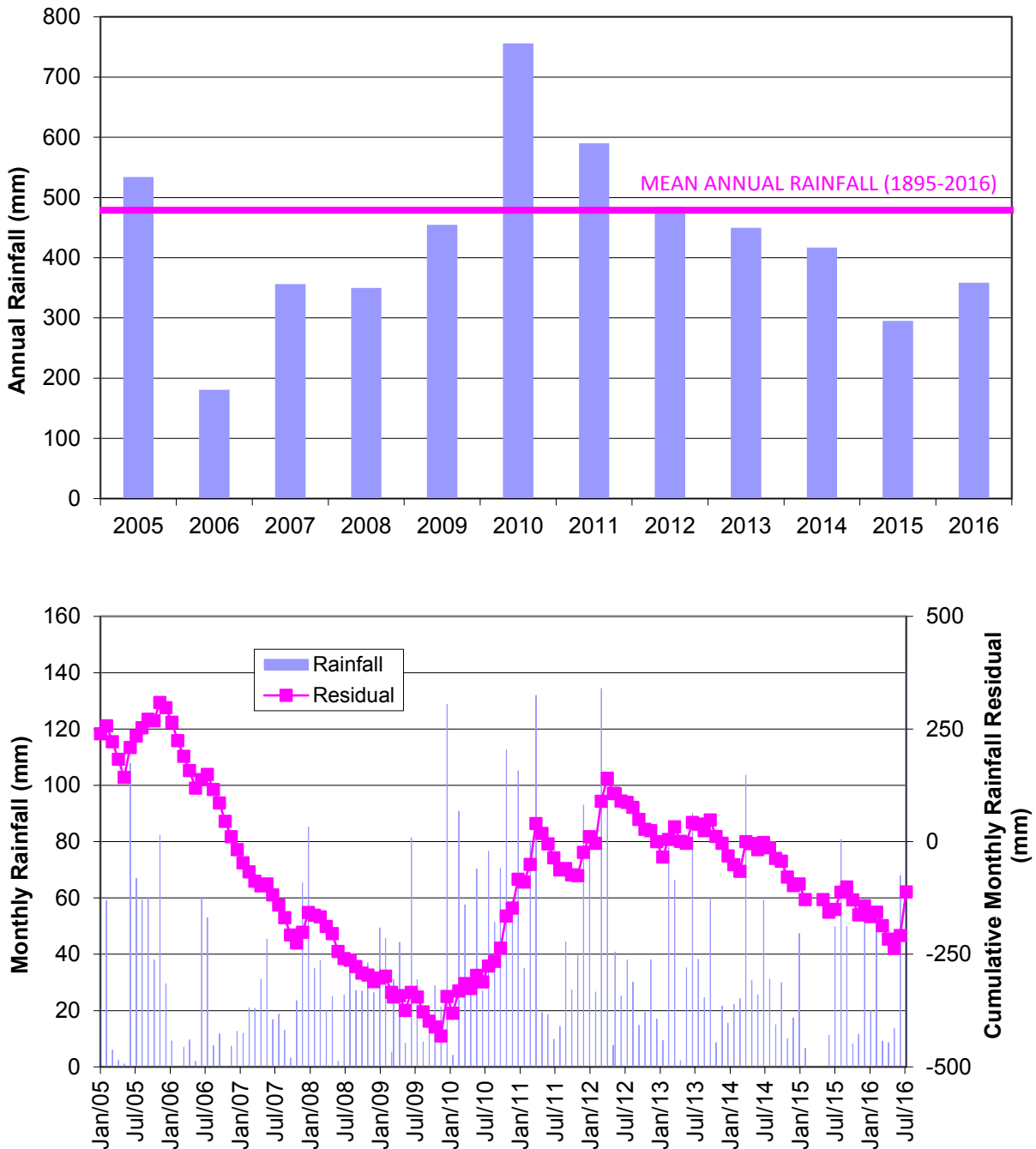

Figure 5 - Annual and Monthly Rainfall during Mine Life (BoM Station 73054).

3.6 Land Use

The Australian Natural Resources Atlas (2009) indicates land use over the region surrounding the CGO site includes livestock grazing, dryland and irrigation agriculture and unclassified water bodies.

Within the Lachlan River Valley, livestock grazing area comprises 69% of land use, followed by dryland agriculture area at 22% and nature conservation area at 4% (Australian Natural Resources Atlas, 2009).

3.7 Regional Hydrology

The Lachlan River is the major regional surface water system, forming part of the Murray-Darling Basin. CGO is located on the western side of Lake Cowal, a fresh water lake within the Bland Creek valley. Lake Cowal receives inflow from:

- Bland Creek, which drains into the lake at its southern end; and
- Lachlan-Lake Cowal floodway to the north-east; when breakout flows from the Lachlan River are directed (during floods) into the north-east section of Lake Cowal.

The lake covers an area of approximately 10,500 ha and holds 150,000 megalitres of water when full. The lake remained dry from the beginning of mine life (early 2005) to mid-2010, when the lake began to fill. Recorded lake water levels are shown in Figure 6.

The lake has a maximum depth of approximately 4 m when full.

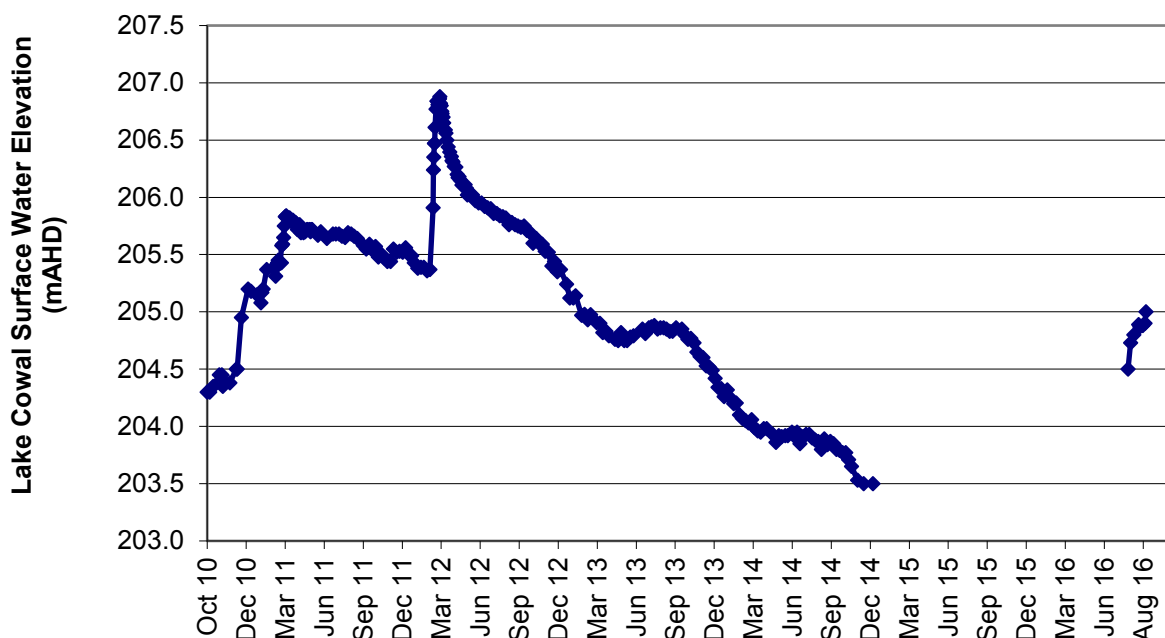

Figure 6 - Lake Cowal Water Levels 2010 to 2016.

3.8 Regional Geology

The Forbes Geological Map (SI55-7, 1:250,000) shows that the regional geological setting is dominated by the Gilmore Fault Zone, a structurally and lithologically complex feature that trends north-south through ML 1535, approximately 500 m west of the CGO open pit.

The fault separates a Late Ordovician volcanoclastic sequence (referred to as the Lake Cowal Volcanic Complex) from Siluro-Devonian sedimentary basement to the west. Siluro-Devonian sedimentary rocks also occur east of the Lake Cowal Volcanic Complex on the eastern side of Lake Cowal, where the basement has been deeply incised and hosts palaeochannel deposits of the Bland Creek unit.

The region is covered by varying thicknesses of Tertiary and Quaternary regolith deposits. The Bland Creek Palaeochannel Plain was formed by the infilling of the Lachlan and Bland Creek Palaeochannels, located to the north and east of Lake Cowal respectively, with sediments of the Lachlan and Cowra

Formations. The depth of these sediments is over 100 m. Locally, Pleistocene Cowra alluvium overlies ML 1535 and thick Quaternary lacustrine sediments underlie Lake Cowal.

3.9 Mine Geology

The CGO site lies within the Lake Cowal Volcanics, which comprise massive and stratified non-welded pyroclastic debris, overlying a partly brecciated lava sequence, overlying volcanic conglomerate interbedded with siltstone and mudstone. The host rock has a consistent strike of 215 degrees (°) and an approximate dip of 50° to the north-west.

Within the Lake Cowal Volcanic Complex are diorite and gabbro intrusions, one of which is intersected by the CGO open pit. Within the ore body there are several north-south oriented, near vertically dipping faults and fractured dykes.

Overlying the Ordovician host rock (Saprock and Primary) is a Tertiary age laterite (Saprolite), which averages approximately 20 m and varies in thickness across the CGO site from approximately 15 m to 55 m. Quaternary age sediments of predominantly lacustrine clay (Transported Alluvium) characteristically cover the Tertiary laterite. The depth of sediments across the CGO site and surrounds ranges from approximately 14 m to 55 m. This is consistent with thickness of the Transported Alluvium (Lower Cowra and Upper Cowra Formations) utilised in a calibrated groundwater model developed by NOW (now DPI Water), in which values of over 20 m were adopted over the CGO site and surrounds.

The geology of the CGO site and surrounds is illustrated in Figure 7.

3.10 Regional Hydrogeology

Regionally, groundwater resources are present in the Bland Creek Palaeochannel, which include the following two geological formations:

- **Cowra Formation:** comprises isolated sand and gravel lenses in predominantly silt and clay alluvial deposits, with groundwater of generally higher salinity; and
- **Lachlan Formation:** comprises quartz gravel with groundwater of generally low salinity.

Figure 1 shows the interpreted extent of the Cowra and Lachlan Formations as assessed by Coffey (2006).

Three distinct alluvial sequences were interpreted to be present based on the distribution of hydraulic conductivity with depth assessed by Coffey (2006). These are as follows:

- **Upper Cowra Formation:** this sequence generally occurs from ground surface to an average depth of approximately 45 m to 50 m over most of the CGO site and surrounding area. The average depth to groundwater is approximately 7 m, giving an average saturated thickness of just over 40 m (Coffey, 2006). The data suggest the Upper Cowra sequence generally shows decreasing hydraulic conductivity with depth and greater stratification than deeper layers.
- **Lower Cowra Formation:** this sequence generally occurs over an average depth interval of approximately 50 m to 90 m over most of the CGO site and surrounding area. This layer appears to have lower horizontal hydraulic conductivity values than the Upper Cowra Formation.
- **Lachlan Formation:** this sequence generally occurs over an average depth interval of around 90 m to 120 m in the Bland Creek Palaeochannel. Within this formation there were assessed to be two distinct sequences, including:

- High permeability sands and minor gravels close to and within the deeper parts of the palaeochannel.
- Lower permeability sediments that generally occur further away from the deeper parts of the palaeochannel and surround the high permeability sands and minor gravels. The average hydraulic conductivity of this sequence appears similar to the Lower Cowra Formation.

Coffey (2006) interpreted that the western limit of the Cowra Formation extends within the eastern boundary of ML 1535, but that the Lachlan Formation did not extend into ML 1535. Pre-mining groundwater flow was generally from east to west under a hydraulic gradient of approximately 0.1%, increasing to 0.3% further west.

Geological data available from the off site borefield used to provide part of the mine water requirements (the Bland Creek Palaeochannel Borefield) to the north-east and for the Bland Creek system to the south-east of the CGO site have also been used in characterising the regional hydrogeology.

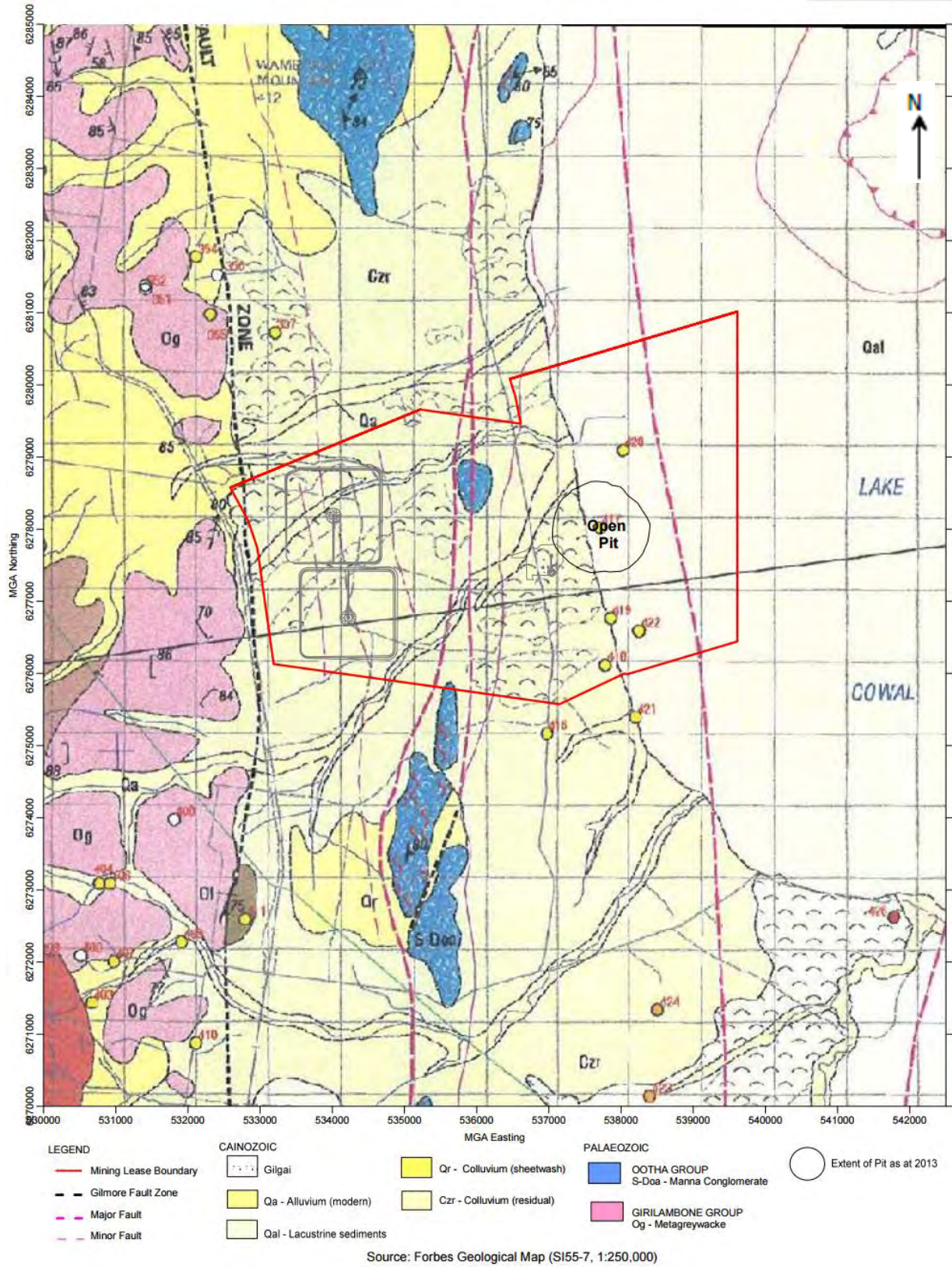

Figure 7 – Mine Site Geology.

3.11 Mine Hydrogeology

Coffey (2009a) developed geological cross-sections through the western area of the CGO site. The locations of the cross-sections are shown on Figure 3 and the cross-sections are shown on Figure 8 and 9. The extent of the Saprolite and Saprock units outside the CGO site are not defined. Figure 8 shows a section along north-south direction while Figure 9 shows a section along east-west direction.

Figure 10 presents a simplified conceptual cross-section through approximately the centre of the CGO open pit (at Map Grid of Australia [MGA] N6,278,030).

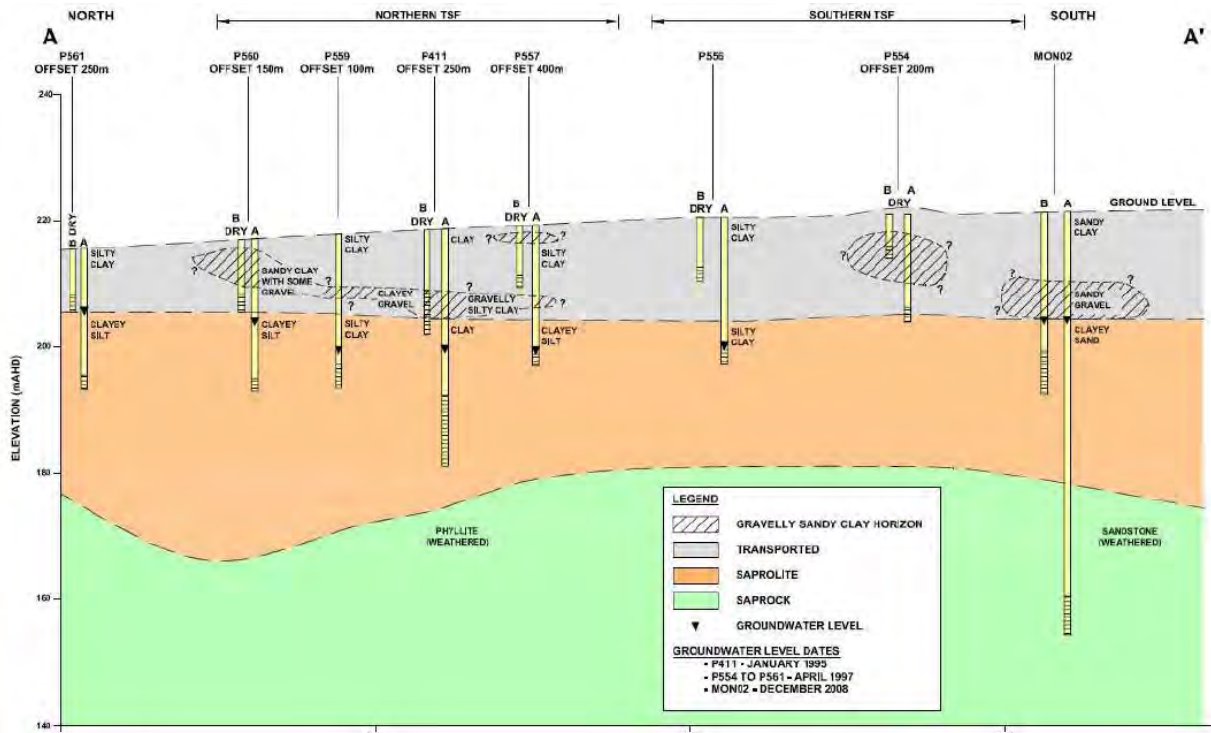

Figure 8 – Section A-A' through Northern Tailings Storage Facility and Southern Tailings Storage Facility.

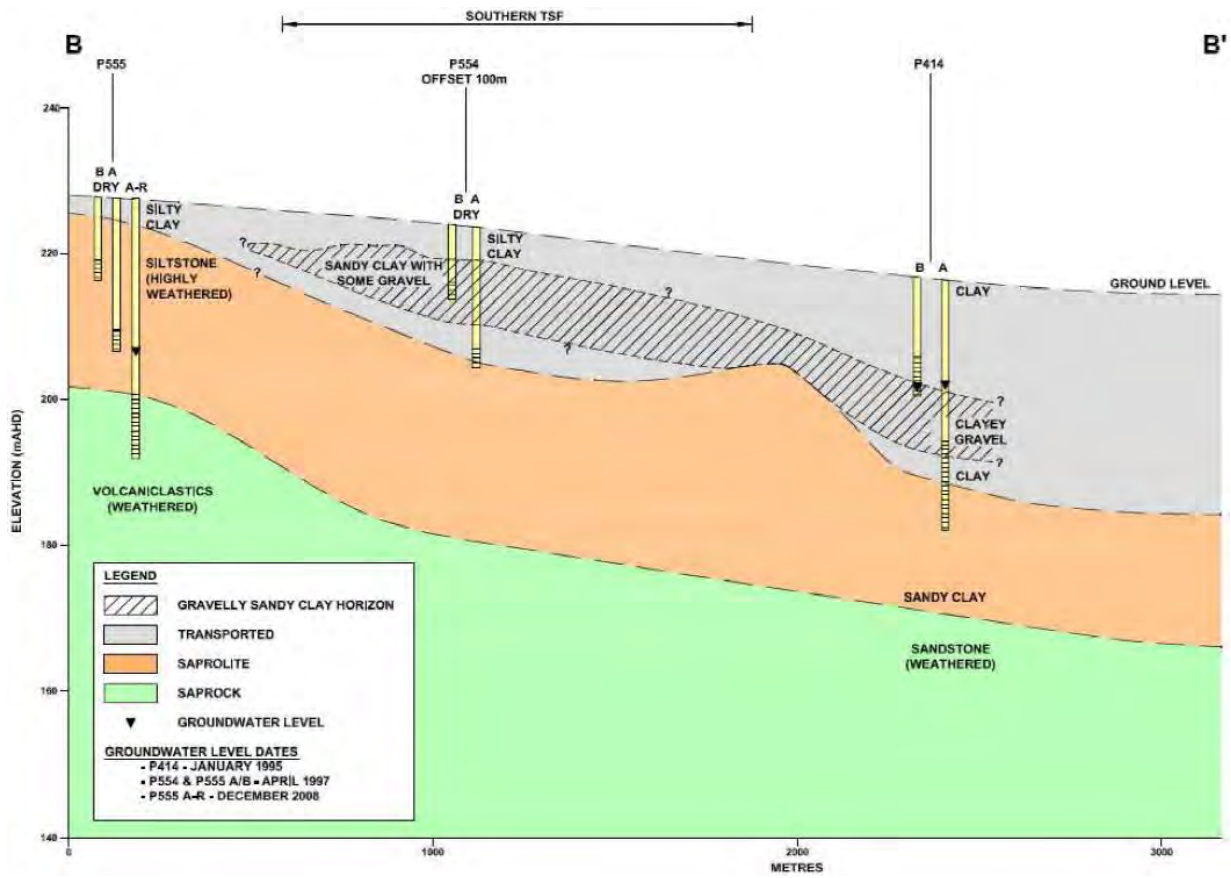

Figure 9 – Section B-B' through Southern Tailings Storage Facility.

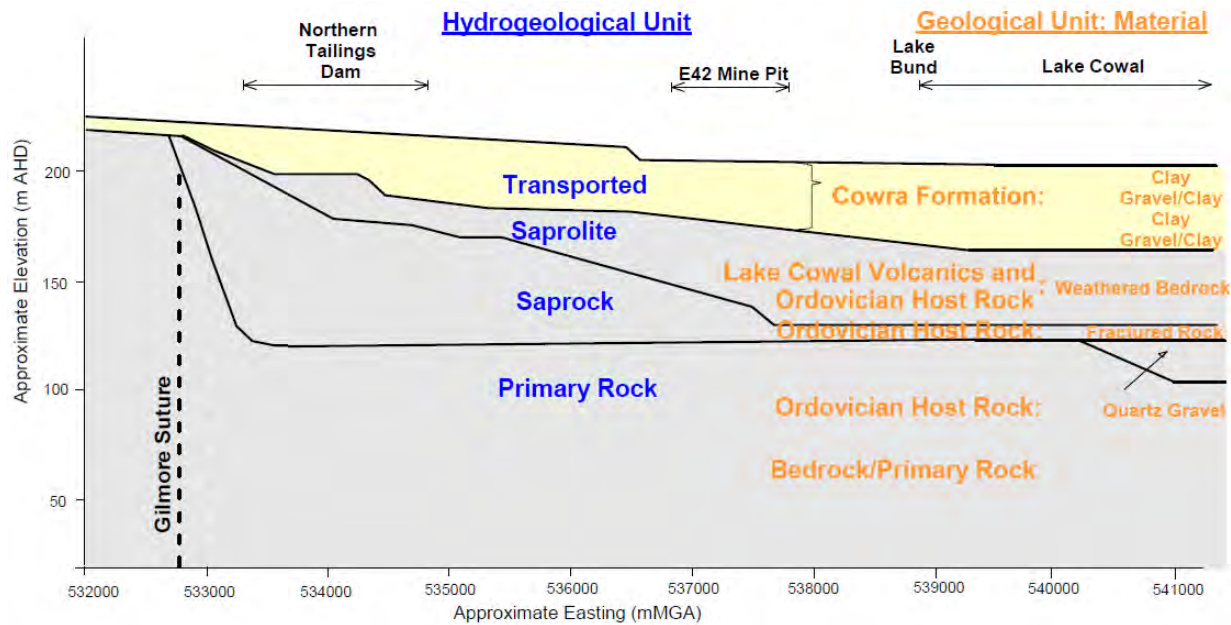

Figure 10 – East West Section through Mine Lease at MGS N6278030.

Locally at the CGO site, four hydrogeological units have been identified:

- The Transported hydrogeological unit comprises alluvium (thick clay sequences and more permeable zones of gravel within a sandy clay matrix) of the Quaternary aged Cowra Formation. The Cowra Formation is laterally equivalent to the Transported unit [Barrick (mine owner at the time), 2010]. (In prior reports and literature, this unit is often termed the Transported Alluvial Aquifer).
- The Saprolite hydrogeological unit underlies the Transported unit, and is of relatively low hydraulic conductivity.
- The Saprock hydrogeological unit underlies the Saprolite unit, and occurs in the weathered fractured surface of the Lake Cowal Volcanics.
- More massive and less permeable Bedrock/Primary Rock underlies the Saprock unit.

The Saprolite, Saprock and Bedrock/Primary Rock are considered to be within the fractured rock groundwater system. Surfaces of topographic (ground surface) elevations and the base elevations of the Transported, Saprolite and Saprock hydrogeological units were provided by Barrick, the former mine owner, for the ML 1535 area, and were updated by Coffey (2012) with additional drilling data provided by Barrick.

The surfaces of the hydrogeological units were linearly extrapolated from the boundaries of ML 1535 to regions outside ML 1535, with the following considerations:

- Interpolation between the geological cross-sections shown on Figures 8, 9 and 10, based on Coffey (2009a), and data for the CGO open pit and surrounding area (Coffey, 2008) (interpolation between approximately MGA E535500 and MGA E536800).
- The Cowra Formation is laterally equivalent to the Transported unit and the regional interpretation of this unit was adopted from the modelling work carried out for the Bland Creek Palaeochannel.
- Data for the top of bedrock (equivalent to the top of Primary Rock), covering from the eastern side of the CGO site to the eastern boundary of the model domain. The bedrock (Primary Rock) outcrops at the surface along the Gilmore Suture and at Cowal West Hill (Coffey, 1995a).
- The Gilmore Suture marks a geological divide to the west of which the Primary Rock is the only unit underlying the Transported unit.

Figures showing the model adopted surface contours for ground surface level, and the base of the Transported, Saprolite and Saprock units, respectively, over the mine site area are presented in Appendix A, Figure A-1 to A-4.

3.12 Regional Groundwater Levels and Flow Regimes

3.12.1 Groundwater Levels

Regional groundwater levels are discussed in a companion report on the modelling of the Bland Creek Palaeochannel Borefield (Coffey 2016). The groundwater conditions in the vicinity of the CGO are controlled by more local factors and are not linked to changes in the deep alluvial system forming the Bland Creek Palaeochannel aquifer system.

3.13 Local Groundwater Levels and Flow Regimes

3.13.1 Groundwater Monitoring

The installation details for active groundwater monitoring piezometers within ML 1535 are shown in Table 2. Piezometers with the suffix 'A' are the deeper of paired piezometers (typically screened in the Saprolite/Saprock unit), while those with suffix 'B' are shallower (typically screened in the Transported unit). The location of these piezometers is shown in Figures 11 and 12.

Groundwater monitoring records for these piezometers are shown in Figure A-5 (Appendix A). Records for piezometers P555A, P555B and P412B show those piezometers have remained dry over the mine life and are therefore not shown in the Figures. Piezometers PDB4A and PDB4B were decommissioned in September 2009.

Table 2. Mine Area Monitoring Bore Details

| Area | Piezometer Name | Screened Stratum | Top of Casing (m AHD) | Depth (m below ground level) | Screen Intervals (m below ground level) |
|-----------------|-----------------|------------------|-----------------------|------------------------------|---|
| Pit Area | PDB1A | Saprock | 208.26 | 88 | 82 to 88 |
| | PDB1B | Transported | 208.23 | 20 | 14 to 20 |
| | PDB3A | Saprock | 204.80 | 100.5 | 94.5 to 100.5 |
| | PDB3B | Transported | 204.82 | 29.6 | 23.6 to 29.6 |
| | PDB4A | Saprock | 204.84 | 80 | 74 to 80 |
| | PDB4B | Transported | 204.84 | 30.5 | 24.5 to 30.5 |
| | PDB5A | Saprock | 209.05 | 82.5 | 76.5 to 82.5 |
| | PDB5B | Saprolite | 208.82 | 29.8 | 23.8 to 29.8 |
| Processing Area | PP01 | Transported | 215.61 | 25 | 13 to 25 |
| | PP02 | Transported | 213.00 | 18.5 | 8.5 to 18.5 |
| | PP03 | Saprolite | 213.52 | 51 | 31 to 51 |
| | PP04 | Transported | 213.89 | 19.5 | 10.5 to 19.5 |
| | PP05 | Transported | 214.18 | 20 | 11 to 20 |
| | PP06 | Transported | 214.03 | 20 | 11 to 20 |
| Tailings Areas | P555A | Saprolite | 227.41 | 19.8 | 17.8 to 19.8 |
| | P555A-R | Saprock | 227.35 | 36 | 27 to 36 |
| | P555B | Saprolite | 227.41 | 10 | 8 to 10 |
| | P558A-R | Saprolite | 224.29 | 42.6 | 30.6 to 42.6 |
| | P412A | Saprolite | 216.15 | 30 | 18 to 30 |
| | P412A-R | Saprolite | 216.12 | 61 | 55 to 61 |
| | P412B | Transported | 216.09 | 16 | 10 to 16 |
| | P414A | Saprolite | 217.05 | 34 | 22 to 34 |
| | P414B | Transported | 217.07 | 16 | 10 to 16 |
| | P417A | Saprolite | 216.49 | 36 | 24 to 36 |
| | P417B | Transported | 216.47 | 14 | 8 to 14 |
| | P418A | Saprolite | 214.23 | 32 | 20 to 32 |
| | P418B | Transported | 214.22 | 16 | 10 to 16 |
| TSFNA | Saprock | 215.28 | 98 | 92 to 98 | |

Table 2 (Continued). Mine Area Monitoring Bore Details

| Area | Piezometer Name | Screened Stratum | Top of Casing (m AHD) | Depth (m below ground level) | Screen Intervals (m below ground level) |
|----------------------|-----------------|------------------|-----------------------|------------------------------|---|
| Tailings Areas | TSFNB | Transported | 215.19 | 30.1 | 24.1 to 30.1 |
| | TSFNC | Transported | 215.27 | 18 | 12 to 18 |
| | MON01A | Saprock | 215.26 | 69 | 63 to 69 |
| | MON01B | Transported | 215.29 | 15 | 9 to 15 |
| | MON02A | Saprock | 222.48 | 69 | 63 to 69 |
| | MON02B | Saprolite | 222.44 | 30 | 24 to 30 |
| | P561A | Saprolite | 215.06 | 23 | 21 to 23 |
| | P561B | Transported | 215.05 | 10 | 8 to 10 |
| Lake Protection Bund | PBP1 | Transported | 209.57 | ~12 to 13 | Assumed 6 to 12 |
| | PBP2 | Transported | 209.37 | 11.7 | |
| | PBP3 | Transported | 209.43±0.2 | 10.4 | |
| | PBP4 | Transported | 209.48 | ~12 to 13 | |
| | PBP5 | Transported | 209.62 | ~12 to 13 | |

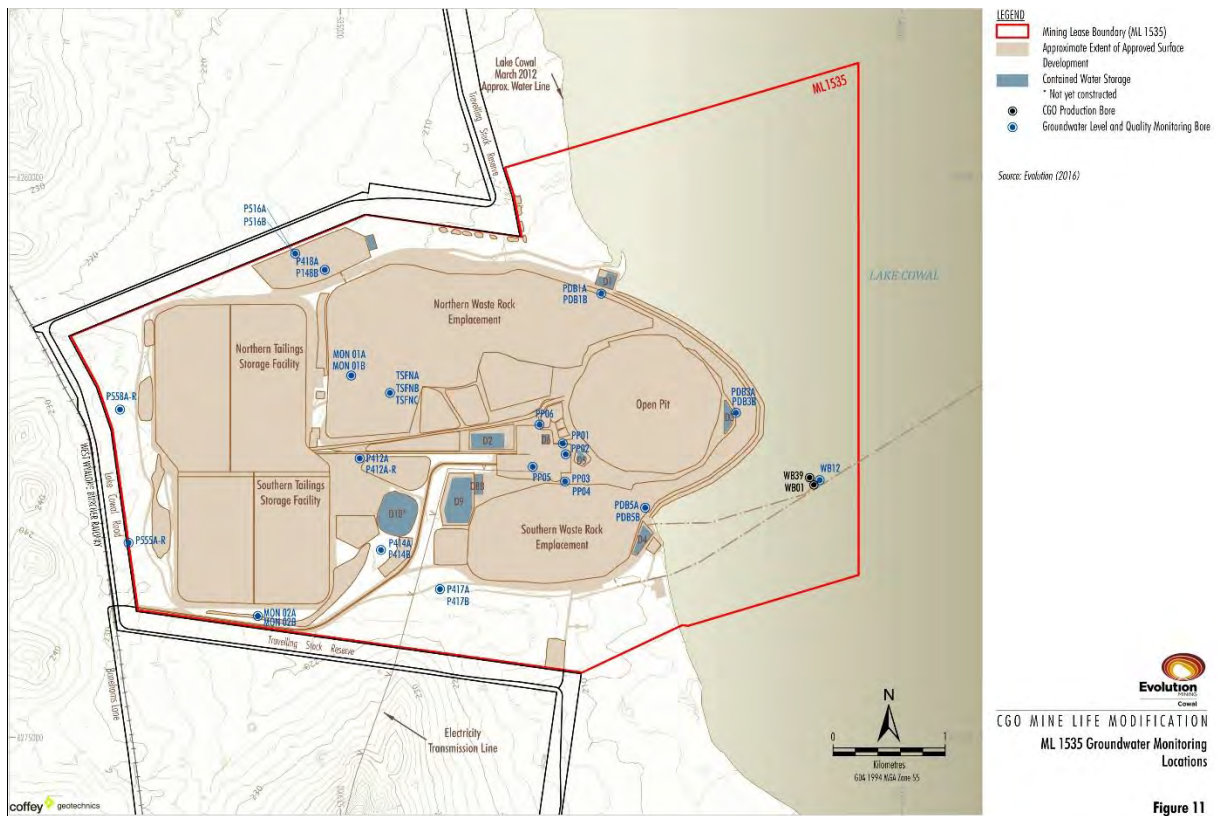

Figure 11 – ML 1535 Groundwater Monitoring Locations.

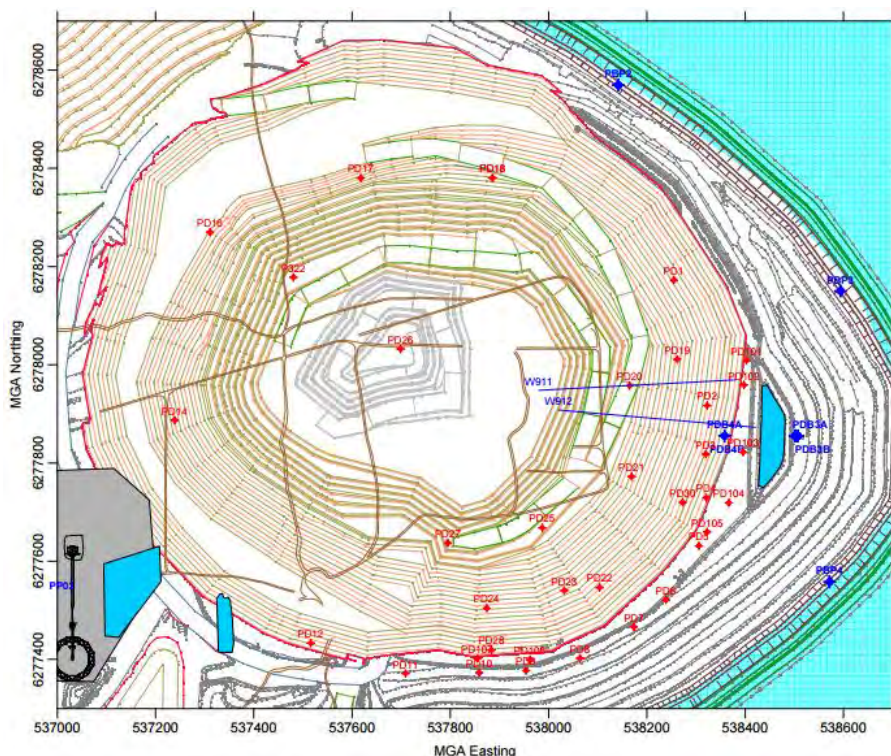

Figure 12 – Site Layout and Groundwater Monitoring Bore Locations (Pit Area).

3.13.2 Groundwater Inflows and Levels within ML 1535

Over the life of the mine, Lake Cowal remained dry until June 2010 when significant rainfall caused the lake to begin to fill with water. It has continued to hold water to mid-2014 until drying up in late 2014. It began to fill with water with again with the significant rainfall in mid-2016. Since the commencement of the CGO, the underlying aquifers surrounding and intercepting the open pit have been depressurised as a result of the inflows to the open pit and active pit dewatering. Despite Lake Cowal becoming inundated, groundwater inflows to the open pit are assessed (considering rainfall runoff) to have remained below (or consistent with) historical records and relatively stable. This is most likely because the lacustrine sediments that form the lake bed have a very low vertical permeability and act as an aquitard (low permeability layer) between lake water and underlying aquifers (Coffey, 1997).

The open pit groundwater inflow observations confirm the finding of Coffey (1997) that the long term leakage from the lake (when containing water) to underlying aquifers would be very small and not measureable.

It is relevant to note that the groundwater level in piezometer PDB3A fell significantly in March 2011. This corresponds to the date of installation of horizontal drains W911 (passing within 30 m of PDB3A) and W912 (passing within 110 m of PDB3A), both of which reported significant groundwater flows immediately following installation (600 cubic metres per day [m³/day] and 170 m³/day, respectively). It is likely that the groundwater level in piezometer PDB3A has been significantly impacted by pit dewatering since March 2011.

3.13.3 Groundwater Response to Tailings Storage Facilities

Groundwater monitoring records for piezometers in the vicinity of the TSF are shown in Figure A-6 (Appendix A).

Groundwater levels in the Transported, Saprolite and Saprock units in the vicinity of the TSF show a progressive rise since CGO began operating. Generally, the magnitude of the groundwater rise correlates with the distance of the monitoring bore from the TSF. For example, in the Transported unit, the groundwater level rise at bore P414B, which is relatively close to the TSF, is greater than that at bore TSFNB, located further away. Similarly, in the Saprock unit, bore MON02A has displayed a significant rise since late 2006, whilst the magnitude of groundwater level rise at bore MON01A (located at a greater distance from the TSFs) is lower.

Groundwater levels in piezometers MON02A and MON02B (screened in the Saprock and Saprolite, respectively) have displayed a significant rise since late 2006. Groundwater level variation around the TSFs was investigated by Coffey (2016). Rises were assessed to be related to the percolation and the movement of seepage from the TSFs.

Note that modelling carried out for the Cowal Gold Project Environmental Impact Statement (EIS) (North Limited, 1998) showed groundwater level rise around the tailings impoundments to near the ground surface under some assumptions in relation to hydraulic properties of the soil profile and tailings dam materials (EIS Appendix N – Attachment N2-A of the EIS). The results at MON02A and MON02B are consistent with this possibility. Well established measures can be used to control groundwater levels approaching the surface including use of drainage trenches.

3.14 Surface Water Bodies

Records of Lake Cowal water levels available from August 1990 to November 2001 indicated levels varied between 202.9 m AHD and 206.2 m AHD over this period. Hawkes (1998) reported that the full storage Lake Cowal water level was 205.65 m AHD. North Limited (1998) reported that the full storage Lake Cowal water level was 205.7 m AHD and the bed level was 201.5 m AHD.

The lake was dry over the years 2005 to 2009. Observations made at Lake Cowal indicate that the lake began to fill with water from June 2011. It has continued to hold water to mid-2014 until drying up in late 2014. It began to fill with water with again with the significant rainfall in mid-2016.

Following filling of Lake Cowal, the water level measurement records show that water level fell at an average rate of between 3 and 4 mm per day over a 12 month period from May 2012. Assuming the lake water is lost to evaporation and considering the annual pan evaporation rate of 1,919 mm, this rate of decline in lake water levels is equivalent to a pan evaporation factor of 0.8 (i.e. an annual open water evaporation rate of 1,535 mm), a factor within the range of expected values for a lake in this regional setting.

When Lake Cowal is full it overflows into Nerang Cowal (North Limited, 1998). Data were not available for historical water levels within Nerang Cowal during wet periods, with the exception that as at August 2010 it was reported by CGO staff that the water within Lake Cowal had not overflowed into Nerang Cowal. Nerang Cowal is likely to have been dry from 2005 until a flood event in March 2012. Satellite imagery shows that Nerang Cowal contained water in mid-2016.

3.15 Groundwater Quality

3.15.1 Groundwater Quality in ML 1535

Electrical Conductivity (EC) concentrations and pH levels in groundwater within ML1535 have generally remained stable between 2004 and 2016. Monitored pH levels have been slightly acidic to neutral, and have been similar to baseline levels. Monitored pH levels near to the TSFs have generally ranged between 6.5 and 7, with the exception of MON01B (to the east of the northern tailings storage facility), with a lower pH generally ranging between 4.5 and 6, and TSFNC with a pH of around 6. While open pit dewatering is causing a localised reduction in groundwater levels, pH and EC appear to be unaffected by this drawdown.

3.15.2 Groundwater Contamination in ML 1535

Cyanide (CN) is used in the gold extraction process and is measured by the CGO as both total cyanide and weak acid dissociable (WAD) cyanide. The ANZECC (2000) trigger value of 0.007 milligrams per litre (mg/L) is for un-ionised hydrogen cyanide (HCN) which may be converted to free cyanide (HCN + CN⁻) using ANZECC Table 8.3.8 from ANZECC (2000) and corresponding pH and temperature values (ANZECC, 2000). The total cyanide is free cyanide plus the measurable cyanide from breakdown of metallo-cyanide and organic complexes.

Monitoring results for cyanide in groundwater were reviewed for the mine life history (September 2004 to June 2016). Within the available data, concentrations over this period have remained below the Limit of Reporting concentration of four micrograms per litre (µg/L) at all monitoring locations, with the exception of those listed in Table 3.

Generally, cyanide has not been observed at significant concentrations in groundwater over the site. Where monitoring has shown total cyanide to be present, its concentration at individual monitoring locations has not been consistent over time, and its observed presence has not always been supported by WAD analysis.

The groundwater monitoring results suggest that, as of June 2016, there is no consistent trend to suggest that significant concentrations of cyanide have leached from the TSF into the surrounding groundwater.

Dissolved arsenic concentrations were less than or close to the laboratory limit of reporting over the 2012 and 2013 years and have not been detected above laboratory reporting levels in 2014 or 2015. Variations in metal concentrations are assessed to reflect the natural heterogeneity in ground conditions, rather than direct impacts from mining, since the regional groundwater system is located in a naturally metalliferous geological terrain.

Table 3. Cyanide Detections

| Year | Month | Bore | Total Cyanide Concentration (mg/L) | WAD Cyanide Concentration (mg/L) |
|--------------|---|---|------------------------------------|----------------------------------|
| 2005 | February | P417B | 0.006 | <0.005 |
| | August | P417B | 0.009 | <0.005 |
| 2006 | August | MON01A | 0.004 | <0.004 |
| 2007 | September | MON01B | 0.084 | 0.041 |
| 2008 | March | P417B | 0.008 | <0.004 |
| | August | PDB3A PDB4A | 0.007 0.109 | 0.006 0.040 |
| 2009 | September | PP01 | 0.030 | 0.03 |
| | | PP05 | 0.072 | 0.04 |
| 2010 | February | MON01B | 0.014 | <0.004 |
| | | P414B | 0.006 | <0.004 |
| | | P417B | 0.007 | <0.004 |
| 2011 | September | PP02 | 0.004 | 0.004 |
| | November | MON01A | 0.045 | 0.004 |
| 2012 | February | TSFNC | 0.017 | <0.004 |
| | March | PP02 | 0.016 | <0.004 |
| | May | P417B | 0.010 | <0.004 |
| | | PP05 | 0.017 | <0.004 |
| | | PP06 | 0.042 | 0.017 |
| | October | TSFNA | 0.009 | <0.004 |
| | | TSFNB | 0.009 | <0.004 |
| TSFNC | | 0.010 | <0.004 | |
| P418A | | 0.015 | <0.004 | |
| P418B | | 0.027 | 0.008 | |
| P558A-R | 0.006 | <0.004 | | |
| P417A | 0.005 | <0.004 | | |
| 2013 | April | MON02A | 0.017 | <0.004 |
| | | P412A-R | 0.027 | <0.004 |
| | | P417A | 0.034 | <0.004 |
| | | P417B | 0.005 | <0.004 |
| 2014 | No detections above laboratory limit of reporting | | | |
| 2015 | September | MON01B | 0.012 | 0.007 |
| | | P414B | 0.017 | 0.01 |
| | | P417B | 0.025 | 0.016 |
| 2016 to June | January | PDB1A, PDB1B, PP01, PP02, PP03, PP04, PP05, PP06, MON01A, MON01B, MON02A, MON02B, P412A, P412A-R, P414A, P414B, P417A, P417B, P418A, P418B, P558A-R, P555A-R, TSFNA, TSFNB, TSFNC | <0.004 | <0.004 |

| Year | Month | Bore | Total Cyanide Concentration (mg/L) | WAD Cyanide Concentration (mg/L) |
|------|-------|---|------------------------------------|----------------------------------|
| | April | PP03, MON01B, MON02A, MON02B, P414A, P414B, P417A, P417B, P558A-R, P555A-R, | <0.004 | <0.004 |
| | | PP01, PP02, PP04, PP05, PP06, MON01A, P412A, P412A-R, P418A, P418B, TSFNA, TSFNB, TSFNC | <0.020 | <0.020 |

3.16 Aquifer Parameters

Coffey (2006) reviewed hydraulic testing data conducted in pumping bores and observation piezometers screened within the Lachlan and Cowra Formations within the Bland Creek Paleochannel Borefield (formerly known as the Jemalong Borefield Area), located to the north-east of the mine site. Transmissivities averaged 35 square metres per day (m^2/day) within the Upper Cowra Formation (up to 50 m depth) and 8 m^2/day within the Lower Cowra Formation (average depth 50 m to 90 m). Interpreted horizontal hydraulic conductivities, converted from transmissivity values using the total screened interval of the borehole, typically ranged from 0.1 to 10 metres per day (m/day).

The adopted parameter values for the calibrated model used in a previous pit dewatering assessment (Coffey, 2008) are shown in Table 4.

Table 4. Adopted Model Parameters (Coffey, 2008)

| Hydrogeological Unit | Geological Unit | Horizontal Hydraulic Conductivity (m/day) | Vertical Hydraulic Conductivity (m/day) | Specific Yield |
|----------------------|----------------------|---|---|----------------|
| Transported | Cowra Formation | 1.0×10^{-3} | 1.0×10^{-4} | 0.15 |
| Saprolite | Lake Cowal Volcanics | 5.0×10^{-2} | 5.0×10^{-2} | 0.02 |
| Saprock | Ordovician Host Rock | 1.0×10^{-2} | 1.0×10^{-2} | 0.02 |
| Primary Rock | Ordovician Host Rock | 1.0×10^{-2} | 1.0×10^{-2} | 0.02 |

Source: Coffey, 2008.

A calibrated groundwater model developed by Coffey (2009a) to assess groundwater level changes at the mine site adopted the parameter values shown in Table 5.

Table 5. Adopted Model Parameters (Coffey, 2009a)

| Hydrogeological Unit | Geological Unit | Horizontal Hydraulic Conductivity (m/day) | Vertical Hydraulic Conductivity (m/day) | Specific Yield |
|----------------------|----------------------|---|---|----------------|
| Transported | Cowra Formation | 1.0×10^{-2} | 3.0×10^{-3} | 0.05 |
| Saprolite | Lake Cowal Volcanics | 1.0×10^{-1} | 1.0×10^{-2} | 0.002 |
| Saprock | Ordovician Host Rock | 1.0×10^{-2} | 1.0×10^{-3} | 0.02 |

Source: Coffey, 2009a.

A recovery test conducted in monitoring bore PD3 (see Figure 12 for bore location), screened over the Transported and Saprolite units, suggested those units possessed a collective transmissivity of 1.2 m²/d (Coffey, 2008). In consideration of the 90.5 m total screen interval of PD3, the estimated horizontal hydraulic conductivities over both the Transported and Saprolite units were estimated at 0.01 m/day.

Coffey (2009a) collated falling head permeability test data from piezometers located both within and to the east of the TSF area. Results suggested the following hydraulic conductivity values:

- an arithmetic mean of 0.02 m/day and a geometric mean of 0.01 m/day for the Transported at 6 to 16 m below ground surface; and
- an arithmetic mean of 0.05 m/day and a geometric mean of 0.02 m/day for the Saprolite at 18 to 36 m below ground surface.

These values are relatively consistent with the PD3 recovery test result noted above and the values adopted in the calibrated pit dewatering assessment model (Coffey, 2008), as shown in Table 5.

No hydraulic test data were available from which an assessment of the specific yield of the Cowra Formation could be made. Numerical modelling conducted by Williams (1993) assumed a value of 5% for the pore volume available for increased storage at the water table in the Upper Cowra Formation in the Jemalong Plains Irrigation District. Based on lithology and literature (Johnson, 1967) a specific yield of 4% was adopted for groundwater supply modelling (Coffey, 2006).

Coffey analysed results from pumping tests undertaken in the dewatering bores in 2004. Bores were screened over the full sequence of Transported, Saprolite and Saprock units. This introduces some uncertainty as flow components attributable to individual aquifer horizons are unknown. The horizons are somewhat gradational and precise boundaries are difficult to identify. The average hydraulic conductivity from the analysed data was 0.06 m/day.

Based on pumping test, recovery test and slug test data (Coffey, 1995a), Hawkes (1998) adopted the model parameters shown in Table 6 for a pit dewatering model. It should be noted that the model developed by Hawkes (1998) considered alternating aquifer and aquitard model layers throughout (i.e. contrastingly high and low hydraulic conductivity units alternated with depth), and divided the Transported unit into two aquifers (relatively high hydraulic conductivity units) and two aquitards (relatively low hydraulic conductivity units). Data were sufficient for this approach in modelling the pit area alone.

A calibrated groundwater model developed by NOW (now DPI Water) (unknown publication date) for the Upper Lachlan catchment adopted horizontal hydraulic conductivities generally range from one to 20 m/day in the Lower Cowra Formation and from one to 35 m/day in the Upper Cowra Formation over the present model domain.

Table 6. Adopted Model Parameters (Hawkes, 1998)

| Hydrogeological Unit | Geological Unit | Horizontal Hydraulic Conductivity (m/day) | Vertical Hydraulic Conductivity (m/day) | Specific Yield | Confined Storage Coefficient |
|----------------------|----------------------|---|---|----------------------|------------------------------|
| Transported | Cowra Formation | 2.0×10^0 to 3.0×10^0 | 1.0×10^{-4} | 1.0×10^{-3} | 1.5×10^{-1} |
| Saprolite | Lake Cowal Volcanics | - | 1.0×10^{-4} | - | - |
| Saprock | Ordovician Host Rock | 1.5×10^0 | - | 1.0×10^{-2} | 1.0×10^{-3} |
| Primary Rock | Ordovician Host Rock | - | 1.0×10^{-4} | - | - |

Source: Hawkes, 1998.

Analysis of pumping tests conducted in 2004 in bores of the Bland Creek Paleochannel Borefields, located to the north-east of the mine site area, provide several values of confined storativity, giving an average storativity of 1.9×10^{-4} for the Lachlan Formation (Groundwater Consulting Services Pty Ltd [GCS], 2006), or an average specific storage of $9.5 \times 10^{-6} \text{ m}^{-1}$, assuming a 20 m thick aquifer. A pumping test of seven days duration conducted at BLPR2 (located approximately 18 km to the north-north east of pit E42) gave an average storativity of 1.7×10^{-4} for the Lachlan Formation, or an average specific storage of $8.5 \times 10^{-6} \text{ m}^{-1}$, assuming a 20 m thick aquifer. The lower permeability sediments that occur further away from the deeper parts of the palaeochannel appear to possess similar hydraulic properties to the Lower Cowra Formation (Coffey, 2006). However, in practical terms, a portion of the assessed storativities will be influenced by vertical leakage from the base of the Lower Cowra Formation during pumping tests.

A calibrated groundwater model developed by NOW (now DPI Water) (unknown publication date) for the Upper Lachlan catchment adopted specific yield values generally ranging from 0.06 to 0.3 in the Upper Cowra Formation. Storage coefficients in the same model generally ranged from 5.5×10^{-6} to 1.7×10^{-5} in the Lower Cowra Formation.

GCS (2008) co-ordinated a pumping test in the Transported materials (Cowra Formation). The testing was conducted to assess the potential yield of the Saline Supply Borefield, located within the ML 1535. Test results suggest a hydraulic conductivity of the Transported material of approximately 5 m/d and a specific yield of approximately 1.6×10^{-3} .

A summary of the available data is presented in Tables 7 and 8.

Table 7. Summary of Horizontal Hydraulic Conductivity Data

| Hydrogeological Unit (Geological Unit) | Value (m/day) | Region | Source | Reference |
|---|---------------------------------------|--|-----------------------|----------------|
| Transported (Cowra Formation) | 1×10^{-1} to 1×10^2 | Jemalong Borefield | Hydraulic testing | Coffey (2006) |
| | 5×10^0 | Saline Supply Borefield, ML 1535 | Pumping test | GCS (2008) |
| | 1×10^{-2} | TSF | Slug test | Coffey (2009a) |
| | 1×10^{-2} | Mine Site | Modelling | Coffey (2009a) |
| | 1×10^{-3} | E42 open Pit | Modelling | Coffey (2008) |
| | 2×10^0 to 3×10^0 | E42 open Pit | Modelling | Hawkes (1998) |
| | 1×10^0 to 3.5×10^1 | Upper Lachlan catchment | Modelling | NOW (unknown) |
| | 1 to 2 | Jemalong | Regional Modelling | Coffey (2011) |
| | 1 | Elsewhere | | |
| Transported (Cowra Formation) and Saprolite | 1×10^{-2} | E42 open Pit | Recovery test | Coffey (2008) |
| Transported (Cowra Formation), Saprolite and Saprock (Ordovician Host Rock) | 6×10^{-2} | E42 open Pit | Pumping test | Coffey (1995a) |

Table 7 (Continued). Summary of Horizontal Hydraulic Conductivity Data

| Hydrogeological Unit (Geological Unit) | Value (m/day) | Region | Source | Reference |
|---|---------------------------------------|-----------------------|-----------------------|----------------|
| Saprolite | 2×10^{-2} | TSF | Slug testing | Coffey (2009a) |
| | 1×10^{-1} | Mine Site | Modelling | Coffey (2009a) |
| | 5×10^{-2} | E42 open Pit | Modelling | Coffey (2008) |
| Saprock (Ordovician Host Rock) | 1×10^{-2} | Mine Site | Modelling | Coffey (2009a) |
| | 1×10^{-2} | E42 open Pit | Modelling | Coffey (2008) |
| | 1.5×10^0 | E42 open Pit | Modelling | Hawkes (1998) |
| Primary Rock (Ordovician Host Rock) | 1×10^{-2} | E42 open Pit | Modelling | Coffey (2008) |
| Lachlan Formation | 3×10^{-2} to 1×10^2 | Jemalong Borefield | Hydraulic testing | Coffey (2006) |
| | 3 to 28 | Regionally | Regional Modelling | Coffey (2011) |

Table 8. Summary of Specific Yield and Storage Data

| Unit(s) | Specific Yield | Storage Coefficient | Region | Source | Reference |
|-----------------------------------|---|---|---|-----------------------|------------------|
| Transported (Cowra Formation) | 1.0×10^{-3} | 1.5×10^{-1} | E42 open Pit | See text | Hawkes (1998) |
| | 1.5×10^{-1} | - | E42 open Pit | Modelling | Coffey (2008) |
| | 5.0×10^{-2} | - | Mine Site | Modelling | Coffey (2009a) |
| | 6.0×10^{-2} to 3.0×10^{-1} | 5.5×10^{-6} to 1.7×10^{-5} | Upper Lachlan catchment | Modelling | NOW (unknown) |
| | 1.6×10^{-3} | - | Saline Supply Borefield, Mine Lease | Pumping test | GCS (2008) |
| | 4.0×10^{-2} | 1.5×10^{-5} | Regionally | Regional Modelling | Coffey (2011) |
| Saprolite | 2.0×10^{-2} | - | E42 open Pit | Modelling | Coffey (2008) |
| | 2.0×10^{-3} | - | Mine Site | Modelling | Coffey (2009a) |
| Saprock (Ordovician Host Rock) | 1.0×10^{-2} | 1.0×10^{-3} | E42 open Pit | See text | Hawkes (1998) |
| | 2.0×10^{-2} | - | E42 open Pit | Modelling | Coffey (2008) |
| | 2.0×10^{-2} | - | Mine Site | Modelling | Coffey (2009a) |

Table 8 (Continued). Summary of Specific Yield and Storage Data

| Unit(s) | Specific Yield | Storage Coefficient | Region | Source | Reference |
|--|----------------------|----------------------|--------------------|--------------------|----------------|
| Primary Rock (Ordovician Host Rock) | 2.0×10^{-2} | - | E42 open Pit | Modelling | Coffey (2008) |
| Lachlan Formation | 1.9×10^{-4} | - | Jemalong Borefield | Pumping test | GCS (2006) |
| | 1.7×10^{-4} | - | Jemalong Borefield | Pumping test | Coffey (1995c) |
| | N/A | 1.5×10^{-5} | Regionally | Regional Modelling | Coffey (2011) |

The bedrock has relatively low hydraulic conductivity (Table 7). Coffey (1995a) noted that there was little apparent difference in transmissivity between the major structural features (fractured dykes) within the pit area and relatively fresh bedrock. Therefore, aquifer parameters are expected to be similar for bedrock and geological fault features. The bedrock consists mostly of sedimentary sequences and is considered to have significantly lower permeability than unconsolidated sediments, except in structurally disturbed areas.

3.16.1 Tailings Storage Facilities

Based on test drilling data, geophysical studies and piezometer installations around the proposed TSF reported by North Limited (1998):

- The foundation of the TSF comprises silty clay with some gravelly clay, and highly weathered rock occurring at shallow depth in the west. The thickness of unconsolidated sediments decreases from east to west.
- The groundwater movement through the tailings areas prior to mine development was essentially from west to east with a hydraulic gradient of about 7×10^{-3} m.
- Field permeability testing of strata expected to be of higher permeability indicate low horizontal permeability of the order of 2×10^{-4} to 1×10^{-3} m/day for gravelly clay and 0.6×10^{-4} to 3.5×10^{-4} m/day for weathered rock.
- Laboratory infiltration tests indicate vertical permeability of the less permeable soils of the order of 0.9×10^{-6} to 1.3×10^{-6} m/day.

URS Australia Pty Limited (URS) (2005, 2006) conducted field investigations and laboratory testing for both the northern and southern tailings storage facility, concluding that:

- Investigations consistently showed the uppermost 5 m of the TSF footprints to be essentially clay soils of extremely low permeability.
- Laboratory testing of typical samples from within 5 m of floor level yielded permeabilities less than the target permeability of 1×10^{-9} metres per second (m/s) (9×10^{-5} m/day).
- Inspections of cut-off trench excavation and storage floor did not reveal any significant extensive or continuous zones or lenses of high permeability soil that might provide a leakage path.

Surface infiltration tests carried out by site personnel in shallow test pits to the east of the TSF area (Coffey, 1995b) indicated a low infiltration permeability range from 8×10^{-4} m/day to 3×10^{-5} m/day, with an arithmetic mean of 2×10^{-4} m/day and a geometric mean of 1×10^{-4} m/day.

Falling head permeability tests and consolidation tests were conducted by Knight Piesold Pty Ltd (1994) on saturated tailings samples with unrestricted drainage from the base. Results are shown in Table 9 and indicate the permeability of saturated tailings (prior to additional consolidation due to tailings loading or air drying).

Table 9. Tailings Permeability Data (Knight Piesold Pty Ltd, 1994)

| Test Type | Sample | Permeability (m/day) | Dry Density (t/m ³) |
|---------------------------------|------------------|----------------------|---------------------------------|
| Falling Head Permeability Tests | Primary Tailings | 0.02 | 1.29 |
| | | 0.02 | 1.29 |
| | Oxide Tailings | 0.01 | 1.18 |
| | | 0.01 | 1.20 |
| Consolidation Tests | Primary Tailings | 0.62 | 1.07 |
| | | 0.09 | 1.10 |
| | | 0.02 | 1.20 |
| | Oxide Tailings | 0.27 | 0.95 |
| | | 0.03 | 0.99 |
| | | 0.01 | 1.12 |
| | | 0.01 | 1.13 |

Source: Knight Piesold Pty Ltd, 1994.

t/m³ – tonnes per cubic metre.

A calibrated groundwater model developed by Coffey (2009a) to assess groundwater level changes associated with the TSFs adopted the parameter values shown in Table 10 for tailings materials.

Table 10. Adopted Model Parameters (Coffey, 2009a)

| Unit | Horizontal Permeability (m/day) | Vertical Permeability (m/day) | Specific Yield |
|-----------------------|---------------------------------|-------------------------------|----------------|
| Deposited Tailings | 5.0×10^{-2} | 5.0×10^{-3} | 0.01 |
| TSF Embankment - Clay | 1.0×10^{-4} | 1.0×10^{-4} | 0.15 |
| TSF Embankment - Fill | 5.0×10^0 | 5.0×10^0 | 0.15 |

Source: Coffey, 2009a.

A summary of the above information is presented in Table 11.

Table 11. Summary of TSF Parameters

| Hydrogeological Unit | Horizontal Permeability (m/day) | Vertical Permeability (m/day) | Specific Yield | Reference |
|-----------------------|--|--|----------------|------------------------|
| TSF Foundation | 1×10^{-3} to 6×10^{-5} | 1.3×10^{-6} to 9×10^{-7} | N/A | North Limited (1998) |
| | N/A | 8.6×10^{-5} | N/A | URS (2005, 2006) |
| | N/A | 2×10^{-4} | N/A | Coffey (1995b) |
| Deposited Tailings | N/A | 1×10^{-2} to 6.2×10^{-1} | N/A | Knight Piesold (1994) |
| | 5.0×10^{-2} | 5.0×10^{-3} | 0.01 | Coffey (2009a) (model) |
| TSF Embankment - Clay | 1.0×10^{-4} | 1.0×10^{-4} | 0.15 | Coffey (2009a) (model) |
| TSF Embankment - Fill | 5.0×10^0 | 5.0×10^0 | 0.15 | Coffey (2009a) (model) |

3.17 Representation of Mining Activities

3.17.1 Mine Production

The indicative mine production schedule for the Modification, provided by Evolution, is shown in Table 12.

Table 12. Indicative Mine Production Schedule.

| MOD13 | Year | CGO Year | Waste Rock Mined | Min Waste Mined (Mt ¹) | | | Ore Mined (Mt ¹) | | | Ore Processed (Mt ¹) | | |
|------------------------------------|--------------|----------|--------------------|------------------------------------|--------------|--------------|------------------------------|---------------|---------------|----------------------------------|---------------|---------------|
| | | | (Mt ¹) | Oxide | Primary | Total | Oxide | Primary | Total | Oxide | Primary | Total |
| Existing CGO | 2005 to 2015 | 1 to 11 | 209.26 | 5.04 | 10.94 | 15.98 | 16.5 | 73.75 | 90.25 | 5.83 | 62.01 | 67.83 |
| CGO Incorporating the Modification | 2016 | 12 | 2.38 | 0 | 1.26 | 1.26 | 0 | 8.7 | 8.7 | 0 | 7.17 | 7.17 |
| | 2017 | 13 | 12.57 | 0 | 1.05 | 1.05 | 0 | 9.43 | 9.43 | 0 | 7.5 | 7.5 |
| | 2018 | 14 | 22.14 | 0.15 | 0.96 | 1.11 | 0.07 | 9.14 | 9.21 | 0 | 7.36 | 7.36 |
| | 2019 | 15 | 23.48 | 0.01 | 1.2 | 1.21 | 0 | 5.5 | 5.5 | 0 | 7.3 | 7.3 |
| | 2020 | 16 | 21.49 | 0 | 1.44 | 1.44 | 0 | 2.39 | 2.39 | 3.82 | 3.68 | 7.5 |
| | 2021 | 17 | 10.76 | 0 | 4.51 | 4.51 | 0 | 10.48 | 10.48 | 0 | 7.46 | 7.46 |
| | 2022 | 18 | 4.11 | 0 | 2.65 | 2.65 | 0 | 11.85 | 11.85 | 0 | 7.36 | 7.36 |
| | 2023 | 19 | 2.08 | 0 | 1.59 | 1.59 | 0 | 8.42 | 8.42 | 0 | 7.33 | 7.33 |
| | 2024 | 20 | 0.8 | 0 | 0.13 | 0.13 | 0 | 1.91 | 1.91 | 0 | 7.47 | 7.47 |
| | 2025 | 21 | 0 | 0 | 0 | 0 | 0 | 0 | 0 | 0 | 7.5 | 7.5 |
| | 2026 | 22 | 0 | 0 | 0 | 0 | 0 | 0 | 0 | 0 | 7.5 | 7.5 |
| | 2027 | 23 | 0 | 0 | 0 | 0 | 0 | 0 | 0 | 0 | 7.5 | 7.5 |
| | 2028 | 24 | 0 | 0 | 0 | 0 | 0 | 0 | 0 | 0 | 7.5 | 7.5 |
| | 2029 | 25 | 0 | 0 | 0 | 0 | 0 | 0 | 0 | 0 | 7.5 | 7.5 |
| | 2030 | 26 | 0 | 0 | 0 | 0 | 0 | 0 | 0 | 2.33 | 5.17 | 7.5 |
| | 2031 | 27 | 0 | 0 | 0 | 0 | 0 | 0 | 0 | 7.5 | 0 | 7.5 |
| | 2032 | 28 | 0 | 0 | 0 | 0 | 0 | 0 | 0 | 2.29 | 0 | 2.29 |
| | Sub-Total | | | 99.81 | 0.16 | 14.79 | 14.95 | 0.07 | 67.82 | 67.89 | 15.94 | 105.3 |
| Total | | | 309.07 | 5.12 | 25.73 | 30.93 | 16.57 | 141.57 | 158.14 | 21.77 | 167.31 | 189.07 |

¹Mt – Million tonnes

3.17.2 Excavation Schedule

Open pit geometries were provided at intervals from December 2005 to June 2010, as well as for December 2011 and December 2012. The proposed pit geometry for 2015 and planned geometry from 2018 to 2032 (mine closure) were provided by Evolution.

Based on these data, Figure 13 shows the base elevation of the open pit at mine closure.

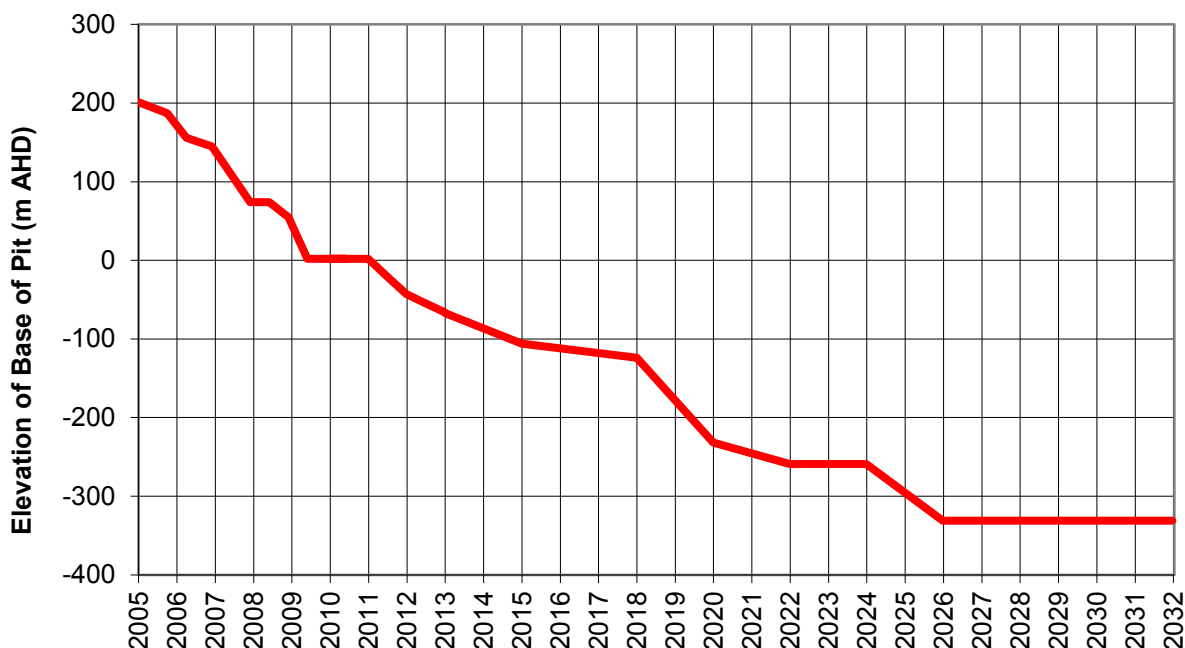

Figure 13 – Elevation of Base of Open Pit.

3.17.3 Open Pit Dewatering

A ring of vertical dewatering bores, comprising bores PD1 to PD28, PD30 and PD22, have historically operated to control groundwater levels around the pit. The vertical bore dewatering system was commissioned progressively, commencing in January 2005 to full operation by mid-2005. Records of dewatering volumes for the vertical bores for the period February 2005 to December 2009 indicate relatively consistent results after August 2005.

By 2012, all of the initial sets of bores had been decommissioned. Seven new dewatering bores (PD101 to PD107) were installed during 2011 as part of the Stage E pit cutback and began pumping groundwater in November 2011 (see Figure 12 for locations of both active and decommissioned bores).

In addition to the vertical dewatering bores, horizontal bores (drains) have been progressively installed (and some decommissioned) within the open pit since 2006.

Groundwater seepage from the pit, groundwater flows from in-pit horizontal drains (bores), and rainfall runoff in the pit are directed to pit sumps (before being pumped to water storage dams).

Mine records the volumes pumped out of in-pit sumps (daily) and the volumes abstracted by the vertical dewatering bores on a monthly basis. The volume pumped out of in-pit sumps in any month is the sum of the volumes from the rainfall runoff, pit face seepage, and horizontal bores (drains). As such, it is not clear what proportion of the volumes reporting to the in-pit sumps is rainfall runoff rather than pit seepage/drainage. Mine staff report that rainfall runoff within the pit is generally significant for daily rainfall over 30 mm.

Figure 14 shows the measured dewatering flow rate (sumps and vertical bores) over the mine life, as well as daily rainfall events over 30 mm. There is a correlation between daily rainfall events over 30 mm and relatively high sump flows between 2010 and 2012. In 2005, 2006 and 2007, this correlation does not appear to be present. However, this may be due to relatively dry pre-existing ground conditions (in 2004, and from 2006 to 2009, the annual rainfall was significantly below the mean annual rainfall, potentially resulting in dry conditions relative to 2010 and 2012, and reduced rainfall runoff for rainfall events over 30 mm).

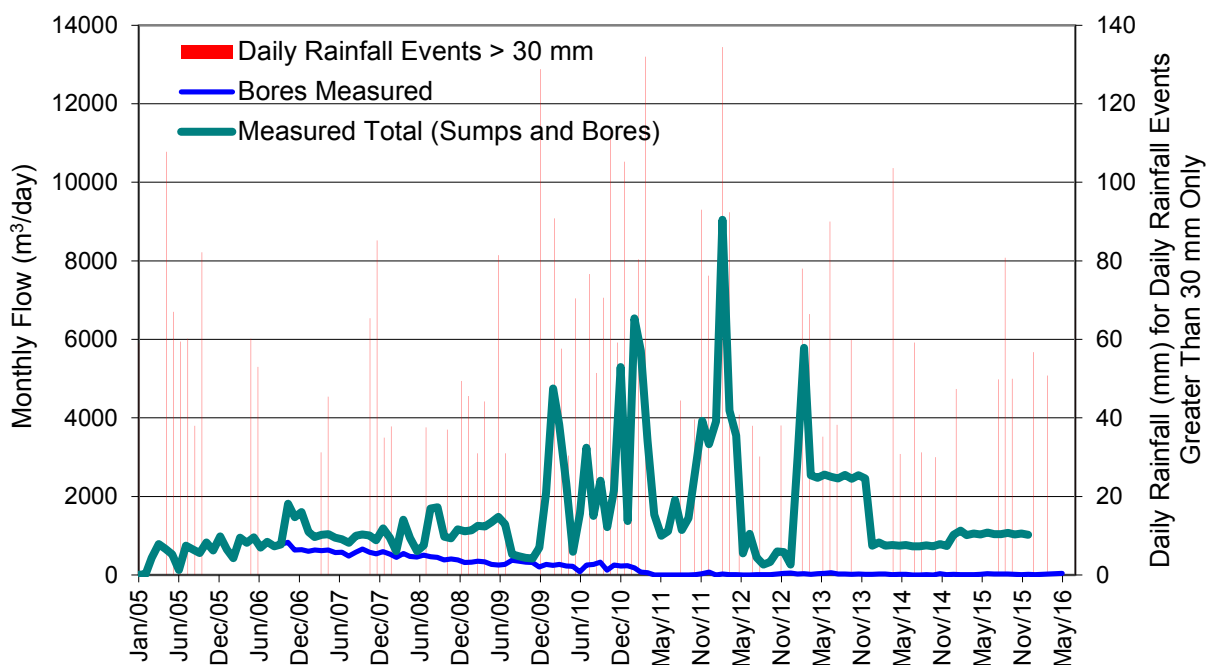

Figure 14 – Pit Dewatering Rates and Rainfall.

Groundwater inflows to the pit due to pit seepage and horizontal dewatering bores (drains) between 2010 and 2016 were estimated, considering significant rainfall events and horizontal dewatering bore installation frequency. The interpreted inflows (for pit face seepage and horizontal dewatering bores only, excluding rainfall runoff) are shown in Figure 15. As of mid-2016, it is estimated that groundwater inflows are at approximately 400 m³/day (i.e. approximately 146 megalitres per annum [ML/annum]), with approximately 90% of inflows from the Fractured Rock groundwater system and 10% of inflows from the Alluvial groundwater system. A letter from Department of Primary Industries – Office of Water to CGO (then owners Barrick), titled “Cowal Gold Mine – Request for reallocation of water access licence under the water management act 2000” and dated 7 January 2014; addresses the renewal of water access licences based on these requirements. The interpreted flows were adopted as the measured values against which the model was calibrated.

In conclusion, groundwater inflow to the open pit is estimated to have generally decreased since 2008 as the adjacent acquirers surrounding the CGO open pit have become depressurised. No material increase in groundwater inflow to the open pit is estimated to have occurred during and following the 2010 and 2012 lake-fill events based on monitored pit dewatering records.

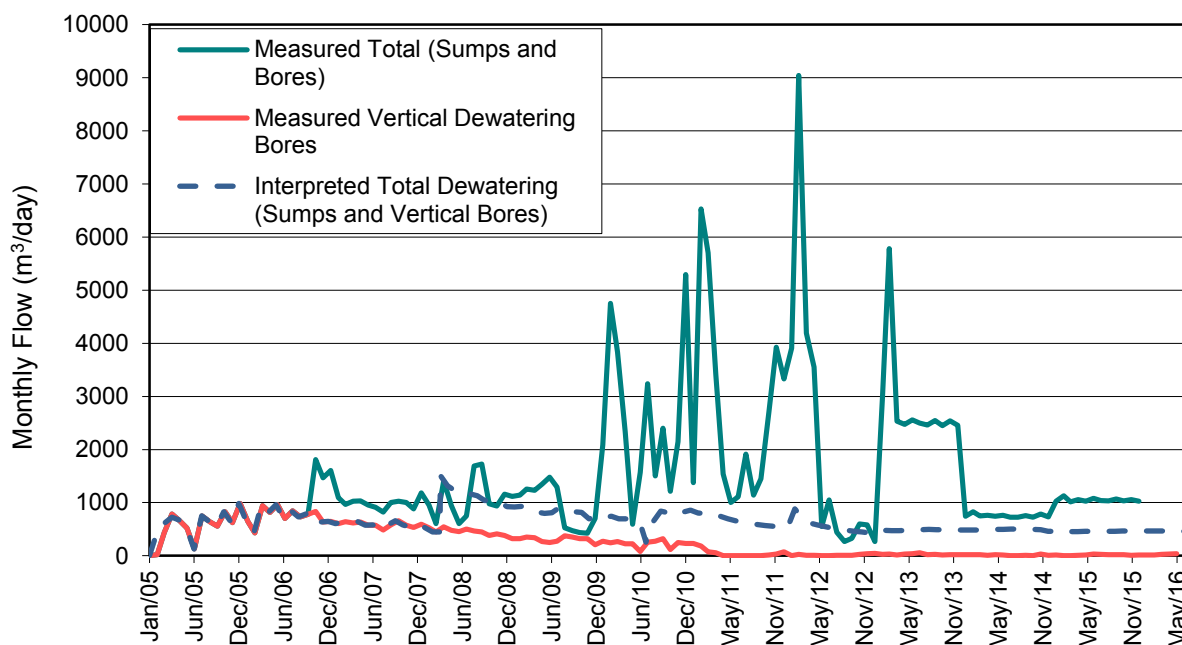

Figure 15 – Interpreted Pit Dewatering Rates.

3.17.4 Storage Dams

Storage dams located on the mine site are shown in Figure 11.

Historical water levels within the storage dams D1, D2, D3, D4, D5, D6, D8B and D9 were reviewed. Dams D1, D2, D4, D5, D6 and D8B were small and located such that their impact on groundwater levels is likely to be insignificant.

Available groundwater monitoring data (PP06, screened within the Transported unit, as shown in Figure A-5) suggest that water seepage from dam D9 does not impact groundwater levels. Early transient model calibration simulations supported this assessment and the dam D9 was not included within the model thereafter.

3.17.5 Tailings Storage Facilities

Tailings are understood to have been released to:

- the southern tailings storage facility from 20 April 2006 to 15 May 2007;
- the northern tailings storage facility 15 May 2007 to 12 September 2008;
- the southern tailings storage facility from 12 September 2008 to 8 December 2009;
- the northern tailings storage facility from 8 December 2009 to 16 January 2011;

- the southern tailings storage facility from 16 January 2011 to 9 March 2012;
- the northern tailings storage facility from 9 March 2012 to 14 June 2013;
- the southern tailings storage facility from 14 June 2013 to 1 September 2014;
- the northern tailings storage facility from 1 September 2014 to 2 November 2015;
- the southern tailings storage facility from 2 November 2015 onwards.

Crest levels provided by Evolution are shown in Table 13.

Due to tailings solids deposition, the surface of deposited tailings rises over time within each TSF dam. The lowest elevation of the surface of deposited tailings within each TSF dam was estimated based on the nominated crest levels, known TSF dam geometries, and assuming a tailings beach slope of 0.5%. Table 13 presents the estimated lowest deposited tailings surface elevation within each TSF dam.

Historical tailings dam water levels were not available. However, historical percentage water coverage data for the tailings dams were provided from May 2006 to September 2010, and for March 2012 to November 2012. Based on the geometry of the tailings dams, the maximum water depth within both the northern and southern tailings storage facility averaged over these periods is estimated to be 0.2 m.

The average surface water elevation within each of the TSF is estimated to be the lowest deposited tailings surface point plus 0.2 m (i.e. 0.2 m of standing water lie above the deposited tailings in each dam at any time). The estimated average water elevations are shown in Figure 16.

Since the hydraulic conductivity of the TSF foundation material is lower than that of the deposited tailings (Table 11), the surface water lying within the storage facility ponds is expected to maintain full hydraulic connection with the top of the TSF foundation material (through the deposited tailings).

Table 13. Tailings Dam Crest Levels and Low Points

| Status Start Date | Northern Tailings Storage Facility | | | Southern Tailings Storage Facility | | |
|-------------------|------------------------------------|---------------------|-------------------|------------------------------------|---------------------|-------------------|
| | Operation Status | Crest Level (m AHD) | Low Point (m AHD) | Operation Status | Crest Level (m AHD) | Low Point (m AHD) |
| 20-Apr-06 | Inactive | - | - | Active | 225.6 | 222.4 |
| 15-May-07 | Active | 222.0 | 218.8 | Inactive | 225.6 | 222.4 |
| 12-Sep-08 | Inactive | 222.0 | 218.8 | Active | 229 | 225.8 |
| 8-Dec-09 | Active | 225.0 | 221.8 | Inactive | 229 | 225.8 |
| 16-Jan-11 | Inactive | 225.0 | 221.8 | Active | 232.2 | 229.1 |
| 9-Mar-12 | Active | 228.2 | 225.1 | Inactive | 232.2 | 229.1 |
| 14-Jun-13 | Inactive | 228.2 | 225.1 | Active | 235.4 | 232.4 |
| 1-Sep-14 | Active | 231.7 | 228.7 | Inactive | 235.4 | 232.4 |
| 2-Nov-15 | Inactive | 231.7 | 228.7 | Active | 239.0 | 236.1 |
| 1-Dec-16 | Active | 236.0 | 233.1 | Inactive | 239.0 | 236.1 |

Table 13 (Continued). Tailings Dam Crest Levels and Low Points

| Status Start Date | Northern Tailings Storage Facility | | | Southern Tailings Storage Facility | | |
|-------------------|------------------------------------|---------------------|-------------------|------------------------------------|---------------------|-------------------|
| | Operation Status | Crest Level (m AHD) | Low Point (m AHD) | Operation Status | Crest Level (m AHD) | Low Point (m AHD) |
| 1-Mar-18 | Inactive | 236.0 | 233.1 | Active | 243.7 | 240.9 |
| 1-May-19 | Active | 240.5 | 237.7 | Inactive | 243.7 | 240.9 |
| 1-Jul-20 | Inactive | 240.5 | 237.7 | Active | 248.4 | 245.7 |
| 1-Aug-21 | Active | 244.7 | 242.0 | Inactive | 248.4 | 245.7 |
| 1-Apr-23 | Inactive | 244.7 | 242.0 | Active | 253.1 | 250.5 |
| 1-May-24 | Active | 248.9 | 246.8 | Inactive | 253.1 | 250.5 |
| 1-Sep-25 | Inactive | 248.9 | 246.8 | Active | 257.8 | 255.3 |
| 1-Aug-26 | Active | 253.1 | 251.6 | Inactive | 257.8 | 255.3 |
| 1-Nov-27 | Inactive | 253.1 | 251.6 | Active | 262.5 | 260.1 |
| 1-Oct-28 | Active | 258.8 | 256.4 | Inactive | 262.5 | 260.1 |
| 1-Jan-30 | Inactive | 258.8 | 256.4 | Active | 267.2 | 264.9 |
| 1-Oct-30 | Active | 263.5 | 261.2 | Inactive | 267.2 | 264.9 |
| 1-Dec-31 | Inactive | 263.5 | 261.2 | Active | 271.9 | 269.7 |
| 3-Jun-32 | Inactive | 263.5 | 261.2 | Inactive | 271.9 | 269.7 |

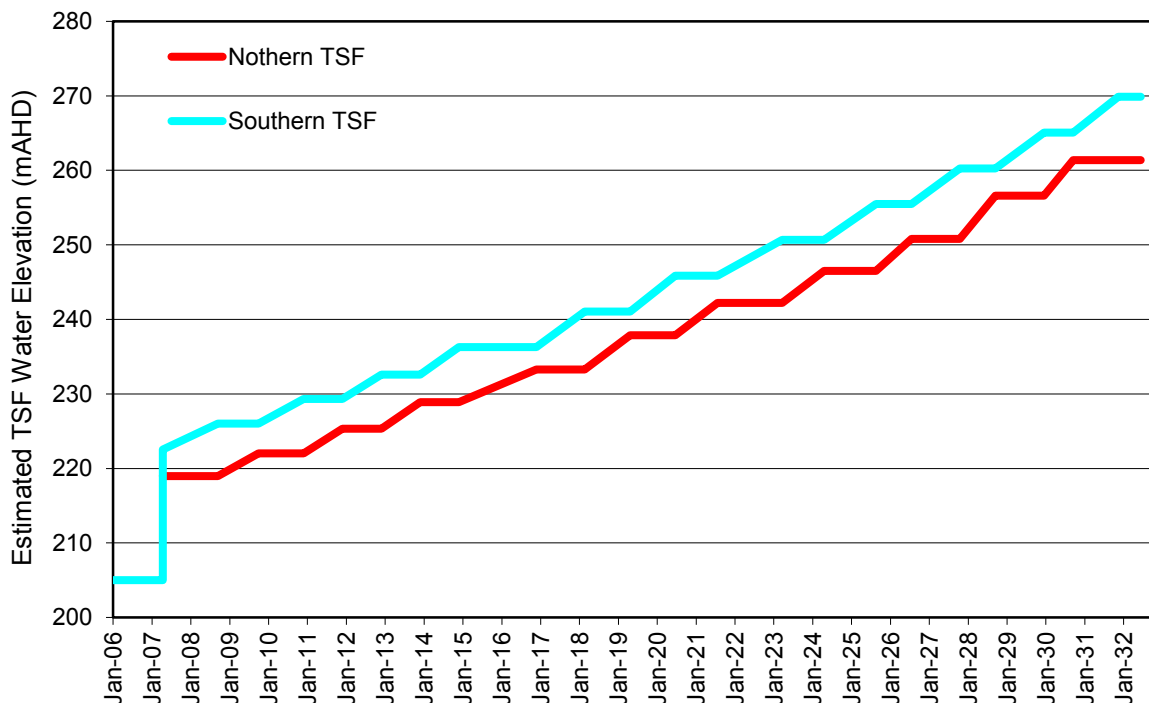

Figure 16 – Tailing Storage Facility Water Levels.

4 HYDROGEOLOGICAL MODELLING

A model of the groundwater system in the vicinity of the mine was established comprising multiple layers over the pit area and the surrounding areas. This model was used to assess potential impacts from the operation of ML 1535 saline groundwater supply borefield, the potential for hydraulic connection between Lake Cowal and the mine site groundwater system, groundwater inflows to the open pit, the effects of seepage from the TSFs and the short and long-term effects of mine closure on ground water conditions.

4.1 Conceptual Model

4.1.1 Model Domain

The domain covered by the Mine Site Model is shown in Figure A-7, which also shows the model domains considered in previous Coffey models (Coffey, 1995d, 2006, 2009a and 2009b). The model covers the area from MGA E530000 to E545000 and MGA N62650000 to N62880000.

The model domain adopted for groundwater flow modelling is bounded in the west by a high ridge (Cowal West Hill), which is approximately 3 km west of the Gilmore Suture, and in the east by the Bland Creek Palaeochannel. Cowal West Hill in the west separates surface flow (recharge) between an easterly and westerly direction. The Cowal West Hill feature is therefore adopted as the western boundary, over which a constant (with respect to time) groundwater head is likely. The constant (with respect to time) value may vary from north to south.

The Bland Creek Palaeochannel contains a deep alluvial layer which is much more transmissive than the upper regional alluvial aquifer system. Since groundwater heads are likely to be relatively stable in this region, this has been selected as the eastern boundary of the model domain. Groundwater heads within the shallow sediments (Transported unit) beneath Lake Cowal are expected to be similar to the lake surface water head values. Coffey (2006) data for December 1997 suggest the groundwater head along the eastern model boundary outside of Lake Cowal, and within deep strata below the lake, is likely to be approximately 200 m AHD. Similarly, NOW (unknown publication date) model considered a groundwater head within the Upper Cowra Formation of approximately 200 m AHD in this area. Data (Coffey, 2006) suggest groundwater head values at the eastern boundary decline running south to north.

Assessment of groundwater levels at the Nerang Cowal and Marsden sections (Coffey, 1995b) suggested groundwater levels at these locations would not be affected by mine dewatering. Net flow into/out of the domain over the western portion of the northern model domain boundary (western end of Nerang Cowal section) is expected to be negligible. Data were not available for water levels within Nerang Cowal. However, groundwater levels within shallow sediments (Transported unit) beneath Nerang Cowal at the northern model boundary are expected to follow a similar trend to those beneath Lake Cowal, and the levels beneath Nerang Cowal are expected to be slightly lower in value than those beneath Lake Cowal (when the lakes are inundated). This results in groundwater flow in a direction from Lake Cowal towards Nerang Cowal, as confirmed by the historical data shown in Figures A-8 to A-15, and reported in Coffey (2006).

At the southern model boundary, data (Coffey, 2006) suggest net groundwater flow into or out of the domain is zero.

Groundwater modelling by NOW (unknown publication date) adopted initial (pre-mining) groundwater head values in the vicinity of ML 1535 and Lake Cowal approximately ranging from 200 to 230 m AHD (heads falling in an easterly direction) in the Upper Cowra Formation and values of 230 m AHD in the Lower Cowra Formation. For the Transported hydrogeological unit in the present conceptual model, this is likely to equate to initial (pre-mining) groundwater head values of approximately 200 to 230 m AHD. The eastern values are similar to those reported for April 1996 by Hawkes (1998).

4.1.2 Hydrogeological Units

In terms of the site mining activities and site geological investigation (Coffey, 1995c; North Limited, 1998), the following seven hydrogeological units have been identified for the purposes of modelling (Mine Site Model):

- **Transported unit:** Comprises alluvial deposits of relatively low hydraulic conductivity clays and to a gravel aquifer within the alluvium which includes Gilgai, Czir, Qa, Qr and Qal sediments (see Figure 7). The waste rock emplacement is represented by this unit, though it generally possesses higher permeability than other alluvial deposits. The recharge from the waste rock emplacements is not considered to significantly impact groundwater movement. This unit becomes the Upper Cowra Formation further east.
- **Saprolite unit:** Comprises a soft oxide material (extremely weathered mudstone, sandstone or diorite). This unit lies directly above the base of the Cowra Formation alluvium and forms a more permeable zone throughout the mine site, extending beneath Lake Cowal with unknown thickness.
- **Saprock unit:** Comprises a hard oxide material (weathered mudstone, sandstone or diorite) of relatively low hydraulic conductivity lying above the weathered fractured surface of the Lake Cowal Volcanics. This unit has relatively high clay content and limited water carrying capacity. The Saprolite and Saprock units are considered equivalent to the Lower Cowra Formation.
- **Lachlan Formation unit:** Comprises high permeability sands and minor gravels close to and within the deeper parts of the Bland Creek Palaeochannel and lower permeability sediments that generally occur further away from the deeper parts of the palaeochannel and surround the high permeability sands and minor gravels. It features over a small area in the far western portion of the modelled domain.
- **Primary Rock (Bedrock) unit:** Mainly consists of volcanoclastic rocks of low permeability.

The TSF are represented by the following distinct hydrogeological units:

- **Tailings Storage Facilities unit:** The TSF comprise about 55% solids, with finely ground rock residue remaining after the flotation and leaching process. The consolidated residue was found to be of low permeability.

- **Tailings Storage Facilities Embankment unit:** A basal barrier and impermeable liner with an equivalent vertical permeability not greater than 1×10^{-9} m/s (9×10^{-5} m/day) over a thickness of 2 m was present at the base of tailings dams (A letter from URS to the Cowal Gold Project of 20 January 2006 reviewed conditions at the base of the southern tailings storage facility taking account of extensive test pitting, trenching and drilling investigations. It concluded that testing had shown the permeability to be typically an order of magnitude low than the specification of 1×10^{-9} m/s over the uppermost 5 m of the site. Coffey note that removal of borrow material for up to a thickness of 3 m, as nominated in the letter, would leave at least 2 m of low permeability clay at the base of the facility). Coffey anticipate similar conditions would have prevailed in the northern tailings storage facility).

4.1.3 Groundwater Recharge

Groundwater recharge sources over the Mine Site Model domain include rainfall and surface water bodies (contained water storages and Lake Cowal). These are discussed in Section 4.3.1.

4.1.4 Groundwater Discharge

Groundwater discharges within the ML1535 include open pit dewatering and groundwater supply from ML1535 saline borefield. These are discussed in Section 4.3.1.

The Mine Site Model domain lies outside areas of known irrigation such as the Bland Creek Palaeochannel. Irrigation bores identified within the model developed by NOW (unknown publication date) for the Upper Lachlan catchment area all lie outside the Mine Site Model domain. Groundwater extraction due to irrigation is therefore not considered significant within the Mine Site Model.

It is understood a number of private stock and domestic bores also extract groundwater from the Upper Cowra Formation, however the extraction quantities are considered to be small and therefore considered unlikely to be significant within the Mine Site Model domain.

4.2 Numerical Model Development

Based on the Hydrogeological Conceptual Model presented in Section 4, a transient three-dimensional finite element model for simulation of groundwater flow and transport of solutes in the subsurface was developed. The existing model was updated with recent conditions. This section discusses the original model development and updates.

Following review of existing modelling software platforms and existing Coffey models for CGO, the finite element software package FEFLOW 6.0, developed by WASY GmbH (now DHI-WASY), was identified as a suitable software platform for this modelling project.

4.2.1 Model Domain, Layers and Discretisation

The model domain covers the same domain as the Mine Site Model Hydrogeological Conceptual Model discussed in Section 4.1. A three-dimensional schematic representation of the Hydrogeological Conceptual Model of the study area is shown in Figure 17.

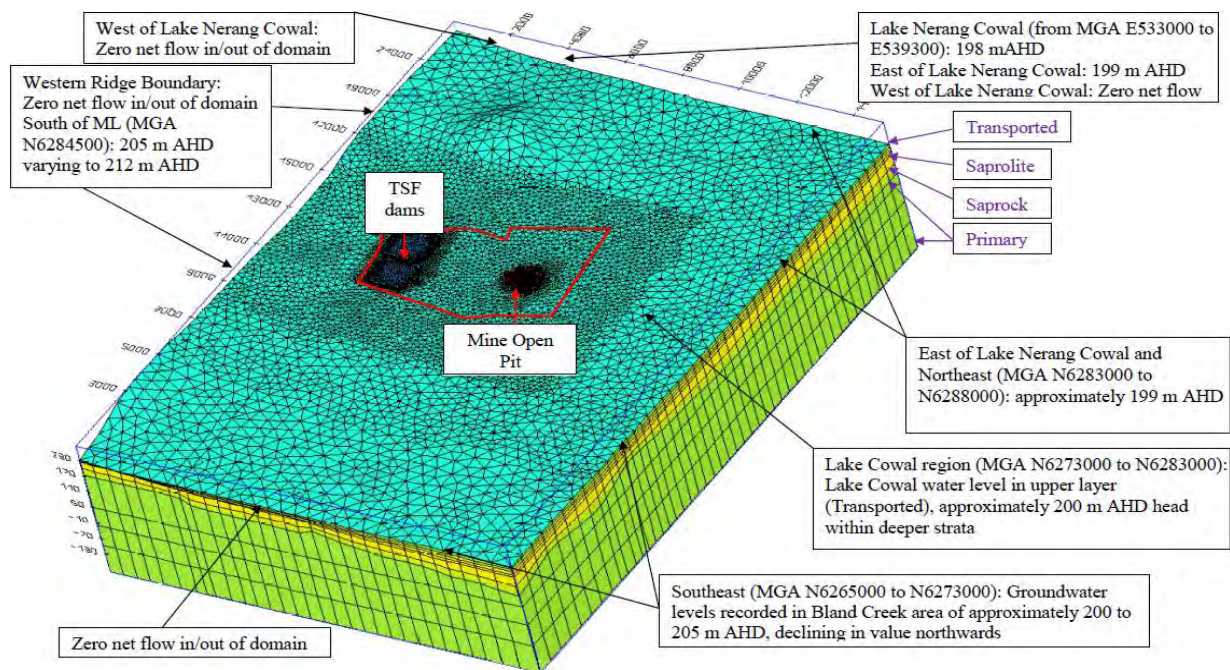

Figure 17 – 3D Representation of Model Domain and Boundary Conditions.

The model domain was discretised in a three-dimensional finite element mesh comprising 14 layers. The total number of elements in the mesh is 265,062. Figure 18 displays the model mesh. Drawn in red is the ML boundary.

The depth of the model extends from ground surface elevation to -500 m AHD, covering the proposed base depth of the open pit at -331 m AHD from 2020. The modelled area covers 370 square kilometres (km²).

The 14 model layers were divided over the Transported, Saprolite, Saprock and Primary Rock hydrogeological units. This division of layers permits future refinement of the model layers (e.g. further subdivision of hydrogeological units) to be made with greater ease. The division is as follows:

- The Transported hydrogeological unit is represented by the top three layers, each with equal thickness, except over the TSF areas where:
 - the base area of each dam in model Layer 1 is assigned properties in accordance with the deposited tailings material (Table 11);
 - the perimeter wall of each dam in model Layer 1 is assigned properties in accordance with the TSF embankment clay material (Table 11); and
 - the base area of each dam in model Layer 2 is assigned a 1 m thick liner with properties in accordance with the TSF embankment fill material (Table 11).
- The Saprolite hydrogeological unit is defined as model Layers 4 and 5 and the Saprock hydrogeological unit is defined as model Layer 6, except that the model considers the presence of Primary Rock to the west of the Gilmore Suture for these three layers (Primary Rock is interpreted to outcrop near the surface west of the Gilmore Suture).
- The Primary Rock hydrogeological unit is assigned for model Layers 7 to 14.

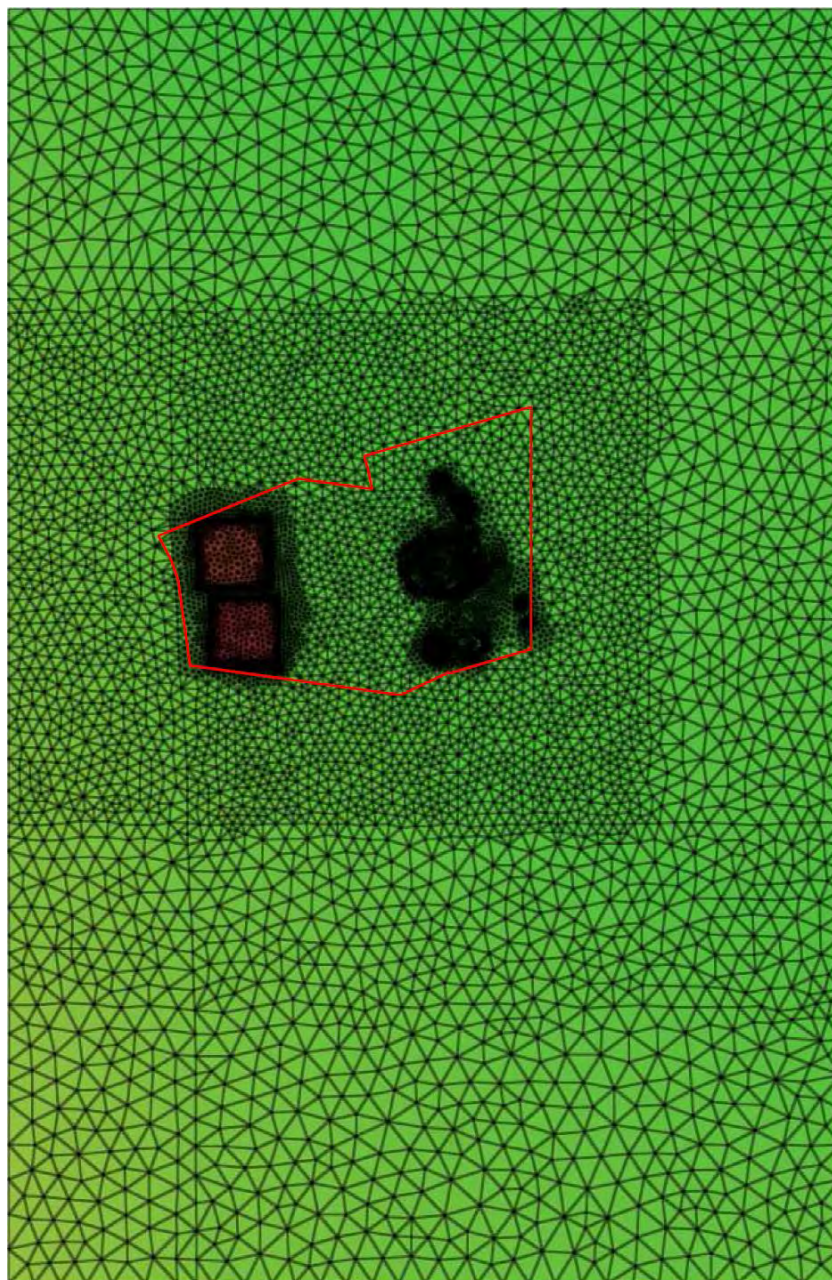

Figure 18 – Mine Site Numerical Model Mesh.

Topographic (ground surface) elevations and the base elevations of the Transported, Saprolite and Saprock hydrogeological units were provided from mine records for the ML 1535 area. Topographic surface was also provided (at lower resolution) for the wider region. The surfaces of hydrogeological units were linearly extrapolated from the boundaries of ML 1535 to regions outside ML 1535. Figures A-1 to A-4 show the model adopted surface contours for ground surface level, and the base of the Transported, Saprolite and Saprock units, respectively.

Mesh sizes were designed to meet the following criteria:

- Mesh cell sizes were refined around the open pit to allow effective simulation of dewatering and water level changes in the surrounding area.
- Mesh cell sizes were refined around the TSF dams to allow effective simulation of water level changes in these areas.
- Small mesh sizes were used in the vicinity of the open pit.
- Mesh cell densities were reduced in areas where groundwater conditions were less important for accomplishing modelling objectives, or where data relating to the characteristics of the groundwater system were sparse, or where resolution was unlikely to significantly improve simulation outcomes. Cell density reductions achieved significant decreases in model processing time.

The transient model time step varied throughout numerical simulation, depending on convergence of the model solution, but was restricted to a maximum allowable time step of 10 days.

4.3 Model Calibration

The groundwater model employed for this work was subject to calibration studies during the earlier work. This is described in Coffey (2013). A steady state model was developed to provide initial groundwater head values for the transient model.

Transient calibration considered the period 1 January 2005 (pre-mine-development) to 1 January 2013. Simulations were performed in the saturated unconfined aquifer FEFLOW mode. The calibrated model used in the pit dewatering assessment (Coffey, 2008) utilised similar aquifer parameters to those estimated from field data (Coffey, 2008, 2009a). Transient calibration adopted parameter values over the same ranges as those reported in Tables 7 and 8. Given the approximately north-south faulting in the region (Figure 7), the horizontal hydraulic conductivity was considered to be anisotropic within the rock units.

Extensive calibration of open pit boundary conditions and aquifer properties was undertaken. Calibration to groundwater monitoring and recorded dewatering flow rates was conducted with particular focus on the influence of:

- hydraulic conductivities and storativity within the Transported, Saprolite, Saprock and Primary Rock units;
- net accession (recharge and evaporation) rates; and
- varying combinations of seepage boundary conditions (with varying combinations of seepage (drainage) conditions located at the base of the Transported, Saprolite and Saprock units) and varying spatial sizes of “pit sump” time-varying head boundary conditions.

4.3.1 Model Boundary Conditions

4.3.1.1 Recharge and Surface Water Bodies at Mine Site

As adopted for earlier work a recharge rate of 0.3% mean annual rainfall has been adopted for the domain. Except for the TSF, surface water bodies on-site are not considered likely to impact groundwater conditions significantly and therefore have not been included in the model. This is consistent with treatment in earlier modelling studies. The model adopts the water levels (time-varying constant head boundary conditions) within the northern and southern tailings storage facility shown in Figure 16.

The inundation of Lake Cowal is represented in the model by application of a constant head boundary condition (with values in accordance with Figure 19) at ground surface (model Layer 1) over the area of Lake Cowal for the period over which Lake Cowal was observed to be inundated.

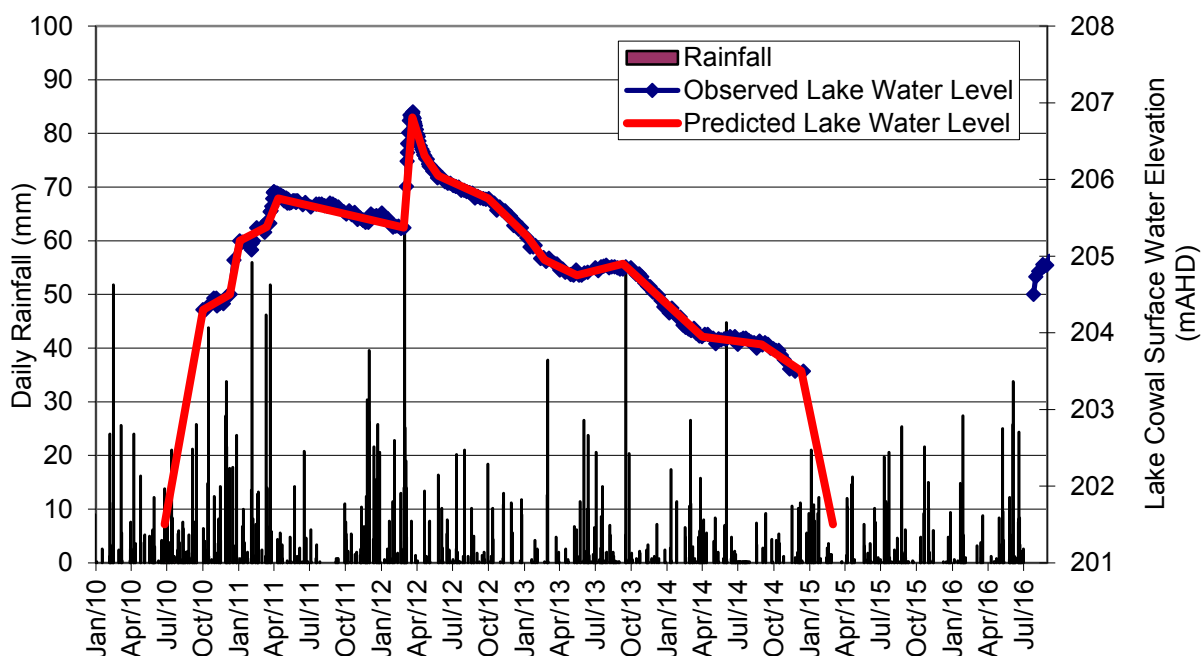

Figure 19 – Adopted Water Levels for Lake Cowal.

4.3.1.2 Model Domain Boundaries

Transient model boundary conditions adopted at the boundaries of the model domain were as follows:

- The Cowal West Hill ridge was adopted as the western boundary. At the western model boundary, a constant (with respect to time) head condition from 212 m AHD in the south, falling in value to 205 m AHD approximately 1.8 km north of the mine site, over all layers.
- At the northern model boundary, a constant head at Nerang Cowal of 198 m AHD, and a constant head of 199 m AHD to the east of Nerang Cowal, over all layers.

- The Bland Creek Palaeochannel was adopted as the eastern boundary of the model domain. Lake Cowal is understood to have been dry during 2005. Over the area covered by Lake Cowal, a groundwater level of 200 m AHD (some 1.5 m below lake bed level) was adopted for dry lake conditions; this is consistent with the range of groundwater head elevations modelled by the Bland Creek Palaeochannel Model in this area. Constant (with respect to time) head boundary conditions ranging from 200 m AHD within Lake area to (i) 199 m AHD in the north, and (ii) 205 m AHD in the south, were applied to the north and to the south of Lake Cowal, respectively.
- No-flow boundaries at all other model domain extremities over all layers.

4.3.1.3 Open Pit

The open pit was modelled using seepage face and constant head boundary conditions in three stages. The stages correspond with significant lateral expansion of the open pit, the installation of significant numbers of horizontal dewatering bores, and the inundation of Lake Cowal. The periods of the three stages are:

- beginning of mine life to March 2008 (when the open pit expanded significantly and significant numbers of horizontal bores were installed);
- March 2008 to June 2010 (when the lake began to fill); and
- June 2010 to December 2012.

The progressive deepening of the open pit was represented by a time-varying constant head boundary condition which was applied equal to the base elevation of the pit over a base region within the pit (in model Layer 10 for Stages 1 and 2, and model Layer 11 for Stage 3; those model layer elevations are consistent with the base elevations of the open pit of the stage periods). The elevation of the pit base during the life of the Modification is shown in Figure 13.

The progressive widening of the open pit was represented by applying a seepage boundary condition ring around the exposed pit face at the base of the Transported, Saprolite and Saprock units, which expanded over the three modelling stages in order to represent the progressive lateral expansion of the open pit. The seepage face boundary conditions applied in the pit area are shown in Figure 20.

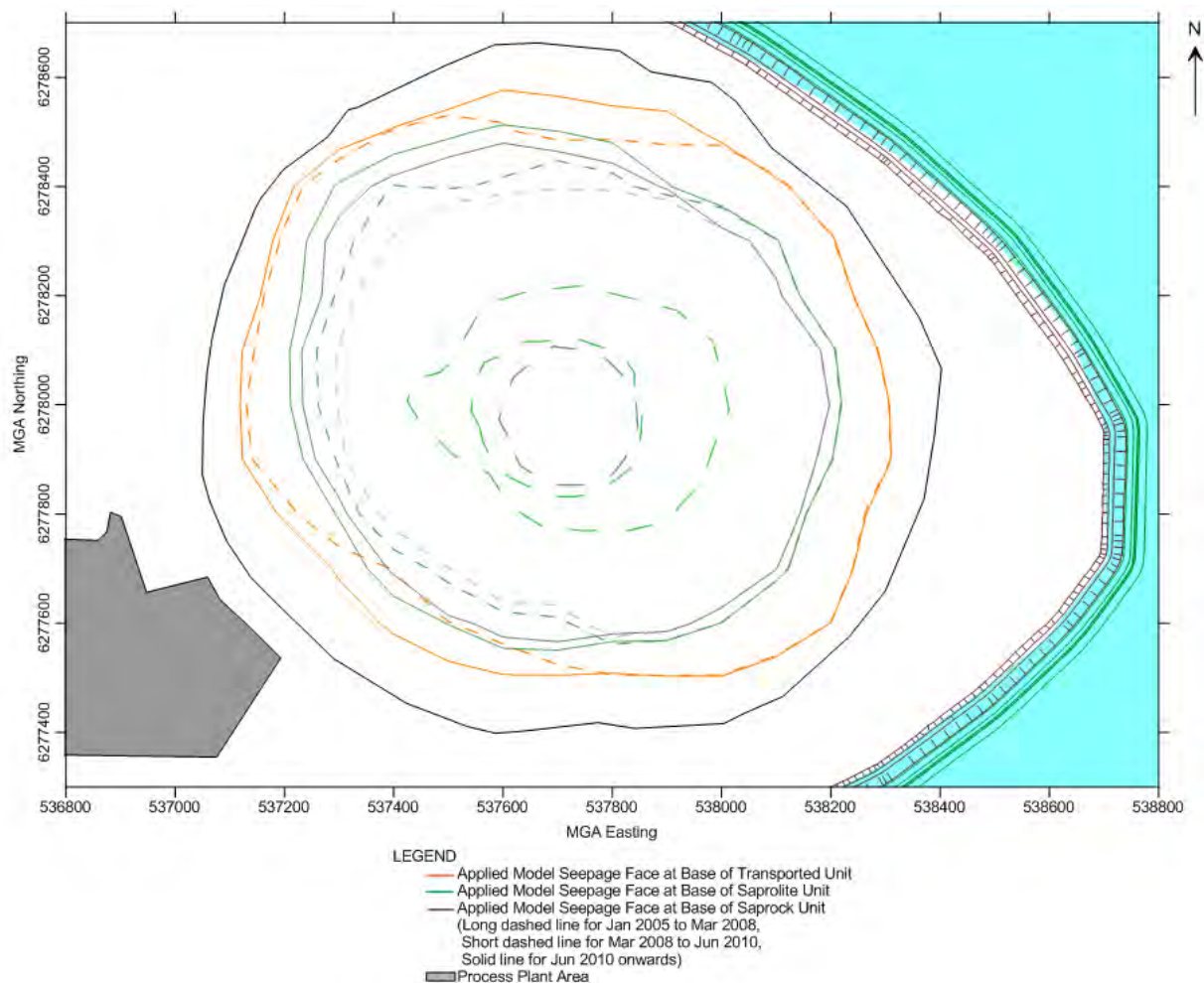

Figure 20 – Open Pit Model Seepage Boundary Conditions

4.3.1.4 Dewatering Bores

The dewatering bores included in the model are listed in Table 14 (and their locations are shown in Figure 12). The locations of the modelled dewatering bores (PD1 to PD14) provide reasonable representation of the locations of dewatering bores throughout the mine life, including the dewatering bores PD101 to PD107 commissioned in November 2011 (which are located in the vicinity of PD1 to PD10).

The total recorded monthly pumping rates from January 2005 to June 2016 for all dewatering bores were divided equally among the 13 bores included in the model. The adopted pumping rates are shown in Figure 21.

Table 14. Pit Dewatering Bores Used for Transient Calibration

| Bore Identification | MGA Northing | MGA Easting | Screen Interval (m AHD) |
|---------------------|--------------|-------------|-------------------------|
| PD1 | 538259 | 6278229 | 204.3 to 141.3 |
| PD2 | 538327 | 6277974 | 204.2 to 105.2 |
| PD3 | 538324 | 6277875 | 204.3 to 113.8 |
| PD4 | 538325 | 6277786 | 204.4 to 100.4 |
| PD5 | 538310 | 6277688 | 204.3 to 114.3 |
| PD6 | 538243 | 6277578 | 204.3 to 113.3 |
| PD7 | 538178 | 6277523 | 204.4 to 108.0 |
| PD8 | 538068 | 6277459 | 204.4 to 108.9 |
| PD9 | 537958 | 6277434 | 204.5 to 116.5 |
| PD10 | 537863 | 6277430 | 204.6 to 112.1 |
| PD11 | 537713 | 6277428 | 205.1 to 120.1 |
| PD12 | 537520 | 6277490 | 211.0 to 135.5 |
| PD14 | 537243 | 6277944 | 210.9 to 133.9 |

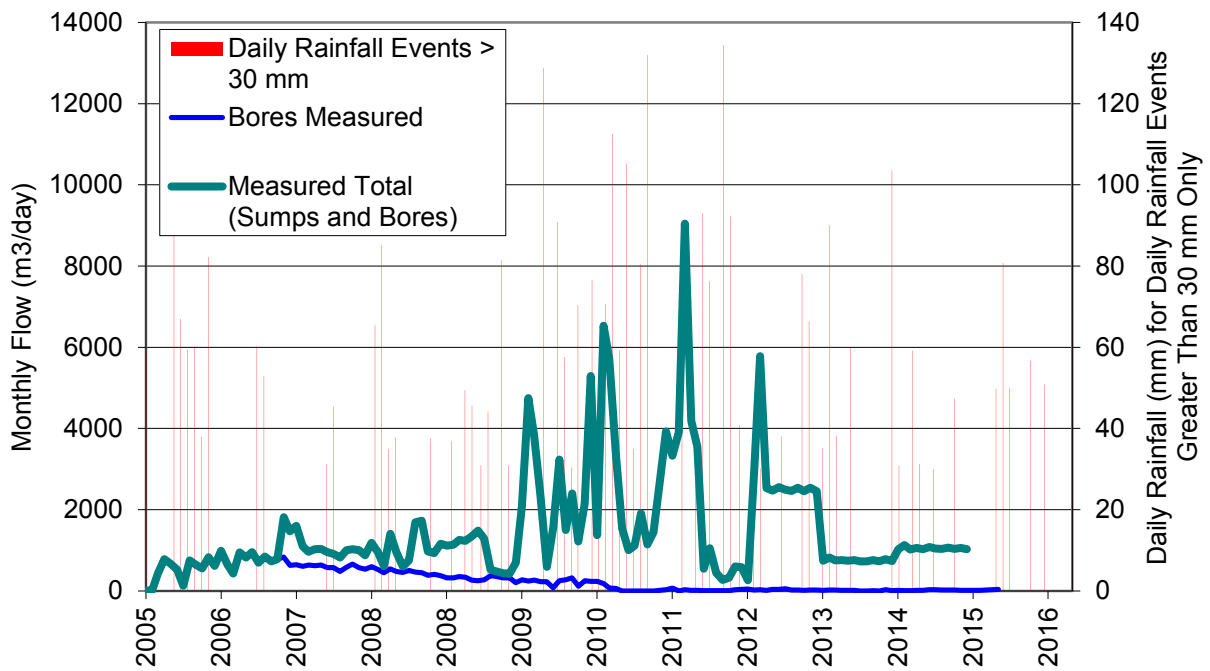

Figure 21 – Pit Dewatering Rates and Rainfall.

4.3.1.5 Groundwater Supply Extraction

ML 1535 saline groundwater supply bores (see Figure 11 for bore locations) may exert influence on the groundwater drawdown behaviour and were therefore included within the model. The following conditions were applied to ML 1535 saline groundwater supply bores located within ML 1535:

- Groundwater extraction from WB01 and WB20 occurred at 0.5 megalitres per day (ML/day) and 0.13 ML/day, respectively for five days per week, during September 2008 (equivalent continuous pumping rate of 0.35 ML/day and 0.09 ML/day, respectively).
- After September 2008, groundwater was not extracted from WB20.
- After September 2008, groundwater extraction from WB01 occurred at 0.5 ML/day for five days per week from December 2008 to April 2010 (equivalent continuous pumping rate of 0.36 ML/day).
- From April 2010, groundwater was not extracted from the saline supply bore field due to Lake Cowal being inundated (this situation continued for the remainder of the calibration period).

4.3.1.6 Summary of Applied Boundary Conditions

A summary of the applied boundary conditions for the transient model is provided in Table 15.

Table 15. Summary of Boundary Conditions Employed in Transient Numerical Model

| Boundary Location | Boundary Condition Type and Values Adopted | |
|-------------------|--|--|
| Surface | Recharge rate: | 0.3% of mean annual rainfall (1.44 mm/day) |
| Eastern Boundary | Bland Creek Palaeochannel: constant head from 199 m AHD to 205 m AHD, except at the boundary locations at which Lake Cowal is present | |
| Southern Boundary | No-flow | |
| Western Boundary | Cowal Hill Ridge: constant head from 205 m AHD in the north to 212 m AHD in the south (calibrated from steady state model) | |
| Northern Boundary | Over Nerang Cowal, a fixed head of 198 m AHD, a no-flow boundary west of Nerang Cowal, and a constant head of 199 m AHD east of Nerang Cowal | |
| Lake Cowal | Time-varying constant head in Layer 1 (see Figure 19) | |
| Open Pit | Base elevation of the pit: | Time-varying constant head in Layers 10 or 11 (see Figure 13) |
| | Pit walls: | Seepage face boundary (drain) in Layers 4, 6 and 7 (see Figure 20) |
| TSF | Southern and northern tailings storage facilities: | Time-varying constant head (see Figure 16) |

Mm/day = millimetres per day.

4.3.1.7 Model Assumptions

The following assumptions were employed in the model:

- the Mine Site Model does not include regional areas over which significant groundwater pumping by private owners occurs (e.g. irrigation over farmland);
- the open pit is assumed to be dry (not flooded) during mining (observed conditions on-site support this assumption);
- changes in deposited tailings materials (e.g. due to consolidation or operation processes) were not considered;
- the Jemalong and eastern saline supply borefields are at sufficient distance for drawdown impacts not to affect groundwater levels at the mine site;
- deposited tailings are not removed from the TSF; and
- the TSF and Lake Cowal are the only surface water bodies within ML 1535 exerting significant impact on groundwater levels.

4.3.1.8 Calibration

The calibration process involved changes to model parameters to better match model outputs with measured response. The results for the adopted model after the calibration process are discussed below.

Figures A-16 to A-18 show modelled and observed groundwater levels at the locations of the groundwater monitoring piezometers for the calibrated model.

The modelled groundwater levels and trends are generally consistent with those observed. Modelled levels are slightly elevated in some piezometers near the TSF (Figure A-18).

Modelled groundwater levels at piezometers PDB3A are somewhat elevated relative to observed groundwater levels. This is likely due to the influence of horizontal bores (W911 and W912) in the pit, which are located relatively close to the PDB3 piezometers and likely cause significant localised drawdown that may not be representative of other areas in the vicinity of the pit. As the horizontal bores (drains) are not modelled explicitly, these localised effects are not shown in the calibration results. As that impact is expected to be localised, the calibration results are considered reasonable.

At greater distance from the open pit, modelled groundwater levels in piezometers PDB1A and PDB1B (Figure A-16) compare favourably with observed groundwater levels. Modelled groundwater levels in piezometers PDB5A and PDB5B (Figure A-16) compare reasonably well with observed groundwater levels, although the rise in PDB5B (screened in the Transported unit) is slightly underestimated.

Modelled groundwater levels in piezometers located in the processing plant area (Figure A-17) overestimate the drawdown in ground water levels in the vicinity. Hence, the predictions are considered somewhat conservative.

Predictions of groundwater levels in the vicinity of tailing storage facilities shows a similar pattern to those observed, with some having fairly good agreement with the measured data. Near the northern tailings storage facility, the predictions are overestimating the groundwater levels at piezometers TSFNA, TSFNB, TFSNC and MON01A while the predictions for P561B under predicts the groundwater level. For southern tailings storage facility, a slight over prediction of groundwater levels could be observed.

In general, the modelled groundwater levels and rates of drawdown compare favourably with those observed. The aquifer parameters adopted in the model are shown in Table 16 and were employed for the predictive modelling. For available data, aquifer parameter values lie within two orders of magnitude of those adopted in previous studies (Tables 7 and 8).

Modelled groundwater head contours for the Transported (Layer 3), Saprolite (Layer 5), Saprock (Layer 6) units, and mid-Primary Rock (Layer 11) unit at the end of the calibration period (June 2016) are presented in Figures A-19 to A-22. Groundwater levels fall in the vicinity of the pit but the extent of drawdown is generally limited to the ML 1535 area. When compared against groundwater heads observed prior to mine development, the influence of drawdown in June 2016 is clearly confined to within the modelled domain.

Table 16. Adopted Model Parameters

| Model Layer(s) | Hydrogeological Unit | Hydraulic Conductivity (m/day) | | | Specific Storage (m ⁻¹) | Specific Yield (-) |
|----------------|----------------------|--------------------------------|-------------------------------|---------------------------|-------------------------------------|----------------------|
| | | K _{xx} (east-west) | K _{yy} (north-south) | K _z (vertical) | | |
| 1 to 3 | Transported Material | 1.0×10 ⁻² | 1.0×10 ⁻² | 6.5×10 ⁻⁴ | 5×10 ⁻⁴ | 1.5×10 ⁻¹ |
| 4 and 5 | Saprolite* | 3.4×10 ⁻² | 1.7×10 ⁻² | 1.7×10 ⁻² | 5×10 ⁻⁵ | 1.0×10 ⁻⁴ |
| 6 | Saprock* | 4.0×10 ⁻³ | 2.0×10 ⁻³ | 2.0×10 ⁻³ | 3×10 ⁻⁵ | 1.0×10 ⁻⁴ |
| 7 to 14 | Primary Rock | Varies [^] | Varies [^] | 5.0×10 ⁻⁴ | 2×10 ⁻⁵ | 1.0×10 ⁻⁴ |
| 1 | TSF Embankment Clay | 4.3×10 ⁻¹ | 4.3×10 ⁻¹ | 4.3×10 ⁻² | 5×10 ⁻⁴ | 1.5×10 ⁻¹ |
| 1 | Deposited Tailings | 5.0×10 ⁻² | 5.0×10 ⁻² | 5.0×10 ⁻⁴ | 5×10 ⁻⁴ | 1.5×10 ⁻¹ |
| 2 | TSF Foundation | 1.0×10 ⁻⁴ | 1.0×10 ⁻⁴ | 1.0×10 ⁻⁴ | 5×10 ⁻⁴ | 1.5×10 ⁻¹ |

* Parameter values applied over domain to the east of Gilmore Suture. West of the Gilmore Suture, Primary Rock values apply for the layer.

[^] Primary rock horizontal hydraulic conductivity reduces with depth. K_{xx} varies from 2.3×10⁻³ m/day in Layers 7 to 10, reducing approximately linearly to 5×10⁻⁴ m/day in Layers 14 to 15. K_{yy} is consistently double the value of K_{xx} in Layers 7 to 13.

The modelled and interpreted average monthly total dewatering rate (vertical dewatering bores plus pit face seepage inflows) are shown in Figure 22. Measured dewatering rates compare favourably with modelled rates, providing confidence in the model's ability to accurately represent groundwater flow conditions.

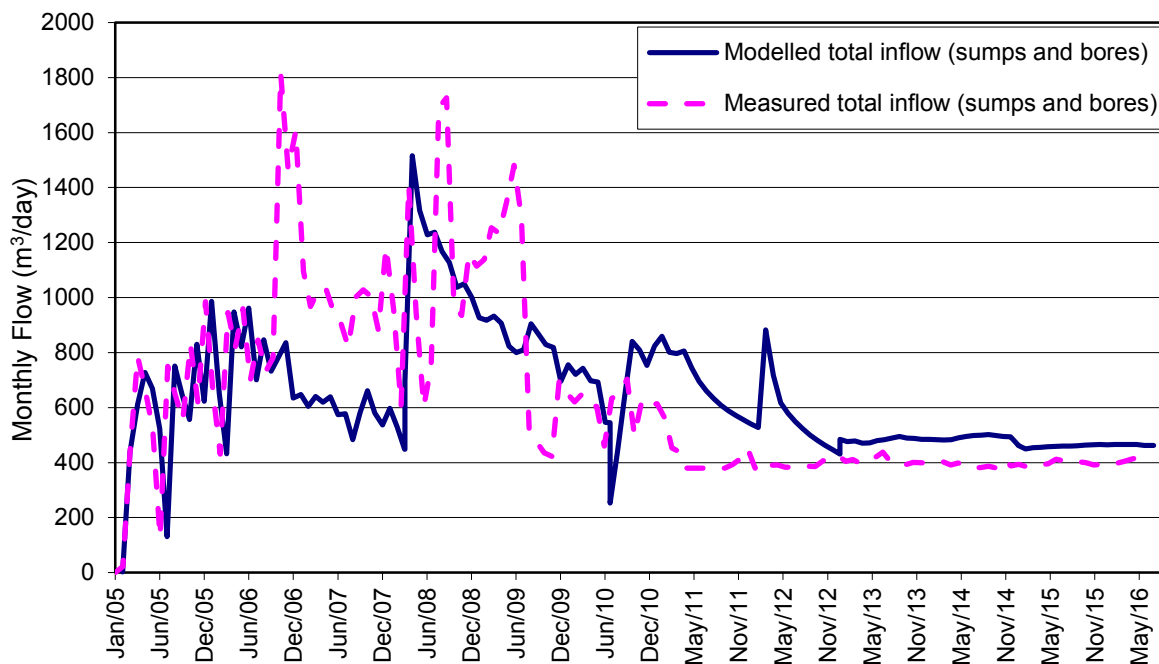

Figure 22 – Calibration Open Pit Inflows.

4.4 Predictive Groundwater Flow Modelling

The calibrated model was utilised to predict groundwater flow and drawdown for the Modification. Two scenarios were considered: Lake Cowal being either dry or inundated.

4.4.1 Modelled Conditions

4.4.1.1 Lake Cowal

For the inundated Lake Cowal scenario, a lake water level of 205.8 m AHD was assumed to exist in perpetuity over the lake area.

For the dry Lake Cowal scenario, the lake level was considered to fall consistent with Figure 19, until it became dry in April 2016, after which time it remained dry. Coffey acknowledges that Lake Cowal began to fill again in late July 2016 but for the purpose of consideration of the bounding case of dry conditions in Lake Cowal a simulation was carried out with Lake Cowal dry beyond April 2016.

4.4.1.2 Open Pit

The base elevation of the pit was modelled consistent with that shown in Figure 13, using a constant head boundary condition in model Layer 13. Adopted pit seepage boundary conditions were identical to those used in the calibrated model.

4.4.1.3 Tailings Storage Facilities

The tailings dams were assumed to continue rising as shown in Figure 16.

4.4.1.4 ML 1535 Saline groundwater Supply Bores

Groundwater is extracted from the saline supply borefield only when Lake Cowal is dry. Therefore, only the dry scenario considered abstraction.

For the dry scenario, abstraction was modelled from the saline supply borefield at a rate of 1 ML/day for five days per week (equivalent continuous pumping rate of 0.71 ML/day) from February 2016 to the end of the simulated period.

4.4.1.5 Open Pit Dewatering Bores

Since the commissioning of vertical dewatering bores PD101 to PD107 in November 2011, the dewatering flow rate from the vertical dewatering bores has averaged 19 m³/day, approximately 5% of the total pit dewatering flow rate (see Figure 21). The vertical dewatering bores are therefore not considered to provide a significant contribution to pit dewatering from November 2011 and were therefore not included in the forward predictions.

4.4.2 Predictive Modelling Results

4.4.2.1 During Mining

Over the future life of the mine, predicted groundwater levels in the immediate vicinity of the open pit continue to fall in all units due to increasing excavation of the pit. In the vicinity of the TSF, groundwater levels tend to rise in response to the increased water levels within the storage facilities.

For the dry lake scenario at the end of mine life (June 2032). Figures A-23 to A-26 display model predicted groundwater head contours for the Transported (Layer 3), Saprolite (Layer 5), Saprock unit (Layer 6) and Primary Rock (Layer 11) units respectively. The same modelling results for the inundated lake scenario are shown in Figures A-27 to A-30.

Figures A-31 to A-38 reveal that:

- The predicted groundwater drawdown under a dry lake scenario extends approximately 400 m further to the east relative to the inundated lake scenario, due to the absence of the lake.
- The predicted groundwater drawdown due to groundwater extraction from ML 1535 saline groundwater supply borefield is insignificant relative to the groundwater drawdown induced by the open pit.
- Significant groundwater drawdown predicted by the model is generally limited to within ML 1535 (to the proposed mine closure) for both dry and inundated lake conditions.
- When compared against groundwater heads observed prior to mine development (shown in Figures A-8 to A-15), the influence of drawdown at the end of mine life is limited to within the confines of the modelled domain.

The modelled average monthly total dewatering rate (vertical dewatering bores plus groundwater seepage) to mine closure is shown in Figure 23 for both the dry and inundated lake scenarios. Because the modelling was conducted in numerous stages, modelling outputs have been interpreted considering the transitions in rates between each model stage.

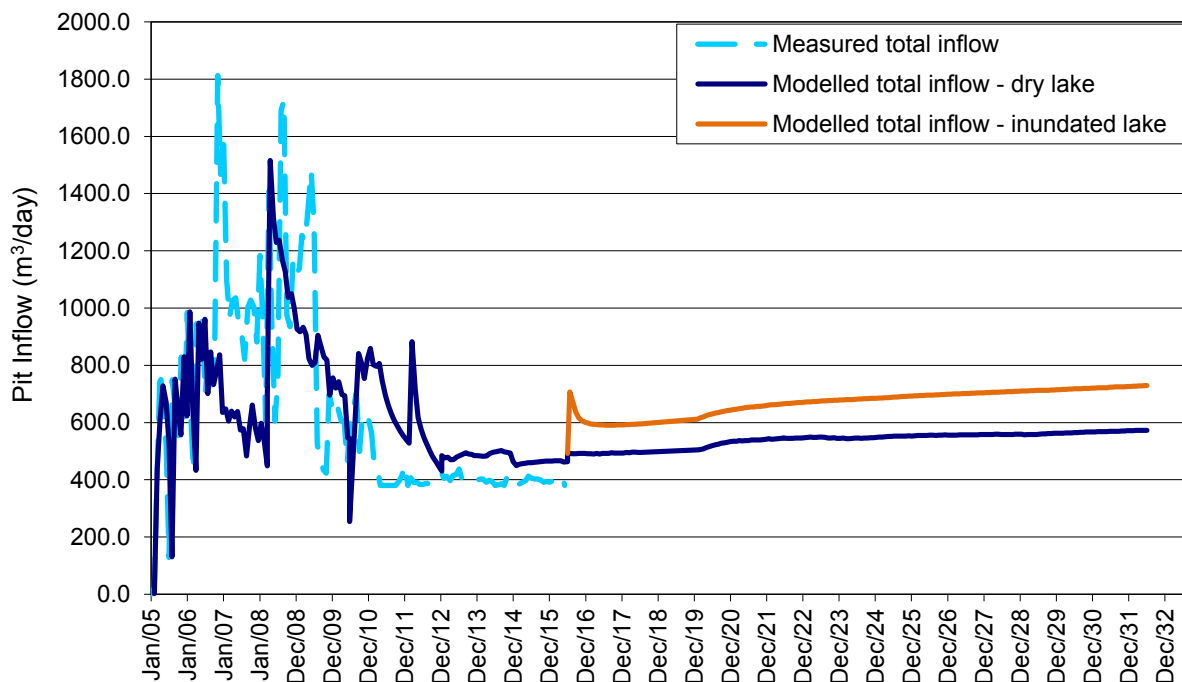

Figure 23 – Model Predicted Inflow to Open Pit

Groundwater inflows to the open pit range between approximately 500 m³/day and 700 m³/day between 2016 and mine closure. A difference of approximately 150 m³/day is observed between dry and inundated lake scenarios. This difference results from the very low rates of seepage over the extensive lake area for the lake full scenario.

4.4.2.2 Post-Mine Closure

Post-mine closure, the open pit is expected to gradually fill with water (from groundwater seepage and rainfall), attaining a long-term equilibrium level that will depend on the competing effects of groundwater seepage and rainfall inflowing to the pit and evaporative losses.

Figures A-39 to A-42 present model-predicted groundwater drawdown (relative to pre-mining conditions) 20 years after mine closure (2052) for, respectively, the Transported unit (Layer 3), Saprolite unit (Layer 5), Saprock unit (Layer 6) and Primary Rock unit (Layer 11) units for the dry lake scenario. (Groundwater drawdown is presented for the dry lake scenario because it is greater than for the inundated lake scenario).

These predictions represent a conservative estimate of groundwater drawdown, since the modelling assumes the open pit remains empty and modelled groundwater inflows to the pit are therefore higher than expected.

The predicted groundwater drawdown for all units at 20 years after mine closure (2052) is not significantly different from the drawdown at the end of mine life (2032).

4.4.2.3 Potential Impact on Lake Cowal

The presence of the open pit void is expected to induce additional vertical seepage from Lake Cowal (towards the void) over the long-term.

The model was used to predict the long-term (steady state, post-mine closure) vertical leakage from Lake Cowal considering the lake was inundated in the presence of the open pit void. The model-predicted vertical leakage over the lake area was $3.7 \times 10^{-6} \text{ m}^3/\text{day}/\text{m}^2$ (of the order of 0.1% of the losses apparent from the monitoring of water level decline in the lake after filling averaging between 3 and 4 mm/d). This equates to a seepage rate of some 4 litres per second (L/s) over the entire lake and is relatively consistent with the findings of Coffey (1997). The leakage under these conditions is insignificant, particularly when compared to the total lake storage and evaporation losses under natural conditions. For all practical purposes the lake bed sediments (and the Lake Protection Bund) act as an impeding layer to vertical leakage from the lake.

The impact of the open pit, pit dewatering and groundwater extraction from the mine lease saline supply borefield on the waters of Lake Cowal is therefore considered negligible.

4.4.2.4 Model Sensitivity

Coffey expects the sensitivity of the model to be in line with the observed sensitivity of previous groundwater models simulating ML 1535. During the sensitivity analyses conducted on both horizontal and vertical hydraulic conductivity: increasing them by a factor of two; it was observed that the extent of groundwater drawdown in the hydrogeological units increases with increased hydraulic conductivity, and drawdown associated with ML1535 saline supply borefield increases. However, significant drawdown (>2 m) remains within ML1535.

4.5 Groundwater Quality Related to Open Pit Dewatering

The quality of groundwater collected by the dewatering system (including groundwater both pumped from vertical dewatering bores and seeping into the open pit) is expected to be similar to existing groundwater quality and would be used as a water supply for the processing plant. The expected concentration/value range for a number of analytes is provided in Table 17. Pit dewatering will only have a small and localised (i.e. within the ML) impact on groundwater quality.

Table 17. Expected Dewatering Groundwater Quality

| Analyte | Concentration (mg/L) or Value |
|--------------------------|-------------------------------|
| pH | 5.8 to 7.1 |
| Dissolved sodium | 8,000 to 13,000 |
| Sulphate | 2,500 to 7,000 |
| Alkalinity (bicarbonate) | 80 to 500 |

5 CONTAMINANT MIGRATION

This section discusses the potential impact to water quality in the vicinity of the TSFs through seepage of stored water.

5.1 Seepage from Tailings Storage Facilities

The mean vertical leakage from the northern and southern tailings storage facility, respectively, in 2012 is estimated using the model to be 180 m³/day and 220 m³/day.

The mean vertical leakage from the northern and southern tailings storage facilities, respectively, predicted by the model is approximately 250 m³/day and 280 m³/day over the future mine life (2013 to 2024). This is equivalent to approximately 0.21 m³/day/m and 0.23 m³/day/m in cross-section across for the northern and southern tailings storage facilities, respectively, which is consistent with the values of 0.12 m³/day/m and 0.45 m³/day/m reported in the EIS at two different sections across the northern and southern tailings storage facilities (North Limited, 1998).

5.2 Potential Impact on Groundwater Quality

Assessment of potential impacts to groundwater quality due to seepage from the TSFs water was undertaken using an analytical particle tracking approach. The assessment did not include geochemical processes such as sorption, chemical oxidation and degradation reactions that may hinder contaminant migration. This approach provides a conservative estimate of the likely contaminant travel times through the subsurface because processes of sorption, chemical oxidation and degradation delay to otherwise reduce the mobility of groundwater chemical changes.

Groundwater flow conditions at mine closure for the inundated lake case were considered. Such conditions lead to a conservative assessment, since water levels in Lake Cowal are high under this scenario and therefore potentially induce greater flows than when Lake Cowal is dry.

Groundwater seepage velocities within the most permeable unit (Saprolite) in the vicinity of the TSFs were calculated based on long-term model-predicted groundwater heads and assuming a (conservative) Saprolite effective porosity of 1%.

Figure A-43 displays the possible extent of groundwater quality changes after 50 and 100 years, assuming groundwater begins moving from immediately outside the TSFs wall. After 100 years, the potential for groundwater quality changes due to seepage from the TSFs stored water extends a distance of approximately 2 km from the TSF wall. This was assessed based on the results of modelling of an earlier pit expansion. The present case will not materially change the overall long term flow regime as water level will recover in the pit to a similar level controlled by the balance of groundwater inflow and evaporative losses.

Cyanide is used in the gold extraction process and is present in tailings released to the TSF. The groundwater monitoring results suggest that, as of June 2016, there is no consistent trend to suggest that significant concentrations of cyanide have leached from the TSF into the surrounding groundwater. Cyanide is therefore considered unlikely to be present within groundwater over the site (outside the TSF).

Earlier work indicated that cyanide would not reach beyond 2 km from the TSF wall before 100 years. This assessment represents a conservative case, since cyanide associated with potential seepage from the TSF degrades due to hydrolysis, volatilisation (to HCN gas), oxidation and biological activity. For this reason, and the fact that the assessment ignores the hindrance to solute migration imposed by the TSF liner, the likely groundwater transport of cyanide from the TSF is expected to be much more limited.

Schmidt *et al* (1981) measured an (equivalent) cyanide half life of 3.6 to 30 days in tailings liquors. Burden and Kidd (1987) found half life constants ranging from 36 to 300 days in laboratory-tested tailings mass. The EIS adopted a cyanide decay half-life of 300 days (North Limited, 1998). Thus, cyanide concentrations at the extent of the 100 year potential groundwater quality change contour shown in Figure A-43 are likely to be essentially zero.

The transport of cyanide through groundwater is further retarded due to sorption processes. The EIS adopted a (conservative) cyanide retardation factor of four (North Limited, 1998). Data collected by Allison and Allison (2005) suggest cyanide partition coefficients for soil-soil water range from approximately 4×10^{-3} litres per kilogram (L/kg) to 20 L/kg (mean 5 L/kg). Assuming clay-like (Transported or Saprolite unit) material with bulk density of up to 1.3 t/m³ and effective porosity ranging from 1 to 30%, retardation factors may range from 1 to well above 2,000, and a mean value of around 600. These retardation factors indicate transport of cyanide would be significantly impeded over the site.

The EIS reported a potential migration of cyanide (at 0.1% of tailings source concentration) to 200 m eastwards from the TSF after eight years, for high permeability aquifer materials and a cyanide retardation factor of four and decay half life of 300 days (North Limited, 1998). In the long-term, cyanide would degrade in the tailings storage and surface of the underlying aquitard and would be effectively removed from the subsurface. This assessment is less conservative than the above assessment (which does not explicitly consider retardation or decay).

In addition to cyanide, other contaminants such as arsenic, zinc and other heavy metals have the potential to be released from the TSF. Based on the analytical migration assessment, such contaminants would similarly not reach beyond 2 km from the TSF wall before 100 years. Again, to provide a conservative assessment of contaminant migration, biological processes and sorption of contaminants to the soil/rock matrix are not considered as these processes would further retard contaminant migration.

Figure A-44 shows long-term groundwater head contours and groundwater flow direction for the dry lake scenario. The flow directions for the inundated lake scenario are consistent with those for the dry lake scenario. Contaminants associated with potential seepage from the TSF would flow in the direction of the final pit void and ultimately terminate in that void. The final pit void therefore becomes a long-term sink for all groundwater within ML 1535. As a result, analytes are expected to concentrate within the pit voids over hundreds of years (e.g. water salinity in the pit will rise). Analytes associated with potential seepage from the TSF are expected to remain within groundwaters between the TSFs and the final void over the long-term.

6 GROUNDWATER LICENSING AND AQUIFER INTERFERENCE POLICY CONSIDERATIONS

6.1 Licensing

The NSW *Water Act, 1912* governs water licensing, and the trading and allocation of licences, for both groundwater and surface water resources in NSW where a water sharing plan has not been implemented. The *Water Act, 1912* applies to extraction of groundwater, extraction of water from a river, aquifer interference and capture of surface runoff to dams. The *Water Act, 1912* is in the process of being progressively phased out and replaced by the NSW *Water Management Act, 2000* (WMA). Water licensing and the Aquifer Interference Policy Considerations are also discussed in Attachment 2 of the EA.

Water Sharing Plans are statutory plans for specific water resource areas under the WMA that provide the rules for sharing and managing water resources in NSW. The *Water Act, 1912* is repealed for a water resource area once a Water Sharing Plan has commenced for that area, and existing licences are converted to new consents under the WMA.

- The *Water Sharing Plan for the Lachlan Unregulated and Alluvial Water Sources, 2012* commenced on 14 September 2012 and provides the framework for managing groundwater in the Lachlan aquifer until July 2023. The Bland Creek Paleochannel Borefield and Eastern Saline Borefield operated by CGO draw groundwater from the Lachlan Formation for mine use. These borefields lie within the Upper Lachlan Alluvial Zone 7 Management Zone. ML1535 lies within the Upper Lachlan Alluvial Zone 7 Management Zone.
- The *Water Sharing Plan for the NSW Murray Darling Basin Fractured Rock Groundwater Sources, 2011* commenced on 16 January 2012 and provides the framework for managing groundwater in the fractured rock aquifers until July 2022. ML1535 lies within the Lachlan Fold Belt groundwater source of the Murray-Darling Basin, and groundwater dewatering of and seepage to the open pit result in extraction of groundwater from the Lachlan Fold Belt (alluvial areas are excluded in this source area). Table 18 lists the statistics for the Murray-Darling Basin groundwater source as provided in the water sharing plan.

Groundwater removal from the fractured rock at the mine site is managed under a water sharing plan. The *Water Sharing plan for the Murray Darling Basin Fractured Rock Ground water sources* which commenced on 16 January 2012 was amended on 1 July 2016 to:

- Vary the amount of recharge reserved as planned environmental water as a result of recharge studies undertaken or assessed as adequate by the Minister.
- Modify the long term average annual extraction limits as a result of recharge studies undertaken or assessed as adequate by the Minister.
- Establish available water determination rules and individual access licence account management rules for major utility access licenses.
- Restrictions on the granting and amendment of water supply works to protect water dependent aboriginal cultural assets.
- Allow for the granting of aquifer interference approvals and the management of aquifer interference activities.

These changes to the water sharing plan do not affect the pre-existing licensing arrangements at the CGO.

Table 18. Requirements for Water Sharing (Murray-Darling Basin Fractured Rock– Lachlan Fold Belt Groundwater Source)

| Use | Share Component (ML/year) |
|---|--|
| Stock and domestic | 74,311 |
| Town water supply | 5,101 |
| Recharge | 189,362.54 (high environmental value areas) 3,285,001.88 (non-high environmental value areas) |
| Environmental water | 189,362.53 (high environmental value areas) 3,285,001.88 (non-high environmental value areas) |
| Long-term annual average extraction limit | 189,362.53 (high environmental value areas) 3,285,001.88 (non-high environmental value areas) |

ML/year = megalitres per year.

6.1.1 Mine Site Groundwater Extraction

The numerical modelling predicts monthly dewatering rates (due to open pit dewatering and seepage) as shown in Figure 22. The equivalent average annual groundwater take from 2016 to the end of mine life is approximately 200 ML/year. Peak dewatering flows (groundwater take) may exceed that value (by up to 40 ML/year) during major campaigns of horizontal drain (bore) installation in the open pit or vertical dewatering bore commissioning. The groundwater taken is predominantly sourced from the rock hydrogeological units.

As per the letter from Department of Primary Industries – Office of Water to CGO (then owners Barrick) titled “Cowal Gold Mine – Request for reallocation of water access licence under the water management act 2000” and dated 7 January 2014, the CGO holds licences to access 366 units share component in Lachlan Unregulated and Alluvial water sources and Upper Lachlan Alluvial Zone 7 Management Zone and another 3294 unit share component in the NSW Murray Darling Basin Fractured Rock Groundwater Sources.

The predicted annual groundwater volumes required to be licensed within each Water Sharing Plan for the Modification are summarised in Table 19.

Table 19. Groundwater Licensing Requirement Summary

| Water Sharing Plan | Management Zone/ Groundwater Source | Predicted Groundwater Inflow/Extraction Volume requiring Licensing (ML/year) | | |
|---|--|---|----------------------------|----------------------------|
| | | Existing | During Modification | Post-Mining |
| Water Sharing Plan for the Lachlan Unregulated and Alluvial Water Sources | Upper Lachlan Alluvial Zone 7 Management Zone | Maximum 275* | Maximum 280* | Average 1.4 Maximum 2.3 |
| NSW Murray Darling Basin Fractured Rock Groundwater Sources | Lachlan Fold Belt Groundwater Source | Maximum 167 | Average 222 Maximum 228 | Average 27 Maximum 44 |

* Includes 256 ML/year extraction associated with the saline supply bores within ML 1535.

6.2 Aquifer Interference Policy Requirements

6.2.1 Mine Site

NOW's *Aquifer Interference Policy* (September 2012) provides a framework for assessing the impacts of aquifer interference activities on water resources.

Aquifer Interference Policy (NOW, 2012) is relevant to CGO as it applies to mining activities such as open cut voids and the disposal of water taken from aquifers.

Groundwater quality within ML1535 has EC generally in the range of 30,000 microsiemens per centimetre ($\mu\text{S}/\text{cm}$) to 55,000 $\mu\text{S}/\text{cm}$ for the Transported, Saprolite and Saprock units. Data are not available for the Primary Rock, but the EC in the Primary Rock is expected to be similar (or higher due to the presence of salts in the rock). This equates to a TDS concentration of between 19,200 mg/L and 35,200 mg/L. The groundwater source at CGO is therefore defined by the *Aquifer Interference Policy* (NOW, 2012) as a:

...less productive groundwater source...

The minimal impact considerations specified in the *Aquifer Interference Policy* (NOW, 2012) for a less productive groundwater source include:

- (i) No more than a specified cumulative variation in the water table within 40 m from a high priority groundwater dependent ecosystem or a high priority culturally significant site.
- (ii) No more than a specified limited in the water table decline at any water supply work.
- (iii) No more than a specified cumulative pressure head decline at any supply work.
- (iv) Any change in groundwater quality that lowers the beneficial use category of the groundwater source beyond 40 m from the activity.
- (v) No increase of more than 1% per activity in long-term average salinity in a highly connected surface water source at the nearest point of activity.
- (vi) No mining activity below the natural ground surface within 200 m laterally from the top of the high bank and 100 m vertically beneath of a highly connected surface water source that is defined as a "reliable water supply".

The model predicted groundwater drawdown up to 20 years post-mine closure remains largely within ML1535. As there are no groundwater dependent ecosystems, priority culturally significant sites or supply works within ML1535 (or within 40 m of the boundary of ML1535), minimal impact considerations (i) to (iii) have been met.

The Schedule 4 of the Upper Lachlan Alluvial Groundwater Source Water Sharing Plans nominates two high priority GDEs (Bogolong Springs and Old Man Springs). These GDEs are located more than 60 km to the east of the mine, on the other side of the Bland Creek Palaeochannel from the mine. These GDEs are distant from the mine and would not be affected by mining operations.

A check carried out on 3 November 2016 on the BoM's Atlas of Groundwater Dependent Ecosystems identified the presence of stands of Dwyer's Red Gum (*Eucalyptus dwyeri*) 3 km to the north of the ML and 3.8 km to the south west of the mine pit as the closest ecosystems potentially dependent on subsurface groundwater. These are well outside the extent of influence on shallow groundwater predicted

using the results of groundwater modelling and as a result no impact on these ecosystems would occur over the mine life as a result of mine operation.

During the life of the mine, Pit dewatering will only have a small and localised (i.e within the ML) impact on groundwater quality. Over the longer term, groundwater will flow towards the open pit void, ultimately terminating there. This groundwater quality in the region surrounding the open pit void is not expected to change significantly due to this process, though the quality of the water within the open pit is expected to change (e.g. salinity will increase). The beneficial use of groundwater is not expected to change due to dewatering or the presence of the open pit void. Thus, minimal impact consideration (iv) is met.

Assuming that the equilibrium surface water level in the final pit void is not as high as ground surface, water from the pit void is not expected to be released (or used). Thus it is not classified as a highly connected surface water source, meeting minimal impact consideration (v).

Coffey is not aware of any “reliable water supplies” within 200 m laterally from the top of the high bank. Lake Cowal is an ephemeral lake, and is therefore not considered by Coffey to be a “reliable water supply”. Thus, minimal impact consideration (vi) is met.

7 MANAGEMENT AND MITIGATION MEASURES

7.1 Groundwater Levels around the Tailings Storage Facilities

Groundwater levels in piezometers in the vicinity of the tailings dams have shown increases in levels in recent years. Of these, the largest rises were recorded at MON02A and MON02B (screened in the Saprock and Saprolite units, respectively) which have displayed a gradual rise since late 2006. Groundwater level variation around the TSF was investigated by Coffey (2009a), where the rises were assessed to be related to the percolation and the movement of seepage from TSF.

Ground elevation at the MON02 piezometer nest is about 222 m AHD, about 11 m above the groundwater levels at MON02 in late 2015 (Northern Resource Consultants, 2016). The screen midpoints are at about 66 m and 27 m below ground at MON02A and MON02B respectively. The equality of water levels at these piezometers suggest minimal vertical hydraulic head gradients, with the potential for shallow hydraulic heads to be the same as deeper in the profile, at that location.

If the current trends were extrapolated linearly the water level at MON02A/ MON02B would reach the about 215.5 m AHD at the end of 2025. This provides sufficient time to develop and design mitigation measures should they prove necessary. Following mine closure the elevated groundwater levels are expected to dissipate over time as the water levels within the tailings dams gradually reduce.

As the water level rises at MON02A and MON02B are interpreted to be associated with seepage from the tailings dam Coffey recommends:

- continuation of monitoring of piezometers in the vicinity of the tailings dams;
- review of groundwater levels on an annual basis; and
- should existing trends continue, develop a groundwater control plan and design control measures to address water level rise which could include:
 - augmentation of the existing monitoring network;
 - pumping groundwater from bores introduced in the vicinity of MON02 back to the TSF; and/or
 - installation of trench drains and sumps to collect groundwater and suppress further rise in groundwater levels.

8 LIMITATIONS

8.1 Numerical Simulation

The results reported are specific to the modelled conditions. In the absence of data, the models adopt conditions and parameter values assumed relevant. Should conditions differ from those adopted in the assessments made, results may vary significantly.

The results reported are subject to the uncertainty inherent in numerical modelling. The numerical models are necessarily simplifications of the real system and rely on calibration to data of unknown precision to produce predictive results. The results are estimates only and may differ from future observations.

9 CONCLUSIONS

9.1 Groundwater Impacts due to Open Pit Mining

The Mine Site Model predicted groundwater drawdown due to open pit mining and dewatering to generally remain within ML 1535. Groundwater inflows to the open pit range between approximately 500 m³/day and 700 m³/day between 2016 and mine closure (i.e. up to approximately 200 ML/year). Peak dewatering flows (groundwater take) may exceed that value (by up to 40 ML/year) during major campaigns of horizontal drain (bore) installation in the open pit or vertical dewatering bore commissioning. This would result in maximum groundwater inflows of 228 ML/year within the fractured rock groundwater system and 24 ML/year within the alluvial groundwater system. There is a minor difference between the dry and inundated lake scenarios resulting from very low rates of seepage over the extensive lake area for the lake full scenario.

Pit dewatering water quality is expected to be similar to historical conditions. Groundwater quality within ML 1535 is expected to be similar to historical conditions.

9.2 Impacts on Lake Cowal due to Open Pit Mining

Modelling results suggest negligible impact on Lake Cowal and the associated groundwater system due to the open pit, pit dewatering and groundwater extraction from ML 1535 saline groundwater supply borefield.

9.3 Groundwater Quality Impacts due to Potential Seepage from the Tailings Storage Facilities

The mean vertical leakage from both TSF dams is predicted to be collectively approximately 400 m³/day during the mine life. Conservative assessment of potential impacts to groundwater quality due to seepage from the TSF suggest that after 100 years the potential for groundwater quality changes due to seepage from the TSF stored water will extend a distance of up to approximately 2 km from the TSF walls. However, the movement of some solutes (such as cyanide) will be impeded by sorption and geochemical processes, and their extent of transport within groundwater is likely to be significantly less.

Long-term (post-mine closure) groundwater conditions indicate that solutes associated with potential seepage from the TSF would flow towards, and ultimately terminate within the final pit void. As a result, analytes associated with potential seepage from the TSF are expected to remain within groundwaters between the TSFs and the final void over the long-term.

10 RECOMMENDATIONS

10.1 Data and Monitoring

Coffey recommend:

- Continued groundwater monitoring to validate the predictive modelling, particularly in the vicinity of the open pit, TSF and ML 1535 saline groundwater supply borefield (when in use).
- Continued monitoring of groundwater salinity in the Bland Creek Paleochannel Borefield to assess potential saline migration.
- A final pit void water balance post-mine closure be conducted to assess long-term water levels in the pit void and the potential impact on groundwater quality in the immediate vicinity of the pit void.

11 REFERENCES

- Allison, J.D., and Allison, T.L. (2005). Partition Coefficients for Metals in Surface Water, Soil and Waste. EPA/600/R-05/074, July 2005. U.S. Environmental Protection Agency Office of Research and Development Washington, DC 20460.
- Australian and New Zealand Environmental Conservation Council and Agricultural and Agricultural Resources Management Council of Australia and New Zealand (2000). Australian and New Zealand Guidelines for Fresh and Marina Water Quality.
- Australian and New Zealand Environmental Conservation Council (1995). National Water Quality Management Strategy Guidelines for Groundwater in Australia.
- Australian Natural Resources Atlas (2009). Land Use - Lachlan River Basin 1995/1997. Department of Sustainability, Environment, Water, Population and Communities, Data updated 25 May 2009.
- Barnett, B., Townley, L.R., Post, V., Evans, R.E., Hunt, R.J., Peeters, L., Richardson, S., Werner, A.D., Knapton, A. and Boronkay, A. (2012), Australian Groundwater Modelling Guidelines, Waterlines Report, National Water Commission, Canberra.
- Barrick Australia Limited (2010). Saline Groundwater Assessment – Cowra Aquifer, Cowal Gold Mine, West Wyalong, NSW, Final Report, Project No. BARR010, October 2010.
- Burden, R.J. and Kidd, C.H. (1987). The Environmental Fate of Cyanide in Gold Mine Process Tailings, Proceedings of Annual Conference. Australasian Institute of Mining and Metallurgy, Nelson, New Zealand.
- Carrara, E., Weaver, T., Cartwright, I. and Cresswell, R. (2004). ^{14}C and ^{36}Cl as indicators of groundwater flow, Bland Catchment, NSW *In: Wanty, R., and R. I. Seal (eds), Proceedings of the Eleventh International Symposium on Water-Rock Interaction WRI-11, 27 June - 2 July 2004, Saratoga Springs, NY. Leiden, The Netherlands: A.A. Balkema: 377-381.*
- Coffey Services Australia Pty Ltd (1995a). Lake Cowal Project Hydrogeological Modelling and Dewatering Study. Report No. G255/28-AF, 3 April 1995.
- Coffey Services Australia Pty Ltd (1995b). Outside Borefield Feasibility Study for Lake Cowal Project, Report No. G255/24-AJ, February 1995.
- Coffey Services Australia Pty Ltd (1995c). Lake Cowal Project Hydrogeological Study of Tailings Dams Area. Report No. G255/21-AD, February 1995.
- Coffey Services Australia Pty Ltd (1995d). Lake Cowal Project – Hydrogeological Modelling and Dewatering Study. Report No. G255/28-AF, April 1995.
- Coffey Services Australia Pty Ltd (1997). Groundwater Studies – Hydrogeological Assessment.
- Coffey Services Australia Pty Ltd (2006). Cowal Gold Mine, Groundwater Supply Modelling Study, Model Calibration. Report No. S21910/2AK, 15 September 2006.
- Coffey Services Australia Pty Ltd (2008). Cowal Gold Mine, Pit Dewatering Assessment. Report No. GEOTLCOV21910AC-AC, 5 August 2008.
- Coffey Services Australia Pty Ltd (2009a). Cowal Gold Mine, Groundwater Level Investigation. Report No. GEOTLCOV21910AF-AB, 26 March 2009.
- Coffey Services Australia Pty Ltd (2009b). Cowal Gold Mine, Groundwater Monitoring Review 2008. Report No. GEOTLCOV21910AE-AB, 24 February 2009.
- Coffey Services Australia Pty Ltd (2011). Cowal Gold Mine Augmentation Project, Hydrogeological Assessment. Report No. GEOTLCOV21910AJ-AL, 16 March 2011.

- Coffey Services Australia Pty Ltd (2012). Cowal Gold Mine, Groundwater Monitoring Review 2011. Report No. GEOTLCOV21910AV-AC, 5 September 2012.
- Coffey Services Australia Pty Ltd (2013). Cowal Gold Mine, Extension Modification Hydrogeological Assessment. Report No. GEOTLCOV21910AW-AI, 9 September 2013.
- Coffey Services Australia Pty Ltd (2016). Cowal Gold Operations, Groundwater Monitoring Review 2015. Report No. GEOTLCOV21910BF-AE, 6 August 2016.
- Department of Land and Water Conservation (1997). The NSW State Groundwater Policy Framework Document.
- Department of Land and Water Conservation (1998). The NSW State Groundwater Quality Protection Policy.
- Department of Land and Water Conservation (2002). The NSW Groundwater Dependent Ecosystem Policy.
- Doorenbos, J. and Pruitt, W.O. (1977). Guidelines for predicting crop water requirements, FAO-ONU, Rome, Irrigation and Drainage Paper no. 24 (rev.), 144 pp.
- Groundwater Consulting Services Pty Ltd (2006). Jemalong Water Supply Borefield Installation and Testing, Cowal Gold Project, West Wyalong, New South Wales. Report BARR003. August.
- Groundwater Consulting Services Pty Ltd (2008). Saline Groundwater Assessment – Alluvial Aquifer E42 Modification, Cowal Gold Mine, West Wyalong, New South Wales. Report BARR010, July 2008.
- Hawkes, G.E. (1998). Hydrogeology of the Proposed Lake Cowal Gold Mine, NSW. Unpublished MSc Thesis, University of Technology, Sydney.
- Hydro Engineering & Consulting Pty Ltd (2016). Cowal Gold Operations Mine Life Modification – Hydrological Assessment. Prepared for Evolution Mining Pty Limited.
- Johnson, A.I. (1967). Specific Yield – Compilation of specific yield for various materials. USGS Water-Supply Paper 1662-D, 74p.
- Knight Piesold Pty Ltd (1994). Lake Cowal Project Laboratory Testing of Tailings, Reference 216/2, June 1994.
- North Limited (1998). Cowal Gold Project, Environmental Impact Statement. North Gold WA Limited, 13 March 1998.
- Northern Resource Consultants (2016). Groundwater Investigation - Progressive Groundwater Level Rise in MON02A and MON02B. March 2016.
- NSW Office of Water (2012). NSW Aquifer Interference Policy.
- Schmidt, J.W., L. Simovic and E. Shannon (1981). Development Studies for Suitable Technologies for the Removal of Cyanide and Heavy Metals from Gold Milling Effluents. Proceedings of the 36th Industrial Waste Conference, Purdue University, pp. 831-846.
- SNC-Lavalin Australia (2003). Cowal Gold Project Geotechnical Investigation Report. Report 334371-0000-4GRA-0001 prepared for Barrick Gold of Australia. December.
- Williams, B.G. (1993). The Shallow Groundwater Hydrology of the Jemalong – Wyldes Plains Irrigation Districts, NSW Department of Agriculture, March.

URS Australia Pty Limited (2005). Cowal Northern Tailings Storage Facility – Floor Permeability, Reference 51755-005.

URS Australia Pty Limited (2006). Cowal Southern Tailings Storage Facility – Floor Permeability, Reference 43167213.



Important information about your **Coffey** Report

As a client of Coffey you should know that site subsurface conditions cause more construction problems than any other factor. These notes have been prepared by Coffey to help you interpret and understand the limitations of your report.

Your report is based on project specific criteria

Your report has been developed on the basis of your unique project specific requirements as understood by Coffey and applies only to the site investigated. Project criteria typically include the general nature of the project; its size and configuration; the location of any structures on the site; other site improvements; the presence of underground utilities; and the additional risk imposed by scope-of-service limitations imposed by the client. Your report should not be used if there are any changes to the project without first asking Coffey to assess how factors that changed subsequent to the date of the report affect the report's recommendations. Coffey cannot accept responsibility for problems that may occur due to changed factors if they are not consulted.

Subsurface conditions can change

Subsurface conditions are created by natural processes and the activity of man. For example, water levels can vary with time, fill may be placed on a site and pollutants may migrate with time. Because a report is based on conditions which existed at the time of subsurface exploration, decisions should not be based on a report whose adequacy may have been affected by time. Consult Coffey to be advised how time may have impacted on the project.

Interpretation of factual data

Site assessment identifies actual subsurface conditions only at those points where samples are taken and when they are taken. Data derived from literature and external data source review, sampling and subsequent laboratory testing are interpreted by geologists, engineers or scientists to provide an opinion about overall site conditions, their likely impact on the proposed development and recommended actions. Actual conditions may differ from those inferred to exist, because no professional, no matter how qualified, can reveal what is hidden by earth, rock and time. The actual interface between materials may be far more gradual or abrupt than assumed based on the facts obtained. Nothing can be done to change the actual site conditions which exist, but steps can be taken to reduce the impact of unexpected conditions. For this reason, owners should retain the services of Coffey through the development stage, to identify variances, conduct additional tests if required, and recommend solutions to problems encountered on site.

Your report will only give preliminary recommendations

Your report is based on the assumption that the site conditions as revealed through selective point sampling are indicative of actual conditions throughout an area. This assumption cannot be substantiated until project implementation has commenced and therefore your report recommendations can only be regarded as preliminary. Only Coffey, who prepared the report, is fully familiar with the background information needed to assess whether or not the report's recommendations are valid and whether or not changes should be considered as the project develops. If another party undertakes the implementation of the recommendations of this report there is a risk that the report will be misinterpreted and Coffey cannot be held responsible for such misinterpretation.

Your report is prepared for specific purposes and persons

To avoid misuse of the information contained in your report it is recommended that you confer with Coffey before passing your report on to another party who may not be familiar with the background and the purpose of the report. Your report should not be applied to any project other than that originally specified at the time the report was issued.

Interpretation by other design professionals

Costly problems can occur when other design professionals develop their plans based on misinterpretations of a report. To help avoid misinterpretations, retain Coffey to work with other project design professionals who are affected by the report. Have Coffey explain the report implications to design professionals affected by them and then review plans and specifications produced to see how they incorporate the report findings.



Important information about your **Coffey Report**

Data should not be separated from the report*

The report as a whole presents the findings of the site assessment and the report should not be copied in part or altered in any way. Logs, figures, drawings, etc. are customarily included in our reports and are developed by scientists, engineers or geologists based on their interpretation of field logs (assembled by field personnel) and laboratory evaluation of field samples. These logs etc. should not under any circumstances be redrawn for inclusion in other documents or separated from the report in any way.

Geoenvironmental concerns are not at issue

Your report is not likely to relate any findings, conclusions, or recommendations about the potential for hazardous materials existing at the site unless specifically required to do so by the client. Specialist equipment, techniques, and personnel are used to perform a geoenvironmental assessment. Contamination can create major health, safety and environmental risks. If you have no information about the potential for your site to be contaminated or create an environmental hazard, you are advised to contact Coffey for information relating to geoenvironmental issues.

Rely on Coffey for additional assistance

Coffey is familiar with a variety of techniques and approaches that can be used to help reduce risks for all parties to a project, from design to construction. It is common that not all approaches will be necessarily dealt with in your site assessment report due to concepts proposed at that time. As the project progresses through design towards construction, speak with Coffey to develop alternative approaches to problems that may be of genuine benefit both in time and cost.

Responsibility

Reporting relies on interpretation of factual information based on judgement and opinion and has a level of uncertainty attached to it, which is far less exact than the design disciplines. This has often resulted in claims being lodged against consultants, which are unfounded. To help prevent this problem, a number of clauses have been developed for use in contracts, reports and other documents. Responsibility clauses do not transfer appropriate liabilities from Coffey to other parties but are included to identify where Coffey's responsibilities begin and end. Their use is intended to help all parties involved to recognise their individual responsibilities. Read all documents from Coffey closely and do not hesitate to ask any questions you may have.

* For further information on this aspect reference should be made to "Guidelines for the Provision of Geotechnical information in Construction Contracts" published by the Institution of Engineers Australia, National headquarters, Canberra, 1987.

Appendix A - Figures

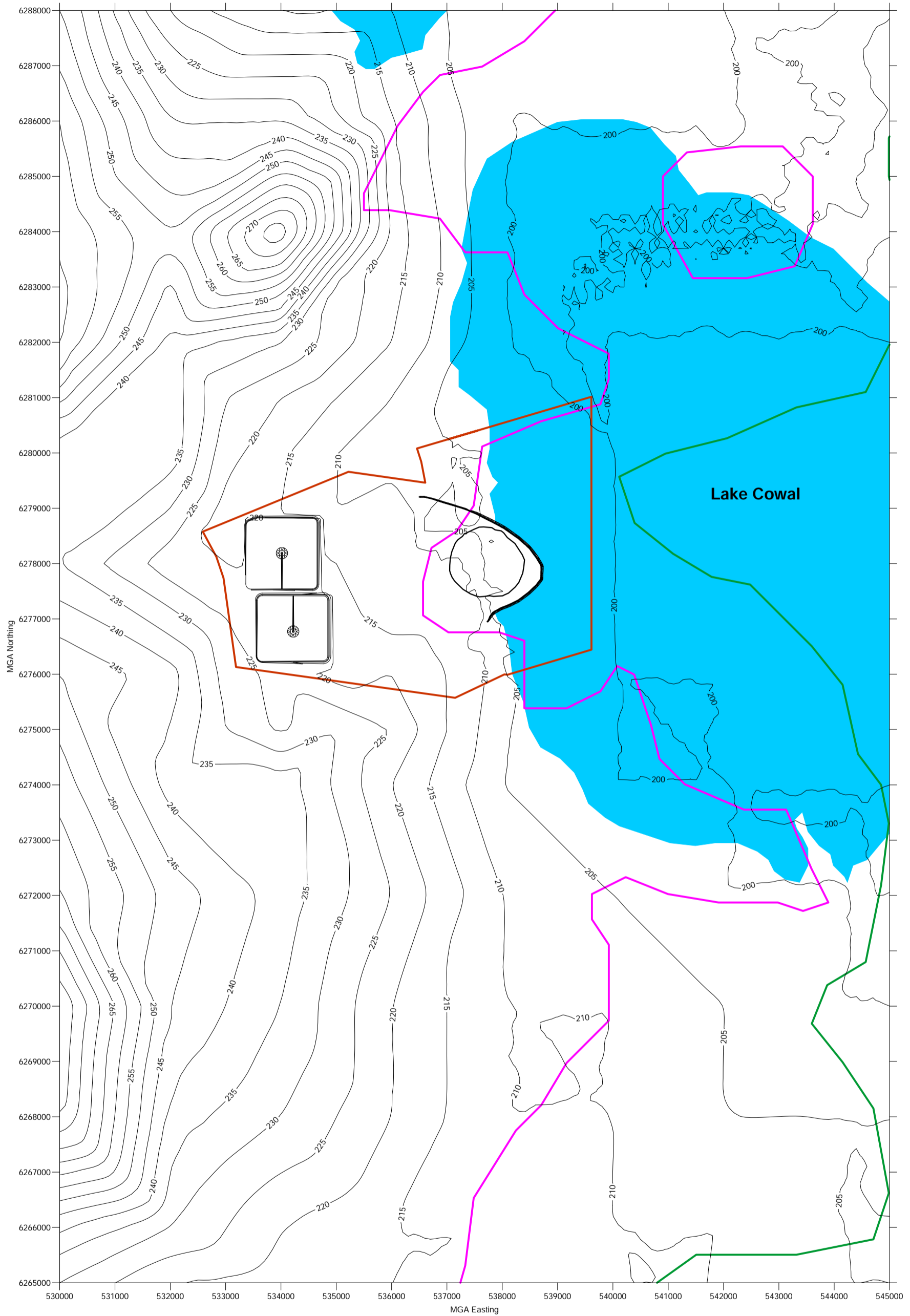

KEY

- Contour of Ground Surface (mAHd)
- Interpreted extent of Lachlan Formation
- Interpreted extent of Cowra Formation
- Mining Lease

| | |
|---------------|-------------|
| drawn | SE |
| approved | RJB |
| date | 09 NOV 2016 |
| scale | 1:70,000 |
| original size | A3 |



| | | |
|-------------|---|------------------------------|
| client: | EVOLUTION MINING (COWAL) PTY LTD | |
| project: | COWAL GOLD OPERATIONS MINE LIFE MODIFICATION HYDROGEOLOGICAL ASSESSMENT | |
| title: | SURFACE CONTOURS FOR MODEL-ADOPTED GROUND LEVEL | |
| project no: | GEOTLCOV21910BG | figure no: FIGURE A-1 |

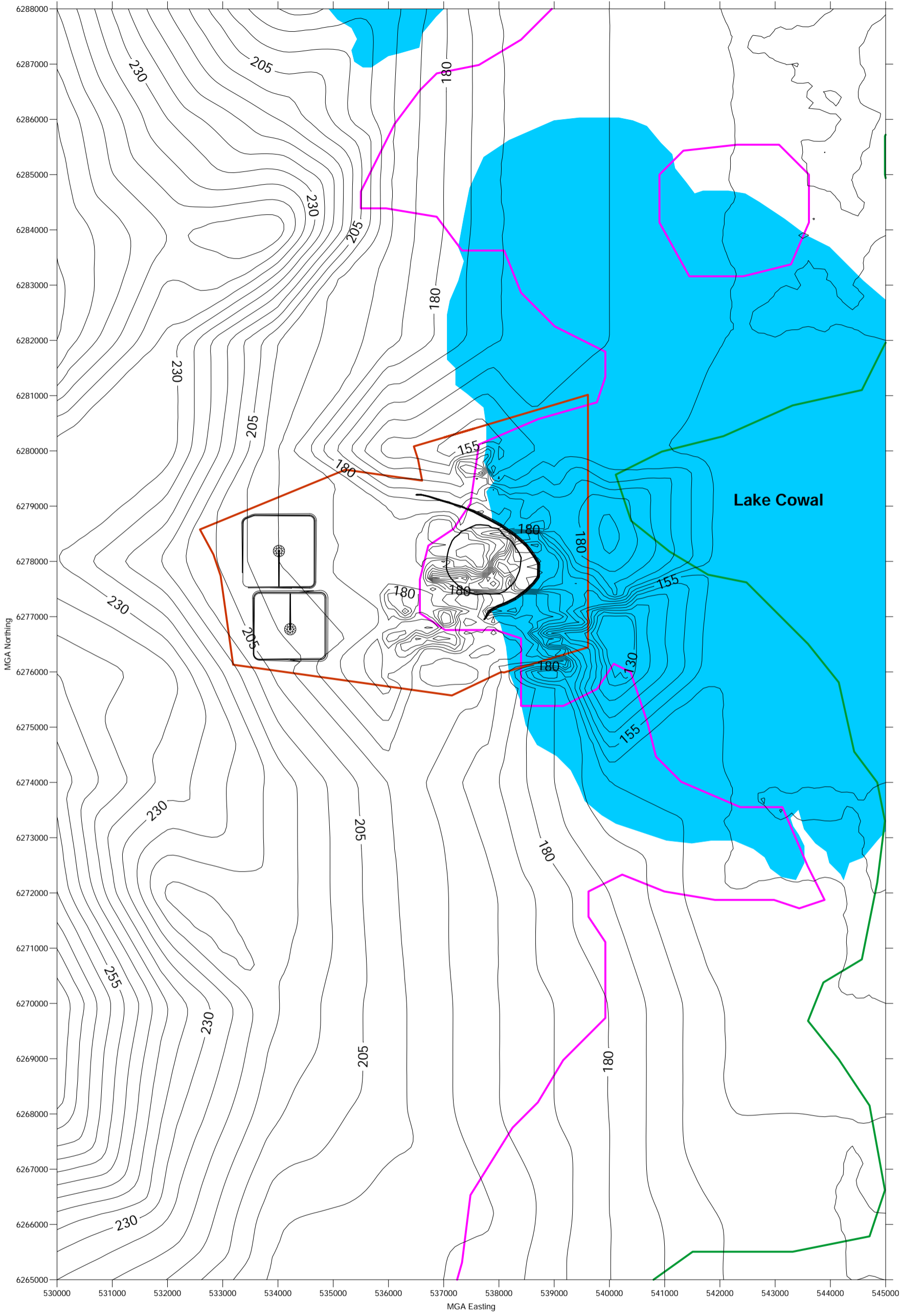

- KEY
- Contour of Ground Surface (mAHD)
 - Interpreted extent of Lachlan Formation
 - Interpreted extent of Cowra Formation
 - Mining Lease





| | |
|---------------|-------------|
| drawn | SE |
| approved | RJB |
| date | 09 NOV 2016 |
| scale | 1:70,000 |
| original size | A3 |

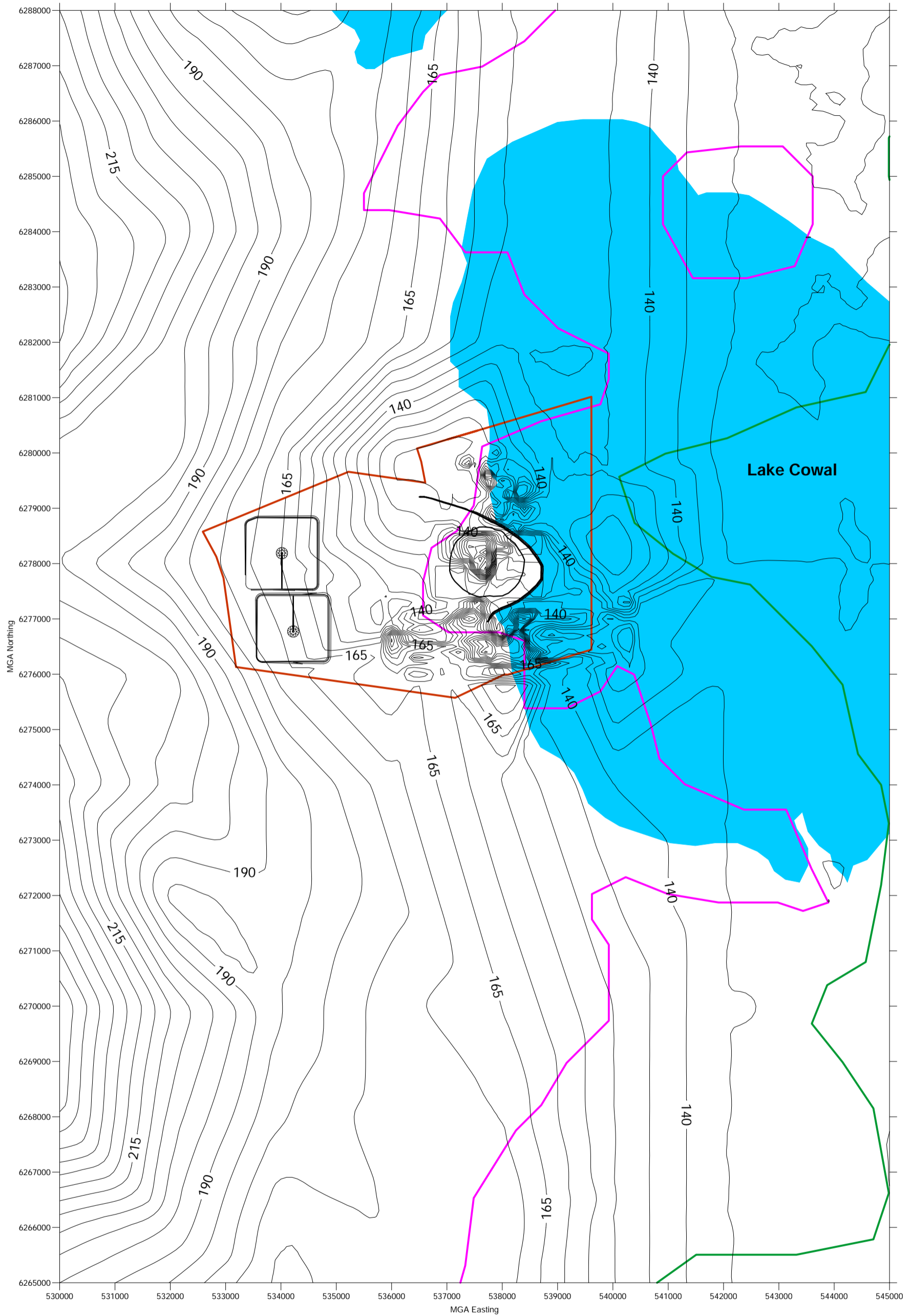

| | | |
|-------------|---|------------------------------|
| client: | EVOLUTION MINING (COWAL) PTY LTD | |
| project: | COWAL GOLD OPERATIONS MINE LIFE MODIFICATION HYDROGEOLOGICAL ASSESSMENT | |
| title: | SURFACE CONTOURS FOR MODEL-ADOPTED BASE OF TRANSPORTED UNIT | |
| project no: | GEOTLCOV21910BG | figure no: FIGURE A-2 |



KEY

-  Contour of Ground Surface (mAHD)
-  Interpreted extent of Lachlan Formation
-  Interpreted extent of Cowra Formation
-  Mining Lease





| | |
|---------------|-------------|
| drawn | SE |
| approved | RJB |
| date | 09 NOV 2016 |
| scale | 1:70,000 |
| original size | A3 |

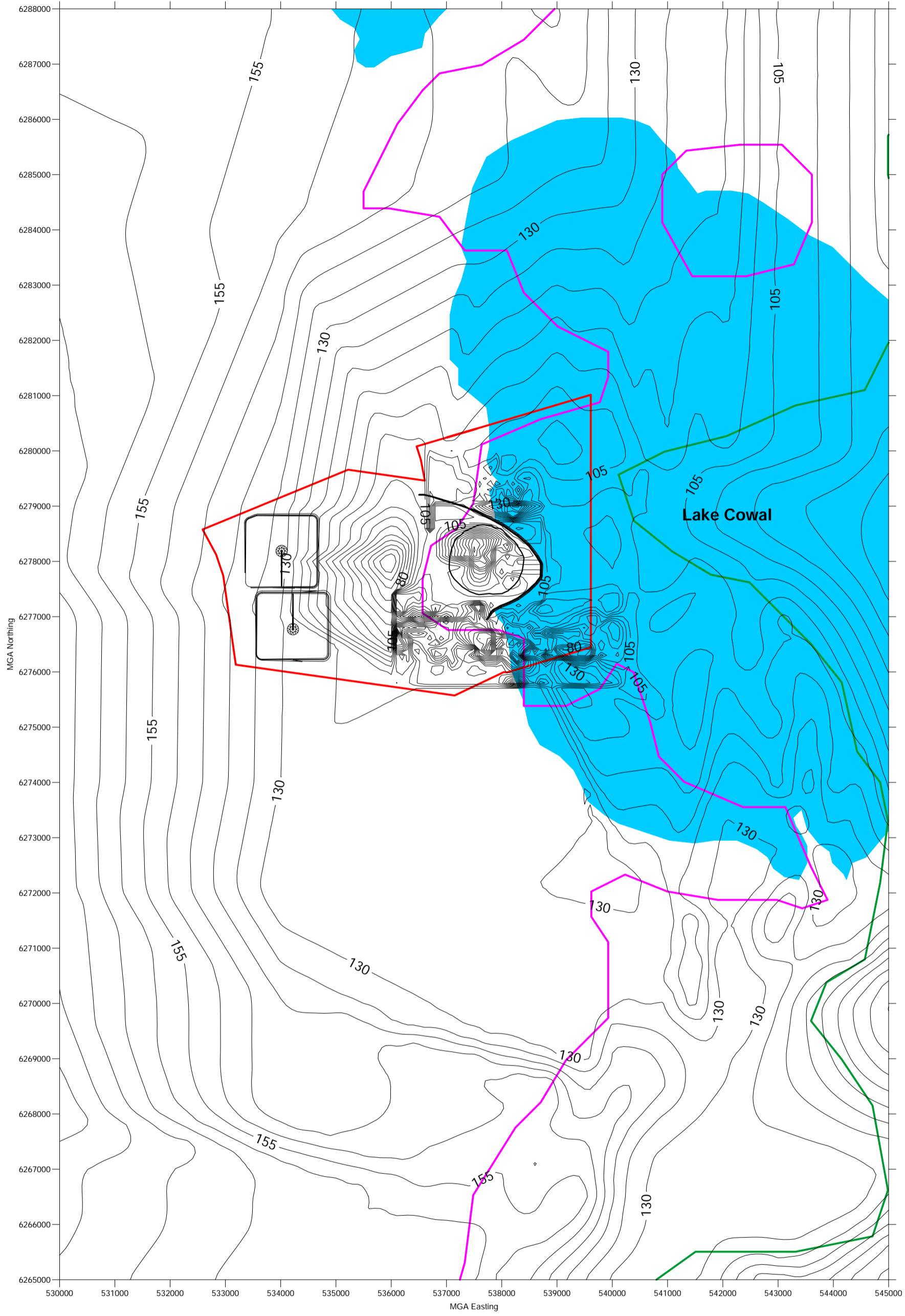

| | | |
|-------------|---|------------------------------|
| client: | EVOLUTION MINING (COWAL) PTY LTD | |
| project: | COWAL GOLD OPERATIONS MINE LIFE MODIFICATION HYDROGEOLOGICAL ASSESSMENT | |
| title: | SURFACE CONTOURS FOR MODEL-ADOPTED BASE OF SAPROLITE UNIT | |
| project no: | GEOTLCOV21910BG | figure no: FIGURE A-3 |



KEY

-  Contour of Ground Surface (mAHD)
-  Interpreted extent of Lachlan Formation
-  Interpreted extent of Cowra Formation
-  Mining Lease

| | |
|---------------|-------------|
| drawn | SE |
| approved | RJB |
| date | 09 NOV 2016 |
| scale | 1:70,000 |
| original size | A3 |



| | | |
|-------------|---|------------------------------|
| client: | EVOLUTION MINING (COWAL) PTY LTD | |
| project: | COWAL GOLD OPERATIONS MINE LIFE MODIFICATION HYDROGEOLOGICAL ASSESSMENT | |
| title: | SURFACE CONTOURS FOR MODEL-ADOPTED BASE OF SAPROCK UNIT | |
| project no: | GEOTLCOV21910BG | figure no: FIGURE A-4 |

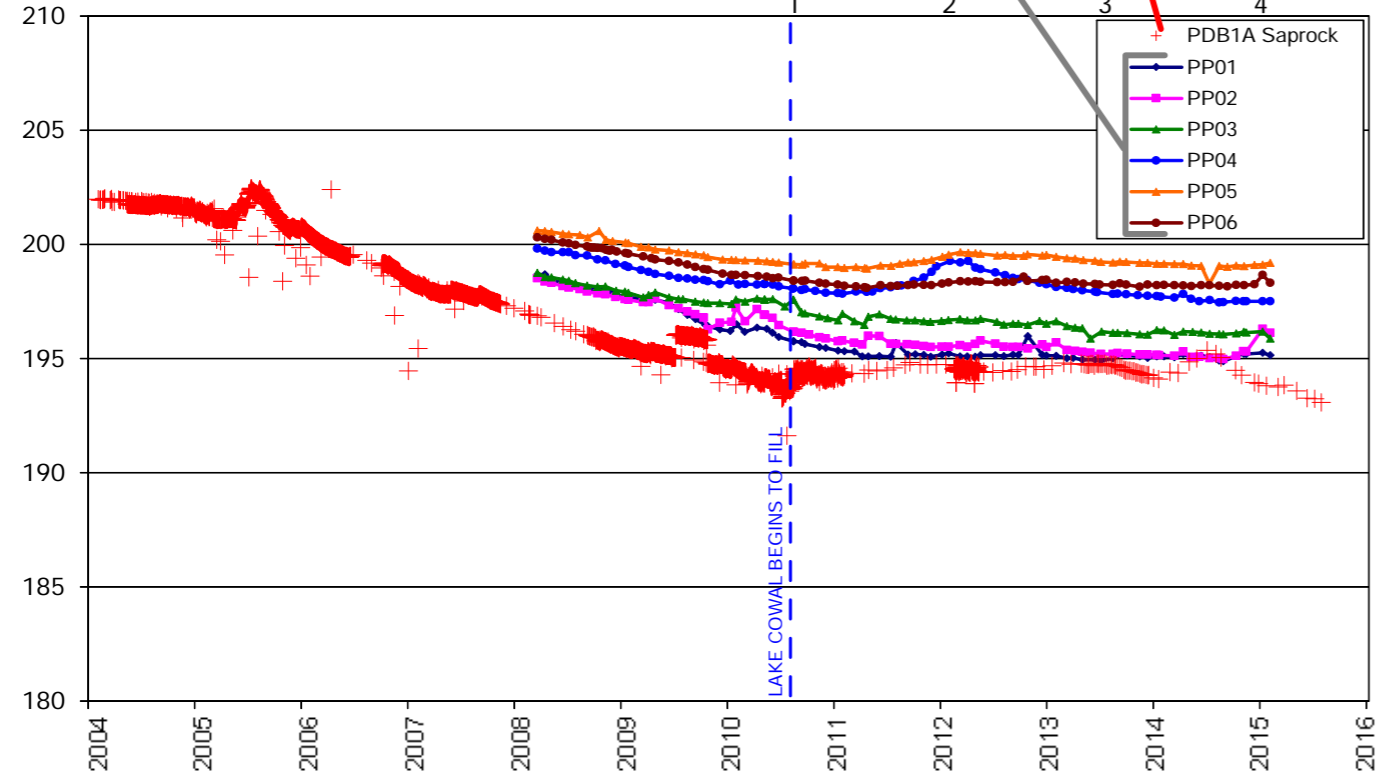
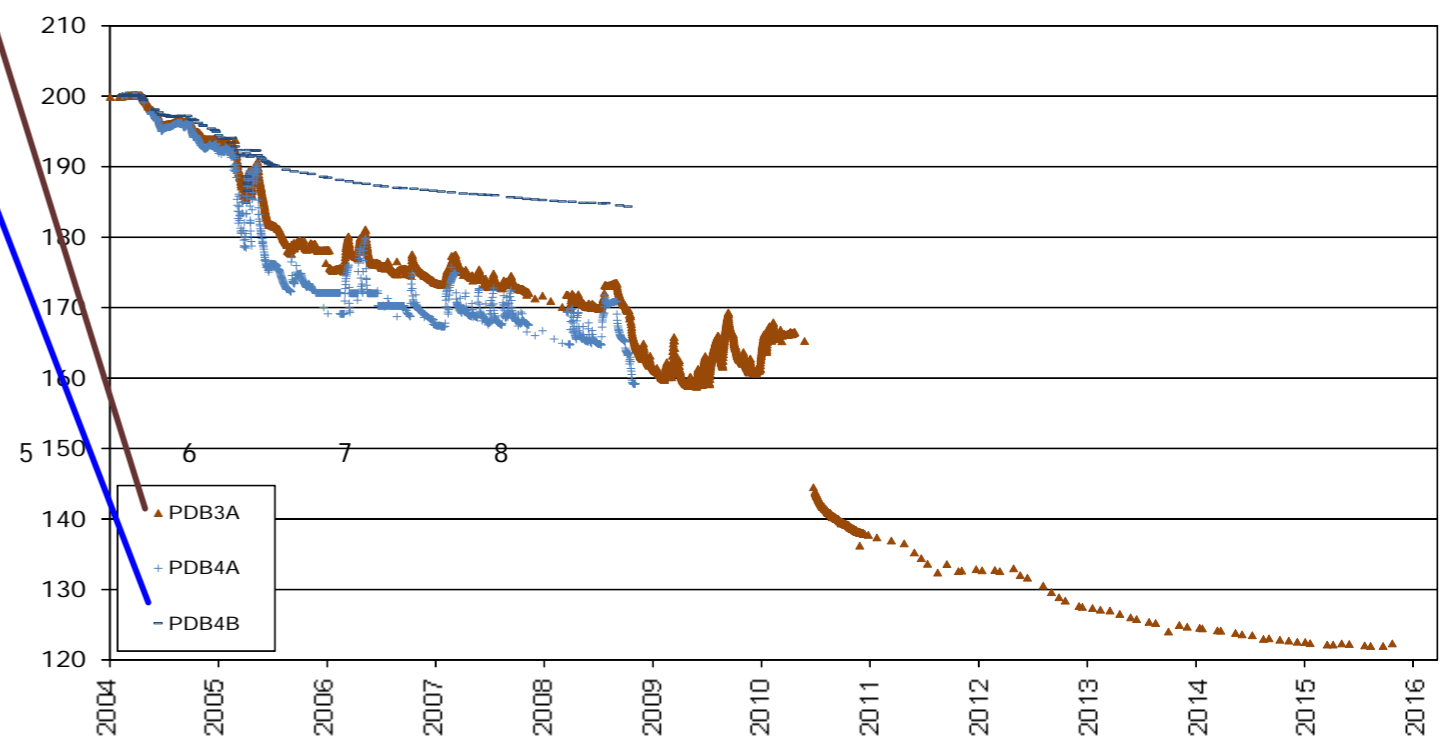
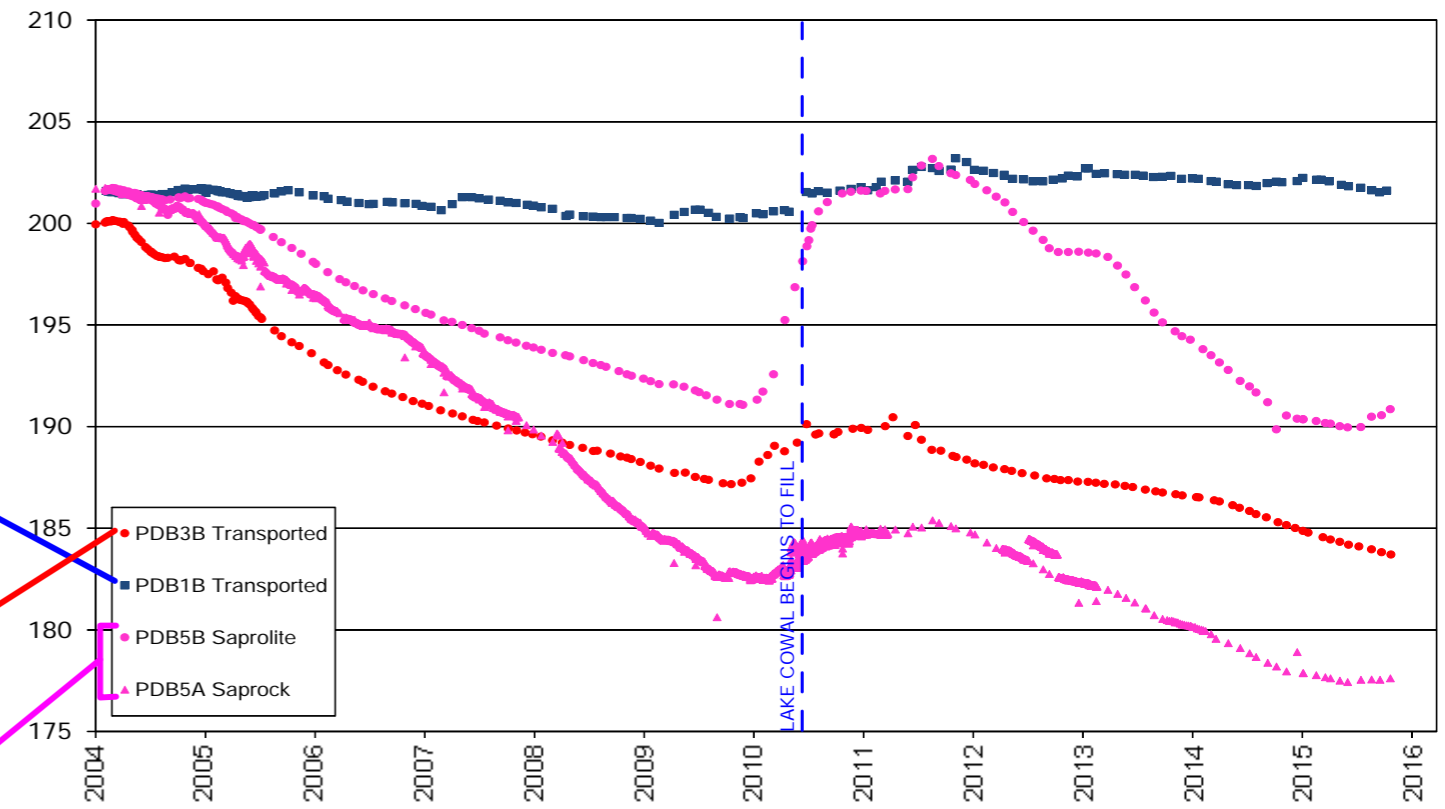
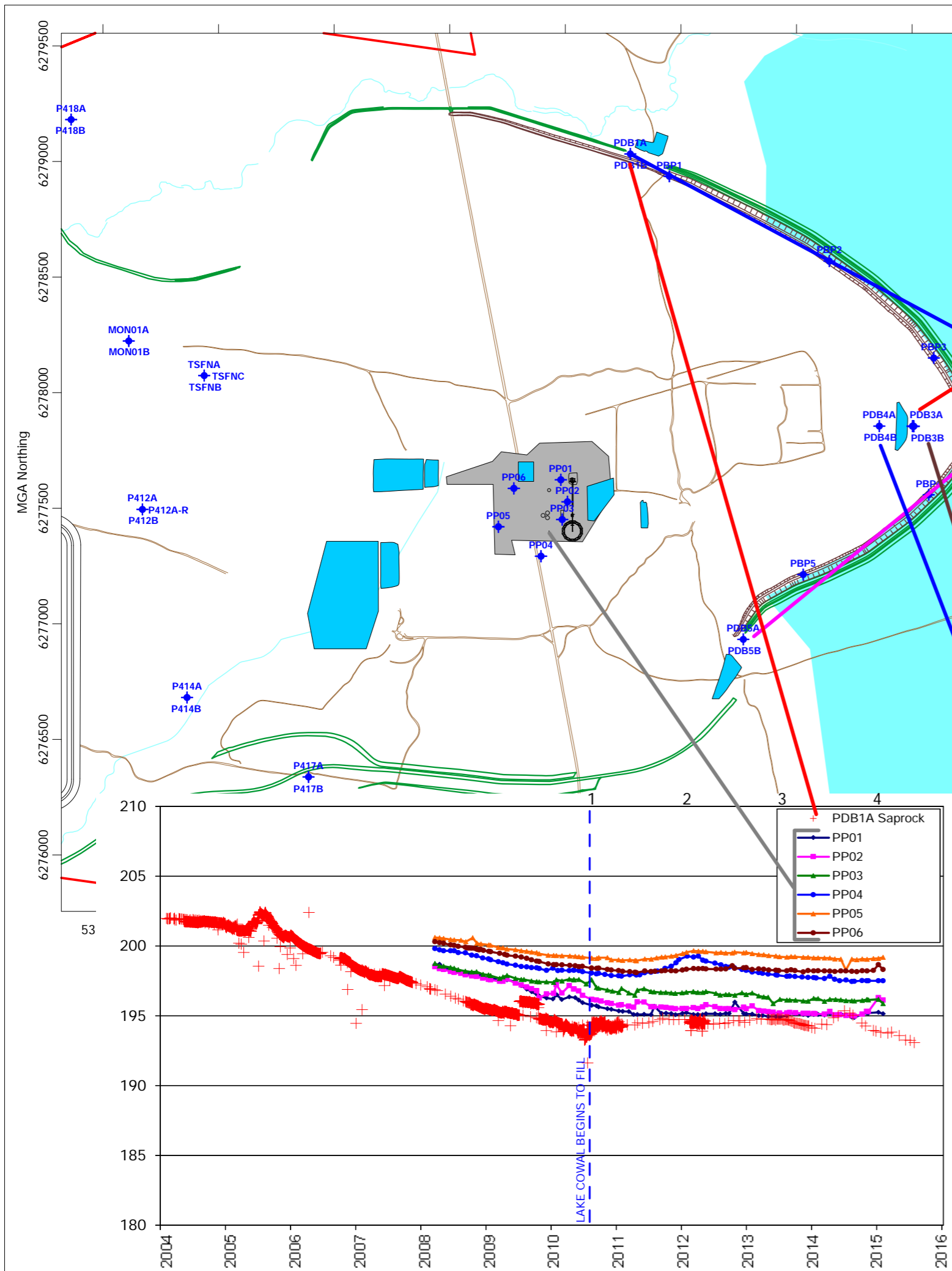

| | |
|---------------|-------------|
| drawn | SE |
| approved | RJB |
| date | 09 NOV 2016 |
| scale | 1:20,000 |
| original size | A3 |



| | | |
|-------------|---|------------------------------|
| client: | EVOLUTION MINING (COWAL) PTY LTD | |
| project: | COWAL GOLD OPERATIONS MINE LIFE MODIFICATION HYDROGEOLOGICAL ASSESSMENT | |
| title: | GROUNDWATER RESPONSE TO LAKE COWAL | |
| project no: | GEOTLCOV21910BG | figure no: FIGURE A-5 |

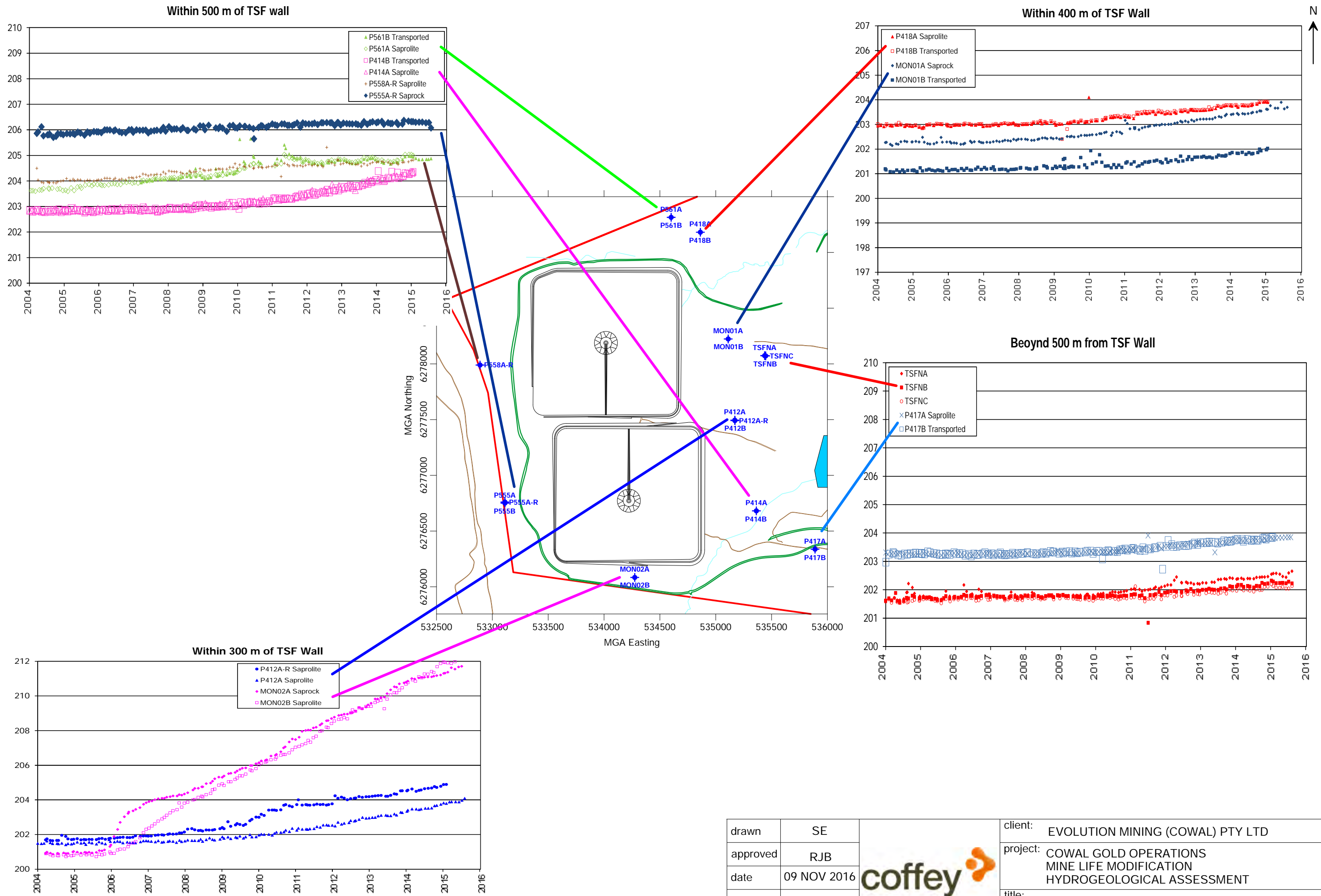

| | |
|---------------|-------------|
| drawn | SE |
| approved | RJB |
| date | 09 NOV 2016 |
| scale | 1:30,000 |
| original size | A3 |



| | | |
|-------------|---|------------------------------|
| client: | EVOLUTION MINING (COWAL) PTY LTD | |
| project: | COWAL GOLD OPERATIONS MINE LIFE MODIFICATION HYDROGEOLOGICAL ASSESSMENT | |
| title: | GROUNDWATER RESPONSE TO TSF | |
| project no: | GEOTLCOV21910BG | figure no: FIGURE A-6 |

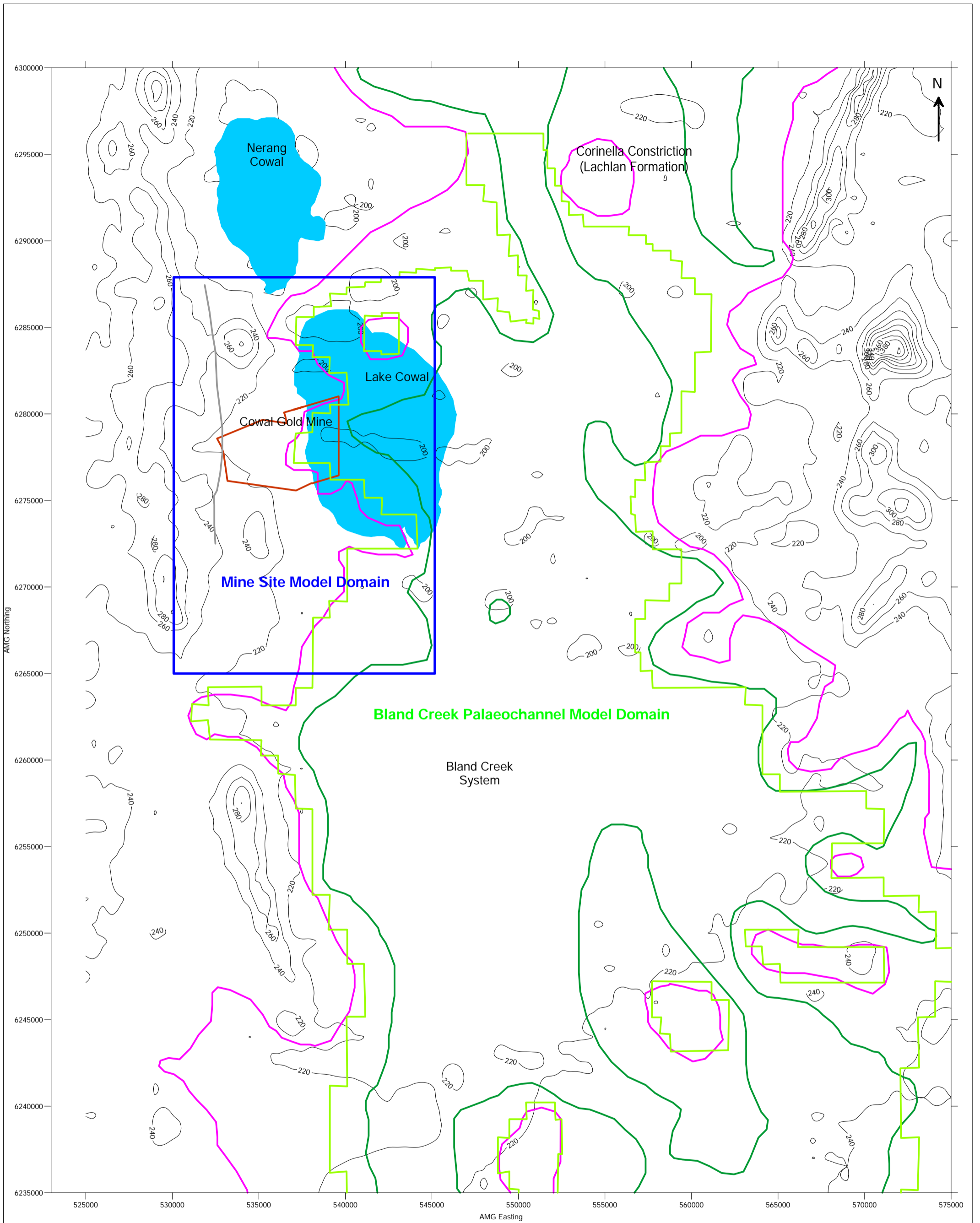

KEY

- Interpreted extent of Lachlan Formation
- Interpreted extent of Cowra Formation
- Gilmore Suture (not to full extent)
- Topographical Contour (mAHD)
- Cowal Mine Lease Boundary

| | |
|---------------|-------------|
| drawn | SE |
| approved | RJB |
| date | 09 NOV 2016 |
| scale | 1:200,000 |
| original size | A3 |



| | | |
|-------------|---|------------------------------|
| client: | EVOLUTION MINING (COWAL) PTY LTD | |
| project: | COWAL GOLD OPERATIONS MINE LIFE MODIFICATION HYDROGEOLOGICAL ASSESSMENT | |
| title: | MODEL DOMAINS | |
| project no: | GEOTLCOV21910BG | figure no: FIGURE A-7 |

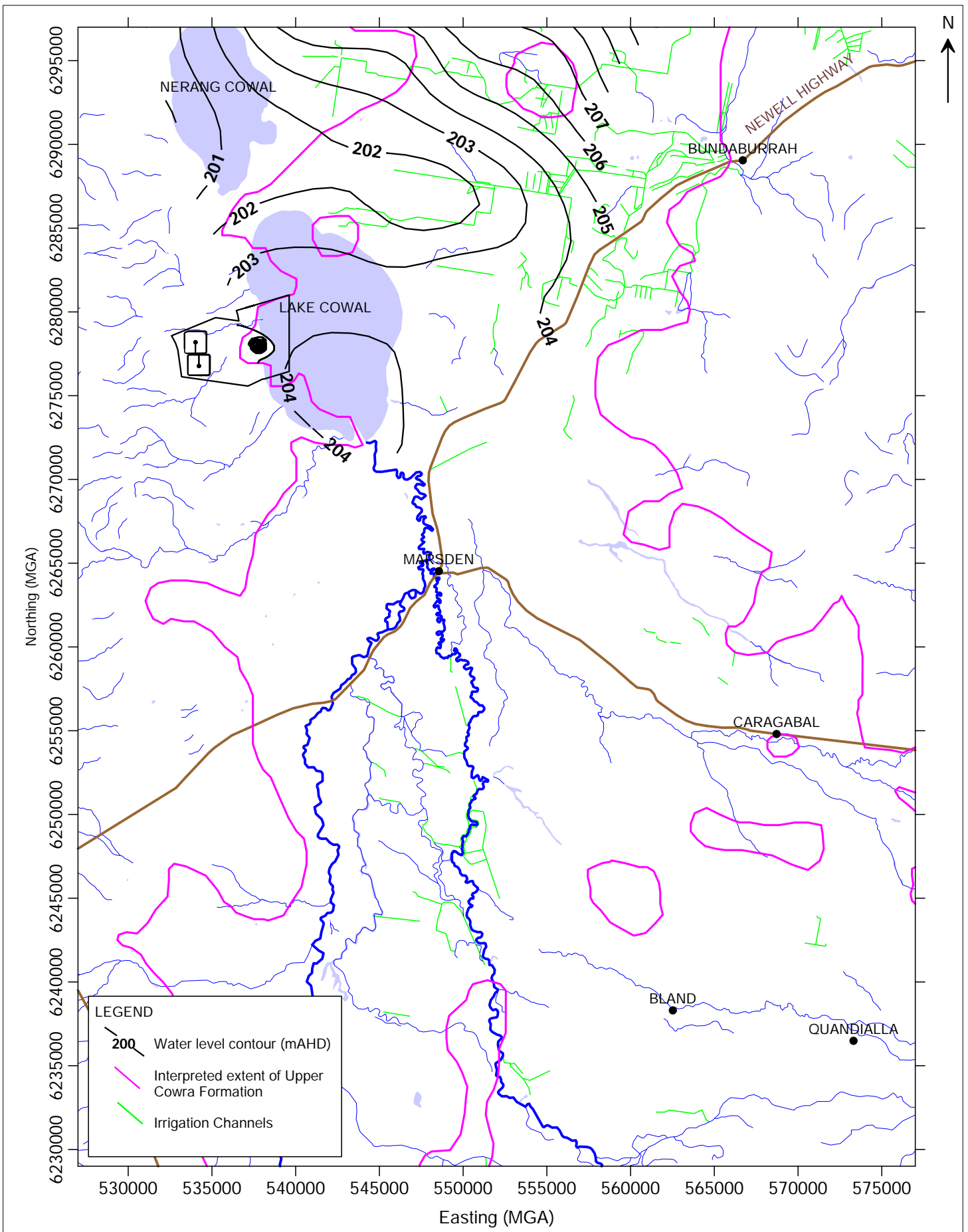

| | | | | | | |
|---------------|-------------|---|-------------|---|------------|-------------------|
| drawn | PT/SE |  | client: | EVOLUTION MINING (COWAL) PTY LTD | | |
| approved | RJB | | project: | COWAL GOLD OPERATIONS MINE LIFE MODIFICATION HYDROGEOLOGICAL ASSESSMENT | | |
| date | 09 NOV 2016 | | title: | WATER LEVELS IN THE UPPER COWRA FORMATION FOR DECEMBER 1997 | | |
| scale | 1:300,000 | | project no: | GEOTLCOV21910BG | figure no: | FIGURE A-8 |
| original size | A4 | | | | | |

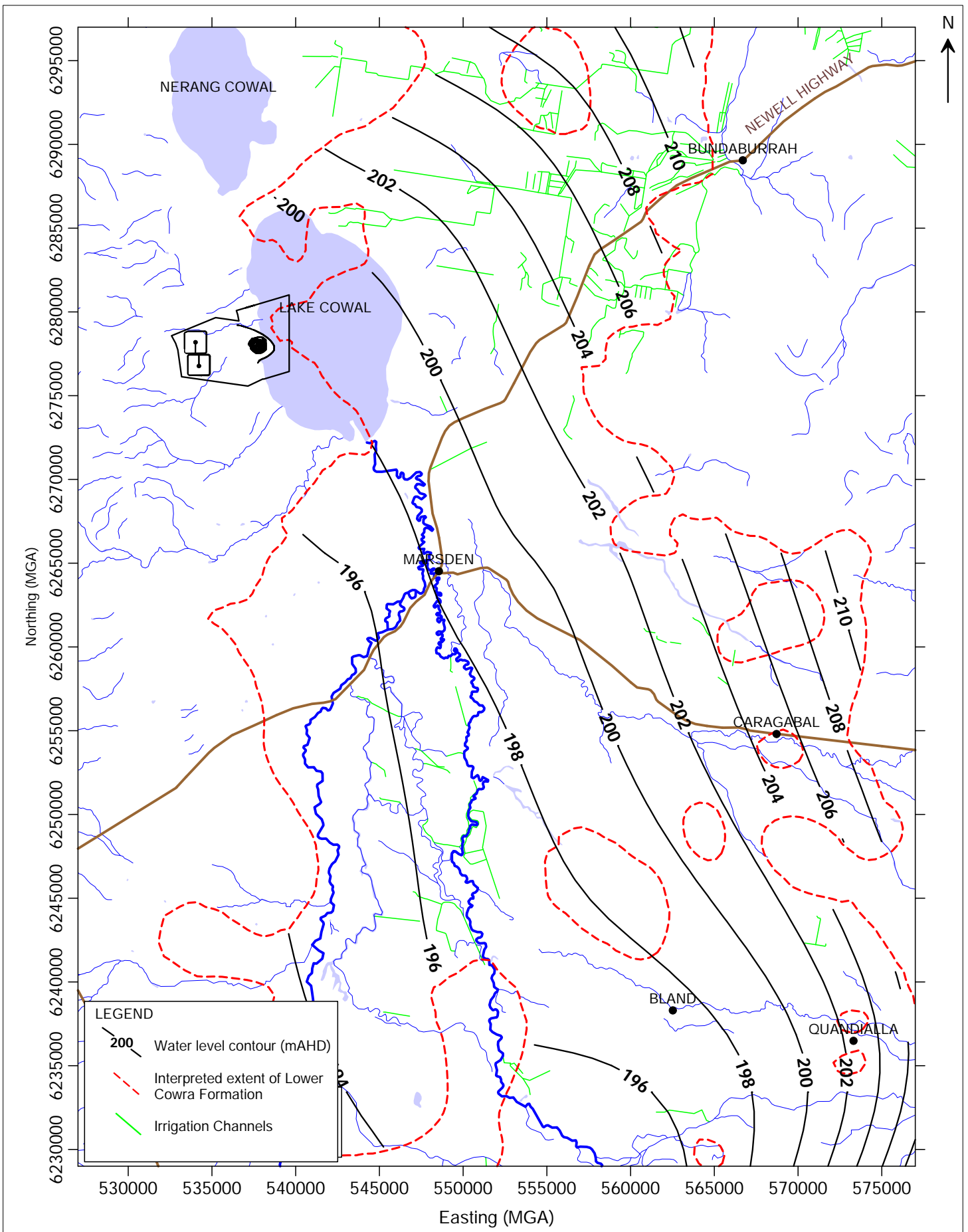

| | | | | | | |
|---------------|-------------|---|-------------|---|------------|-------------------|
| drawn | PT/SE |  | client: | EVOLUTION MINING (COWAL) PTY LTD | | |
| approved | RJB | | project: | COWAL GOLD OPERATIONS MINE LIFE MODIFICATION HYDROGEOLOGICAL ASSESSMENT | | |
| date | 09 NOV 2016 | | title: | WATER LEVELS IN THE LOWER COWRA FORMATION FOR DECEMBER 1997 | | |
| scale | 1:300,000 | | project no: | GEOTLCOV21910BG | figure no: | FIGURE A-9 |
| original size | A4 | | | | | |

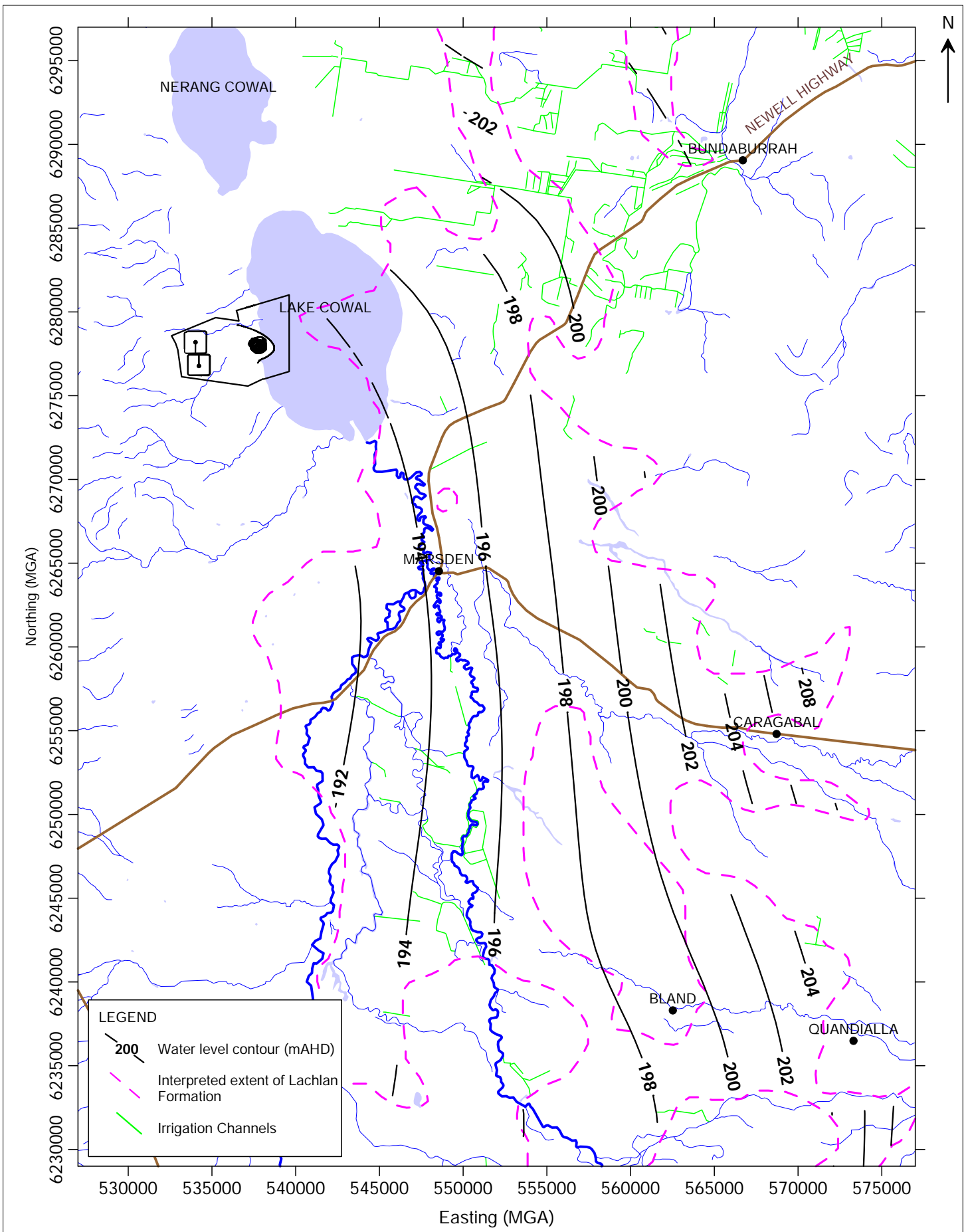

| | | | | | | |
|---------------|-------------|---|-------------|---|------------|--------------------|
| drawn | PT/SE |  | client: | EVOLUTION MINING (COWAL) PTY LTD | | |
| approved | RJB | | project: | COWAL GOLD OPERATIONS MINE LIFE MODIFICATION HYDROGEOLOGICAL ASSESSMENT | | |
| date | 09 NOV 2016 | | title: | WATER LEVELS IN THE LACHLAN FORMATION FOR DECEMBER 1997 | | |
| scale | 1:300,000 | | project no: | GEOTLCOV21910BG | figure no: | FIGURE A-10 |
| original size | A4 | | | | | |

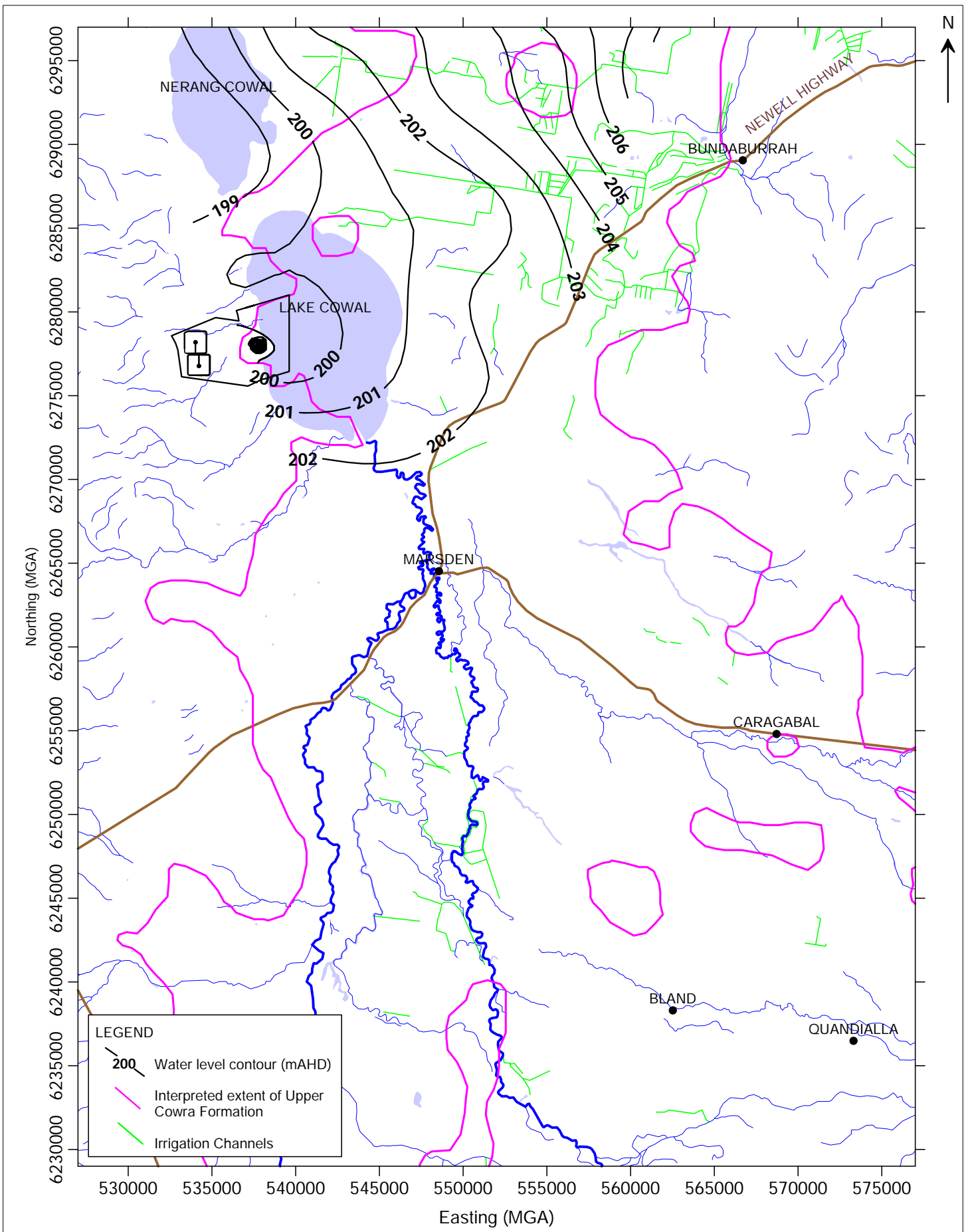

| | | | | | | |
|---------------|-------------|---|-------------|---|------------|--------------------|
| drawn | PT/SE |  | client: | EVOLUTION MINING (COWAL) PTY LTD | | |
| approved | RJB | | project: | COWAL GOLD OPERATIONS MINE LIFE MODIFICATION HYDROGEOLOGICAL ASSESSMENT | | |
| date | 09 NOV 2016 | | title: | WATER LEVELS IN THE UPPER COWRA FORMATION FOR SEPTEMBER 2006 | | |
| scale | 1:300,000 | | project no: | GEOTLCOV21910BG | figure no: | FIGURE A-11 |
| original size | A4 | | | | | |

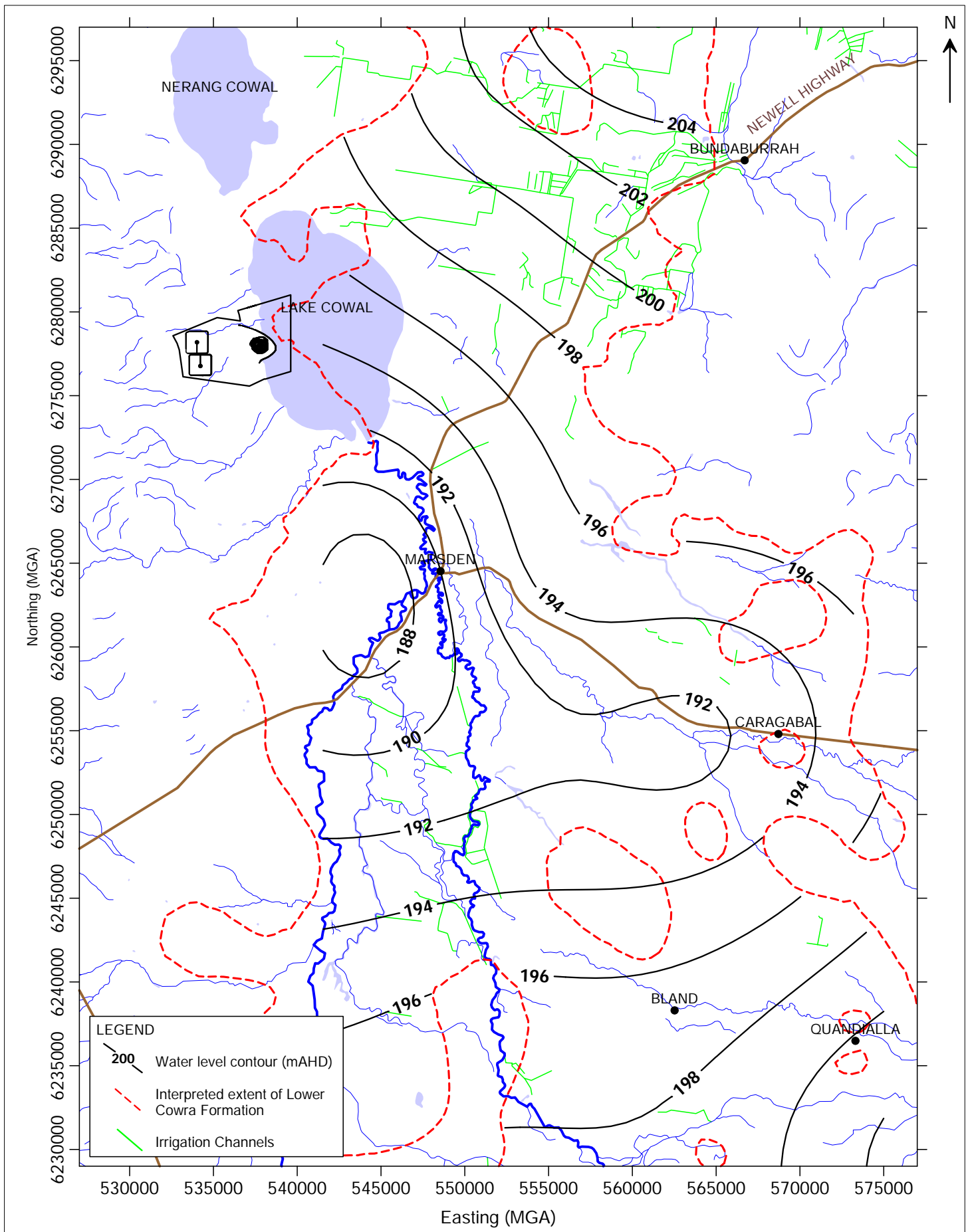

| | | | | | | |
|---------------|-------------|--|-------------|---|------------|--------------------|
| drawn | PT/SE | | client: | EVOLUTION MINING (COWAL) PTY LTD | | |
| approved | RJB | | project: | COWAL GOLD OPERATIONS MINE LIFE MODIFICATION HYDROGEOLOGICAL ASSESSMENT | | |
| date | 09 NOV 2016 | | title: | WATER LEVELS IN THE LOWER COWRA FORMATION FOR SEPTEMBER 2006 | | |
| scale | 1:300,000 | | project no: | GEOTLCOV21910BG | figure no: | FIGURE A-12 |
| original size | A4 | | | | | |

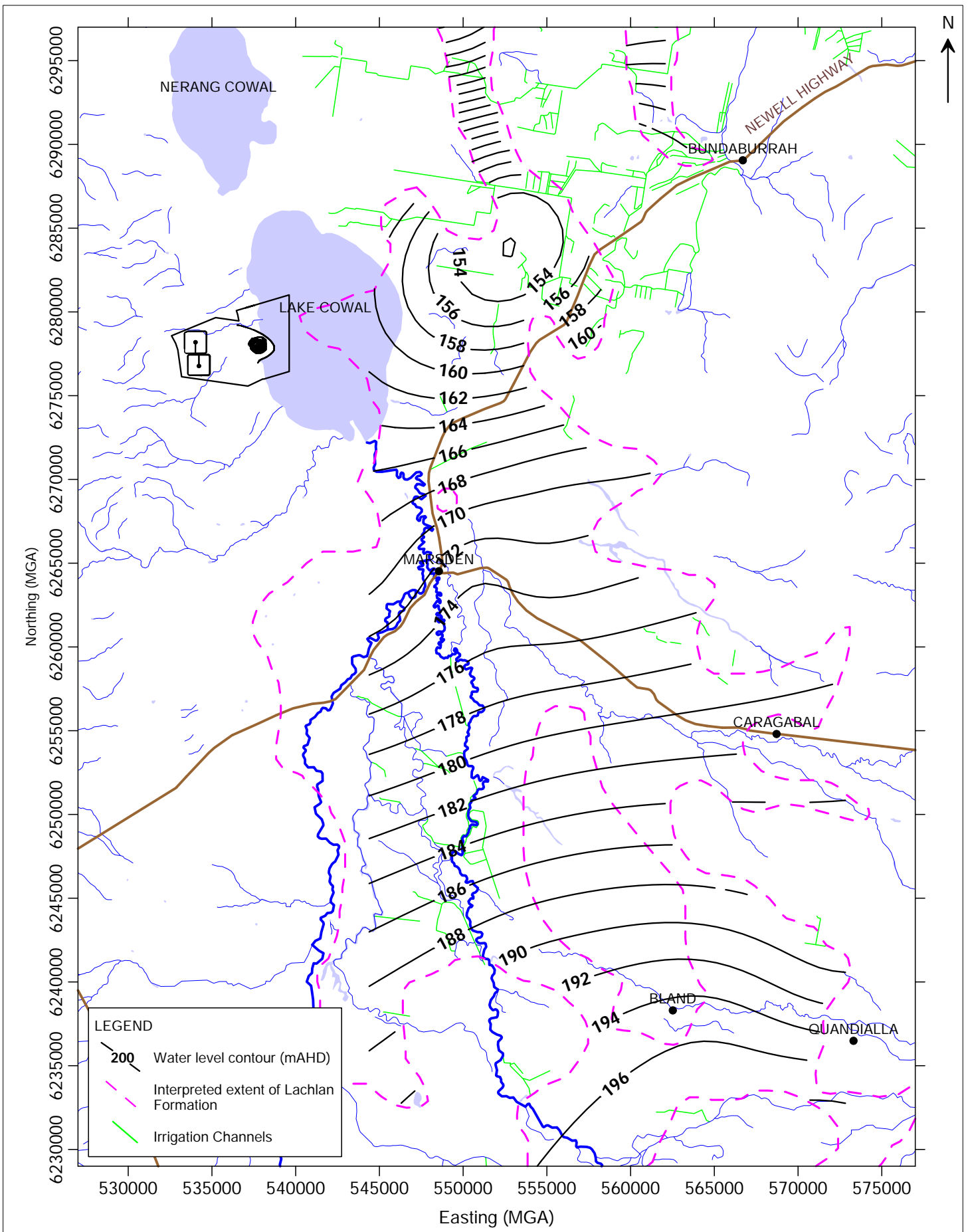

| | | | | | | |
|---------------|-------------|---|-------------|---|------------|--------------------|
| drawn | PT/SE |  A TETRA TECH COMPANY | client: | EVOLUTION MINING (COWAL) PTY LTD | | |
| approved | RJB | | project: | COWAL GOLD OPERATIONS MINE LIFE MODIFICATION HYDROGEOLOGICAL ASSESSMENT | | |
| date | 09 NOV 2016 | | title: | WATER LEVELS IN THE LACHLAN FORMATION FOR SEPTEMBER 2006 | | |
| scale | 1:300,000 | | project no: | GEOTLCOV21910BG | figure no: | FIGURE A-13 |
| original size | A4 | | | | | |

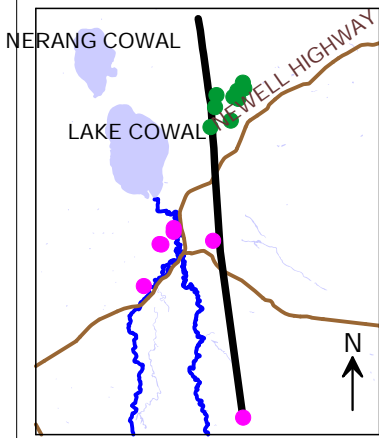
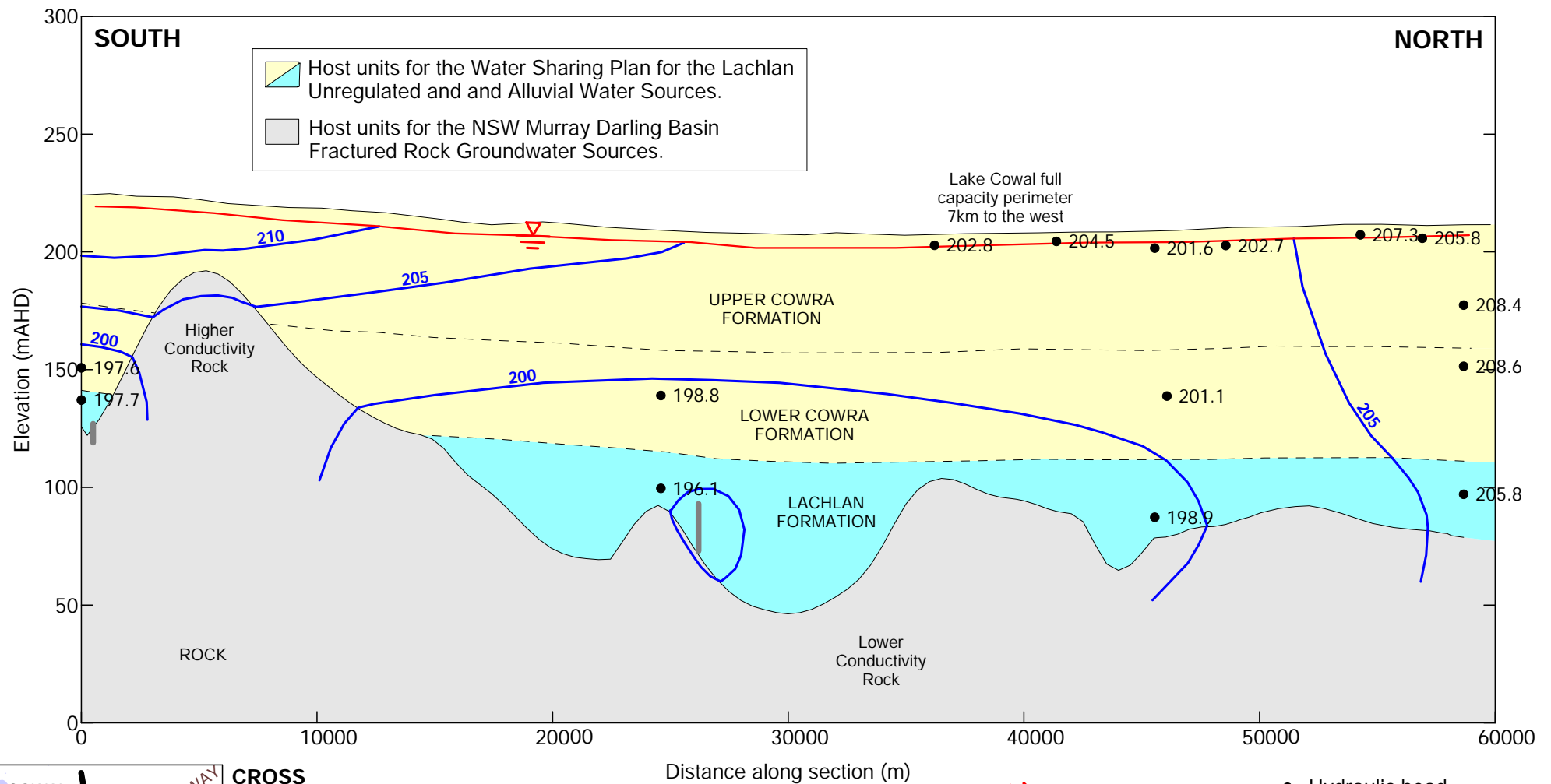

| | |
|---------------|----------------------------|
| drawn | PT/SE |
| approved | RJB |
| date | 09 NOV 2016 |
| scale | H: 1:250,000 V: 1:2,500 |
| original size | A4 |



| | | |
|-------------|---|-------------------------------|
| client: | EVOLUTION MINING (COWAL) PTY LTD | |
| project: | COWAL GOLD OPERATIONS MINE LIFE MODIFICATION HYDROGEOLOGICAL ASSESSMENT | |
| title: | HYDRAULIC HEAD CROSS-SECTION FOR DECEMBER 1997 | |
| project no: | GEOTLCOV21910BG | figure no: FIGURE A-14 |

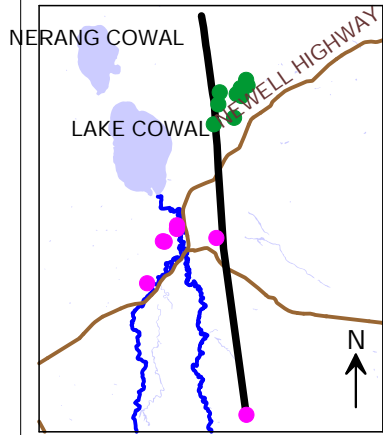
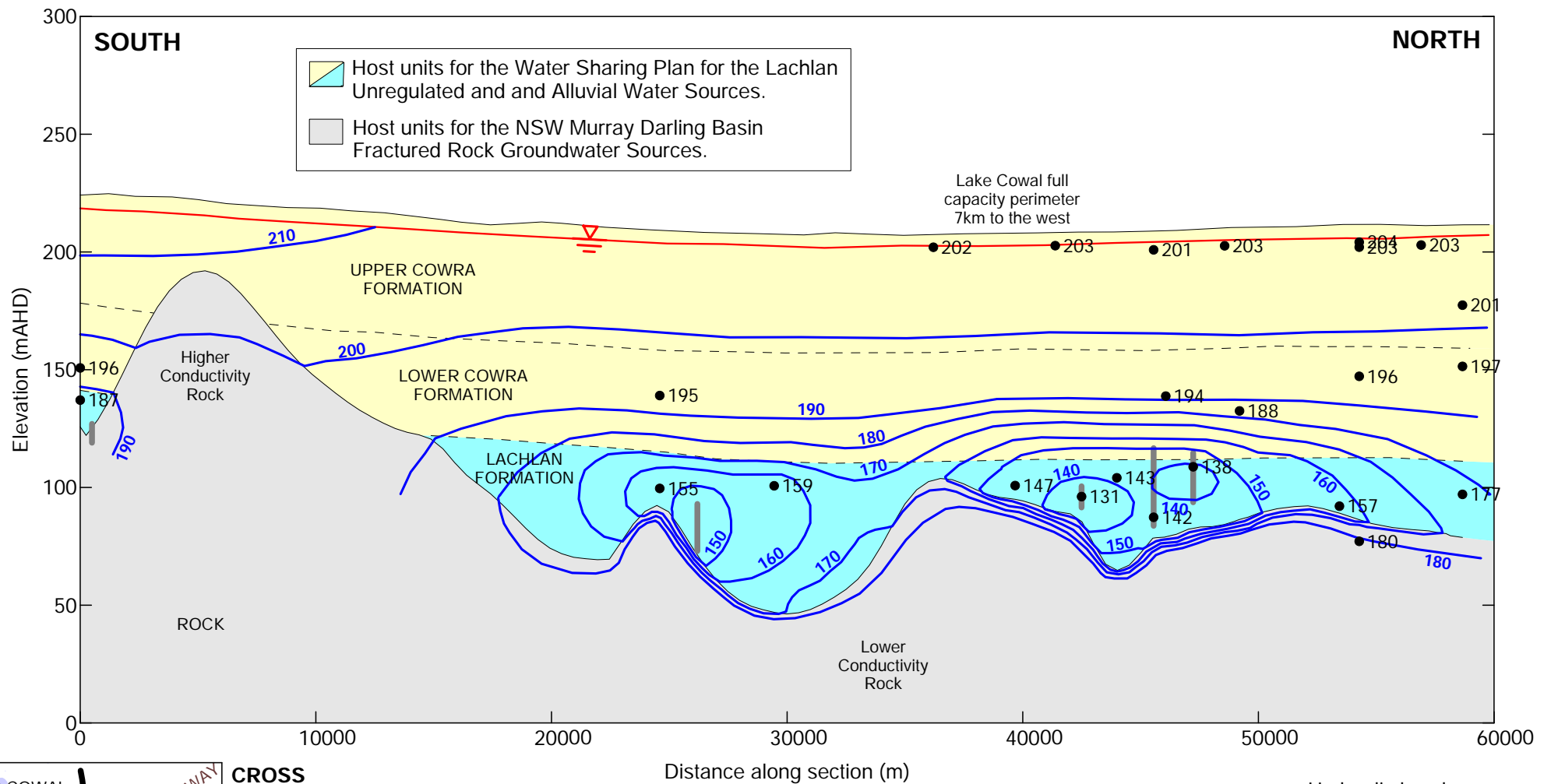

CROSS SECTION LOCATION

- Barrick pumping bore
- Private pumping bore

Vertical to horizontal exaggeration 1:100

- Water Table
- Interpreted hydraulic head (mAHD)
- 195 Hydraulic head measurement (mAHD)
- Pumping bore screen projected onto cross-section

| | |
|---------------|----------------------------|
| drawn | PT/SE |
| approved | RJB |
| date | 09 NOV 2016 |
| scale | H: 1:250,000 V: 1:2,500 |
| original size | A4 |



| | | |
|-------------|---|-------------------------------|
| client: | EVOLUTION MINING (COWAL) PTY LTD | |
| project: | COWAL GOLD OPERATIONS MINE LIFE MODIFICATION HYDROGEOLOGICAL ASSESSMENT | |
| title: | HYDRAULIC HEAD CROSS-SECTION FOR JANUARY 2010 | |
| project no: | GEOTLCOV21910BG | figure no: FIGURE A-15 |

Pit vicinity

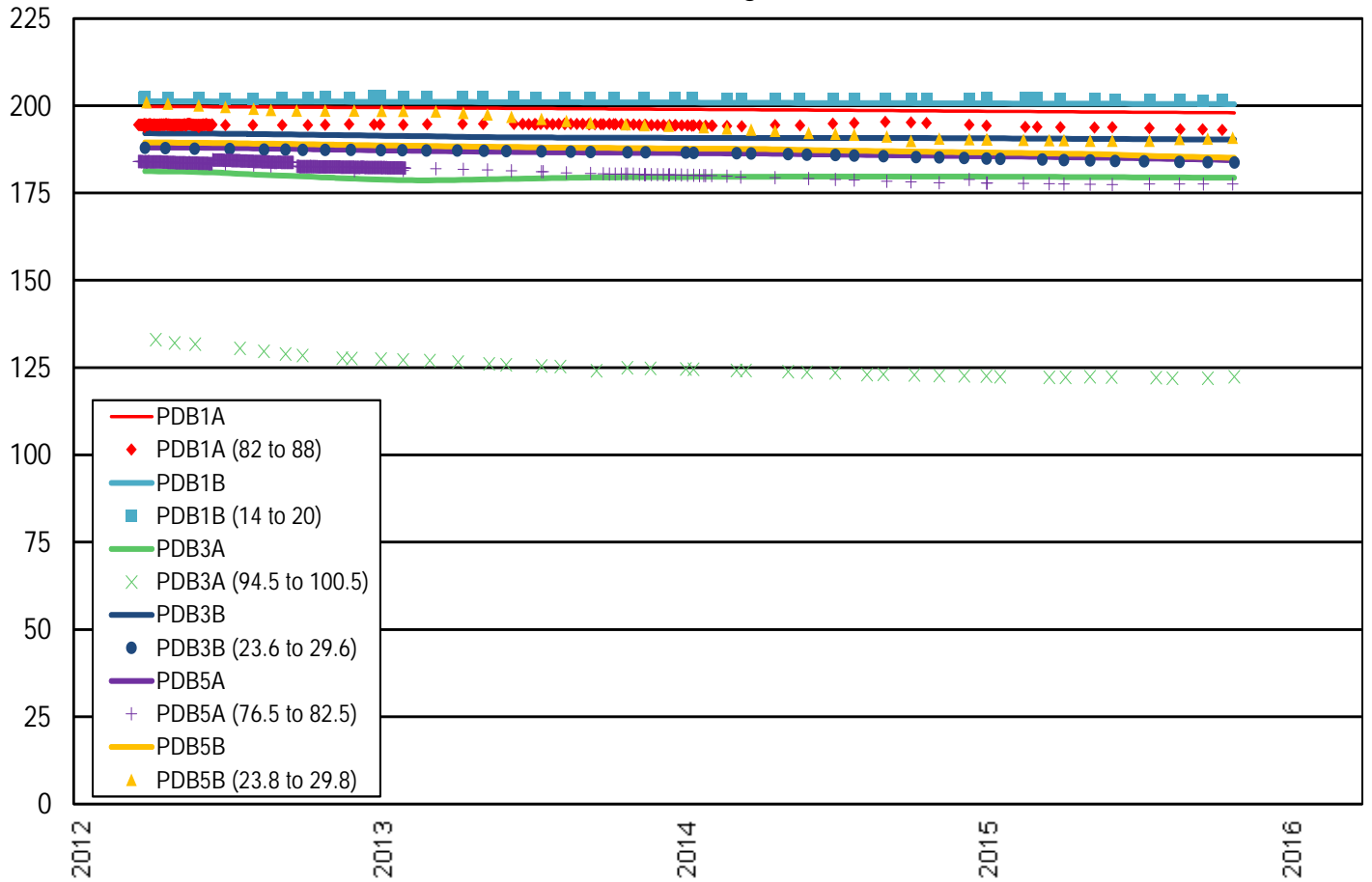

KEY

Solid line - modelled result
 Points - monitoring data
 PDB1A (82-88) - Bore ID
 (screen interval, mbgl)

| | | | | |
|---------------|-------------|--|-------------|---|
| drawn | SE |  <small>A TETRA TECH COMPANY</small> | client: | EVOLUTION MINING (COWAL) PTY LTD |
| approved | RJB | | project: | COWAL GOLD OPERATIONS MINE LIFE MODIFICATION HYDROGEOLOGICAL ASSESSMENT |
| date | 09 NOV 2016 | | title: | CALIBRATION HYDROGRAPHS - PIT AREA |
| scale | As Shown | | project no: | GEOTLCOV21910BG |
| original size | A4 | | figure no: | FIGURE A-16 |

Processing Plant

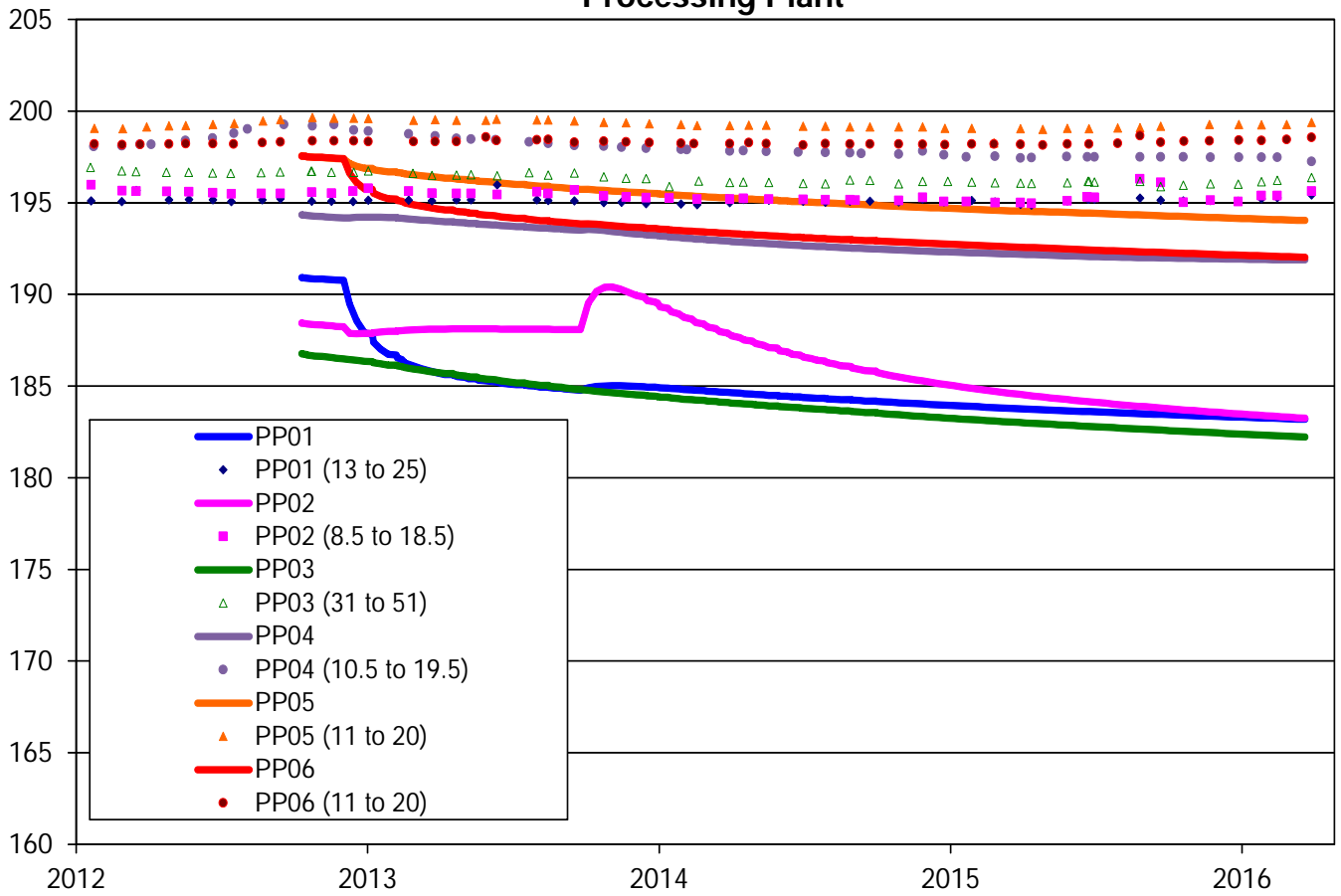

KEY

Solid line - modelled result
 Points - monitoring data
 PDB1A (82-88) - Bore ID
 (screen interval, mbgl)

| | | | | | | |
|---------------|-------------|--|-------------|---|------------|--------------------|
| drawn | SE |  <small>A TETRA TECH COMPANY</small> | client: | EVOLUTION MINING (COWAL) PTY LTD | | |
| approved | RJB | | project: | COWAL GOLD OPERATIONS MINE LIFE MODIFICATION HYDROGEOLOGICAL ASSESSMENT | | |
| date | 09 NOV 2016 | | title: | CALIBRATION HYDROGRAPHS - PROCESSING PLANT AREA | | |
| scale | As Shown | | project no: | GEOTLCOV21910BG | figure no: | FIGURE A-17 |
| original size | A4 | | | | | |

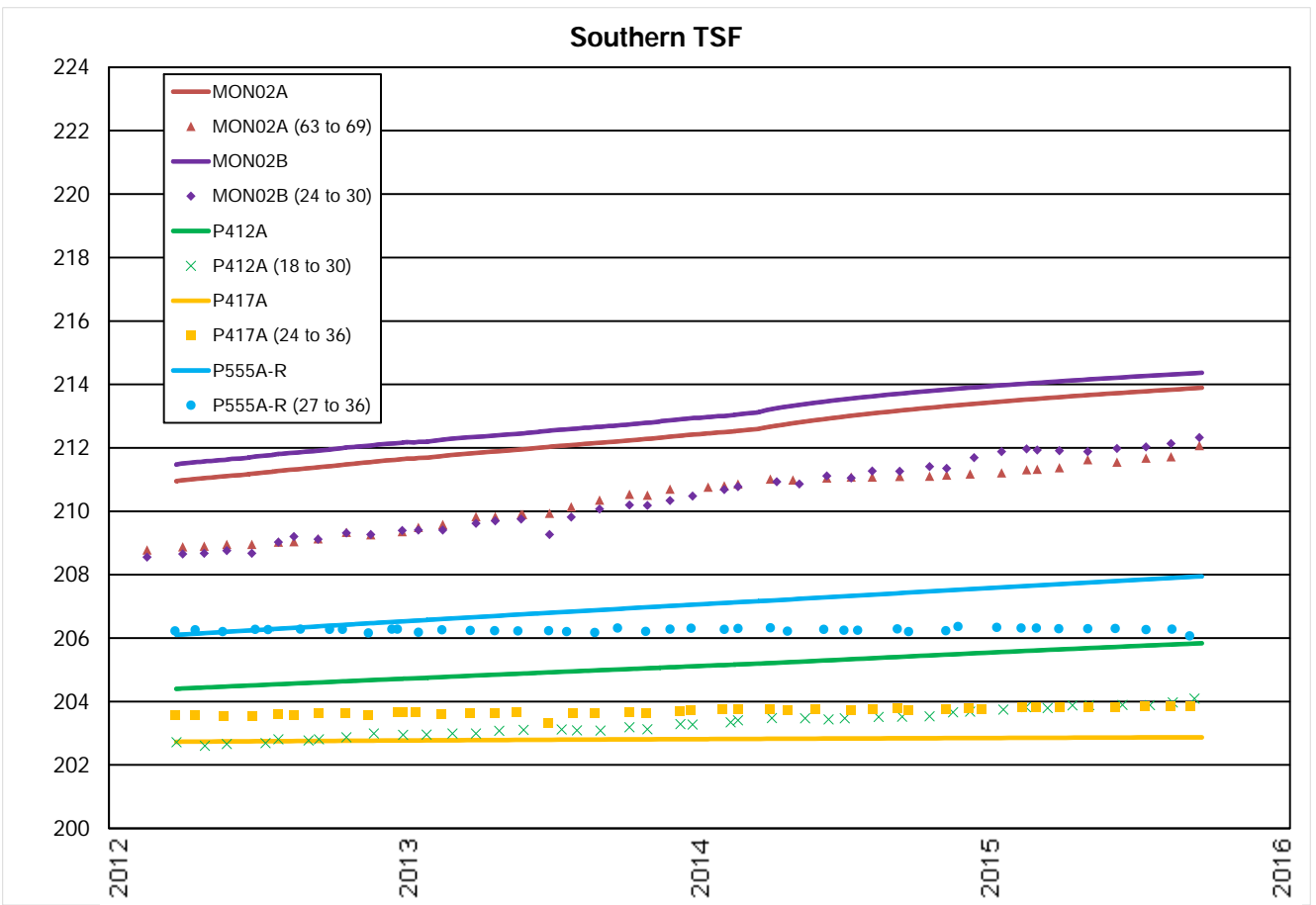
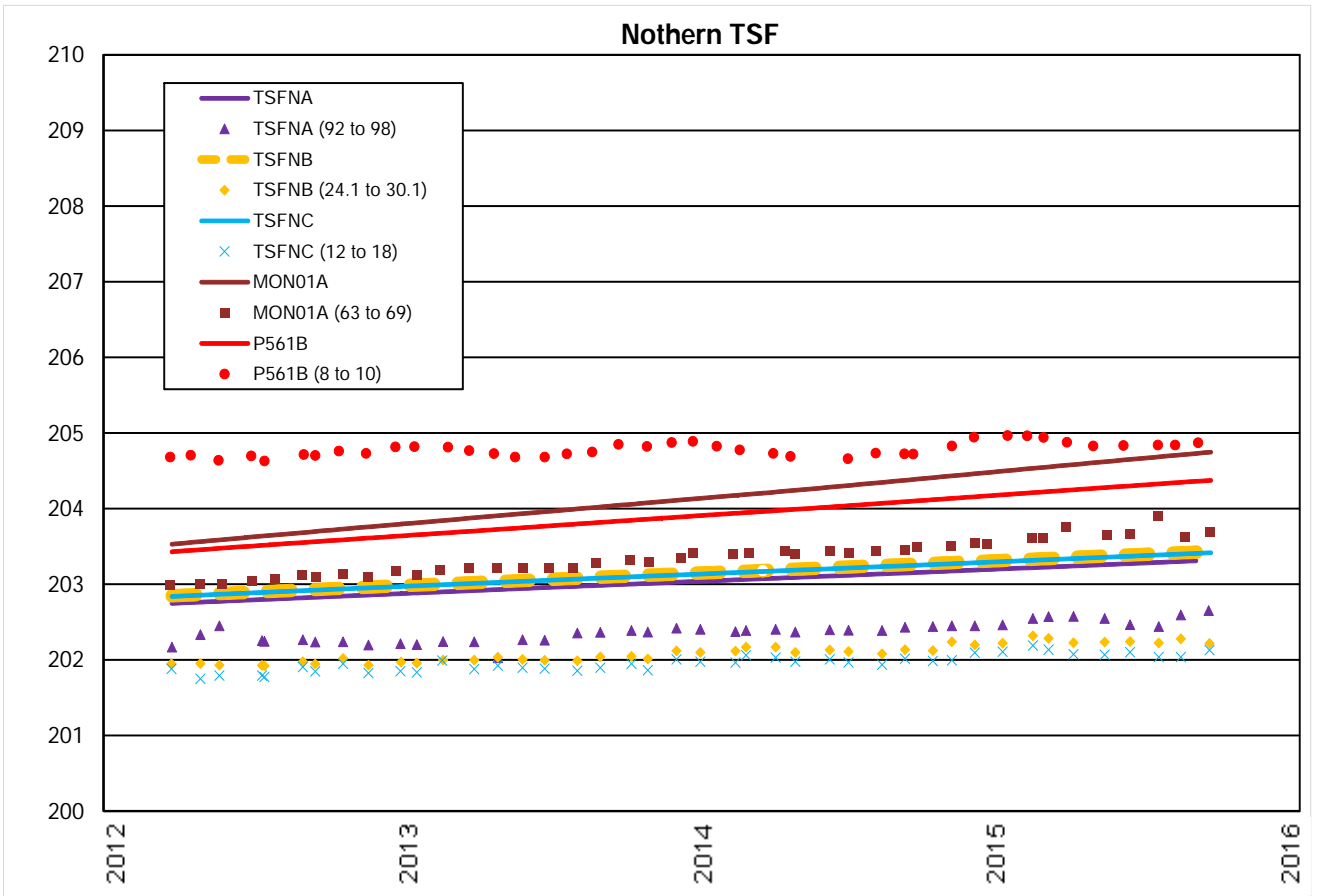

KEY

Solid line - modelled result
 Points - monitoring data
 PDB1A (82-88) - Bore ID
 (screen interval, mbgl)

| | |
|---------------|-------------|
| drawn | SE |
| approved | RJB |
| date | 09 NOV 2016 |
| scale | As Shown |
| original size | A4 |



| | | |
|-------------|---|-------------------------------|
| client: | EVOLUTION MINING (COWAL) PTY LTD | |
| project: | COWAL GOLD OPERATIONS MINE LIFE MODIFICATION HYDROGEOLOGICAL ASSESSMENT | |
| title: | CALIBRATION HYDROGRAPHS - TSF AREA | |
| project no: | GEOTLCOV21910BG | figure no: FIGURE A-18 |

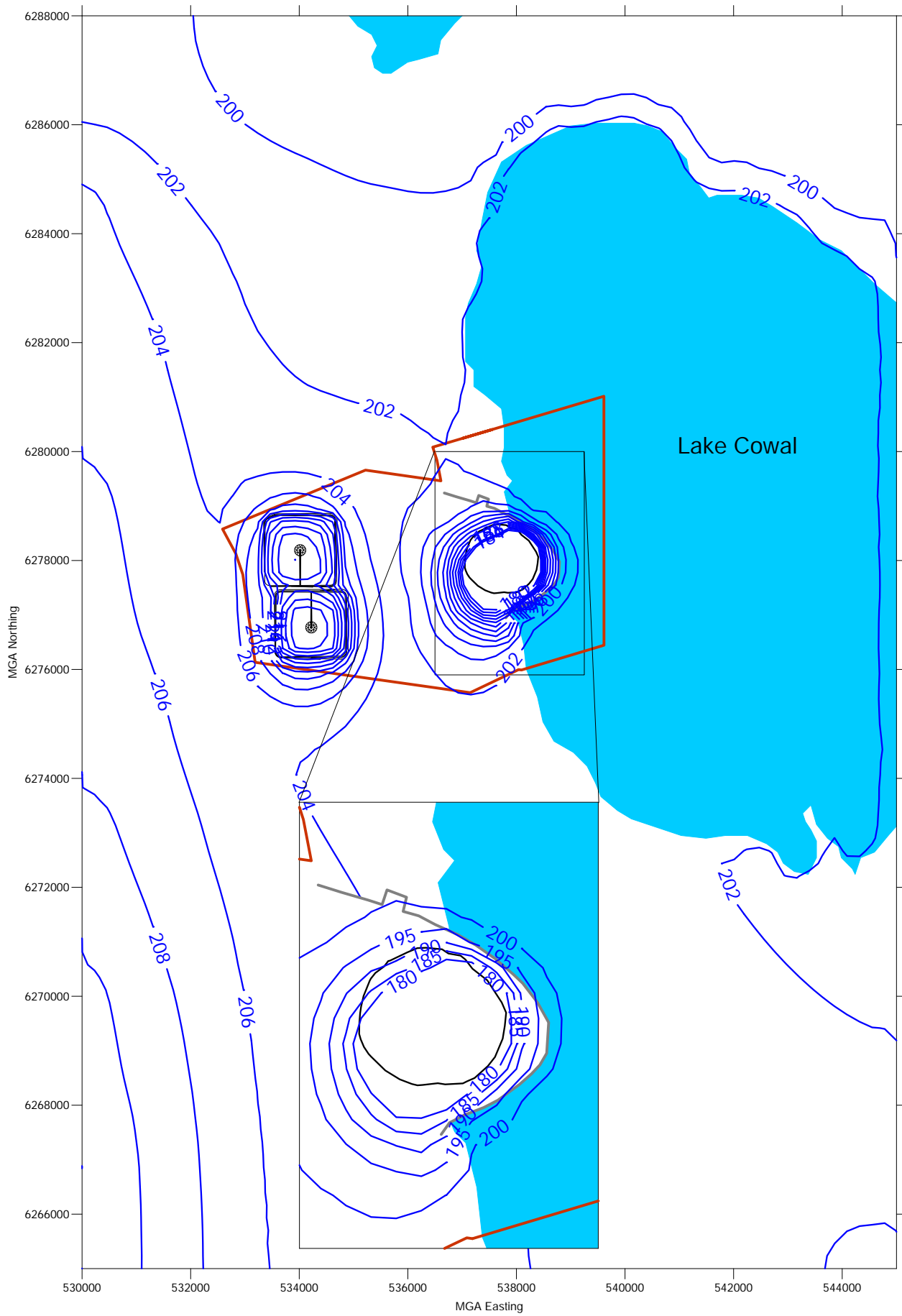

LEGEND

- Approximate Extent of Open Pit
- Lake Protection Bund
- Mine Lease Boundary
- Model Predicted Groundwater Head (m AHD)

| | |
|---------------|-------------------------------|
| drawn | SE |
| approved | RJB |
| date | 09 NOV 2016 |
| scale | 1:100,000 (inset 1:50,000) |
| original size | A4 |



| | | |
|-------------|---|-------------------------------|
| client: | EVOLUTION MINING (COWAL) PTY LTD | |
| project: | COWAL GOLD OPERATIONS MINE LIFE MODIFICATION HYDROGEOLOGICAL ASSESSMENT | |
| title: | MODELLED GROUNDWATER HEAD IN TRANSPORTED UNIT AT JUNE 2016 | |
| project no: | GEOTLCOV21910BG | figure no: FIGURE A-19 |

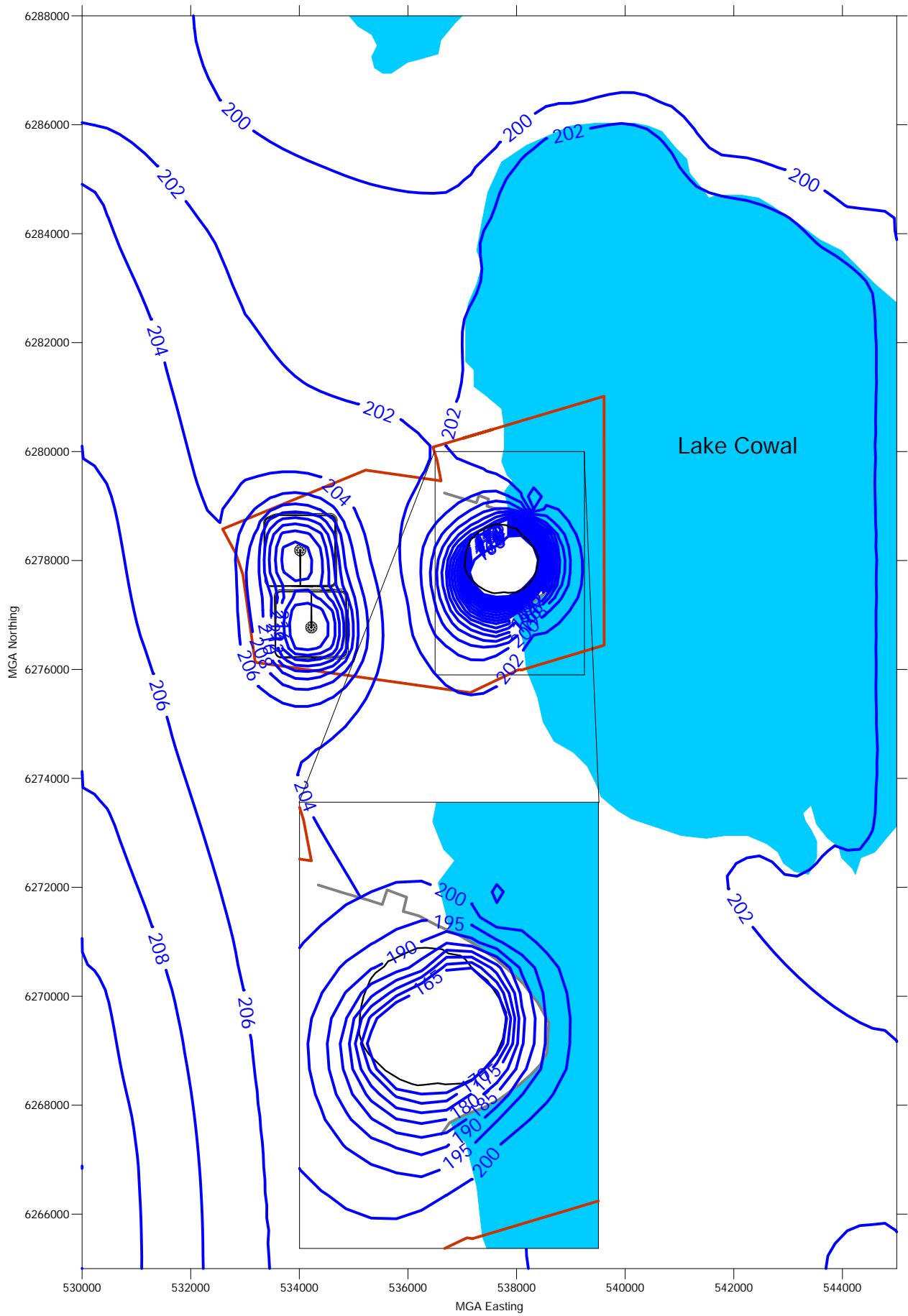

LEGEND

- Approximate Extent of Open Pit
- Lake Protection Bund
- Mine Lease Boundary
- Model Predicted Groundwater Head (m AHD)

| | |
|---------------|-------------------------------|
| drawn | SE |
| approved | RJB |
| date | 09 NOV 2016 |
| scale | 1:100,000 (inset 1:50,000) |
| original size | A4 |



| | | |
|-------------|---|-------------------------------|
| client: | EVOLUTION MINING (COWAL) PTY LTD | |
| project: | COWAL GOLD OPERATIONS MINE LIFE MODIFICATION HYDROGEOLOGICAL ASSESSMENT | |
| title: | MODELLLED GROUNDWATER HEAD IN SAPROLITE UNIT AT JUNE 2016 | |
| project no: | GEOTLCOV21910BG | figure no: FIGURE A-20 |

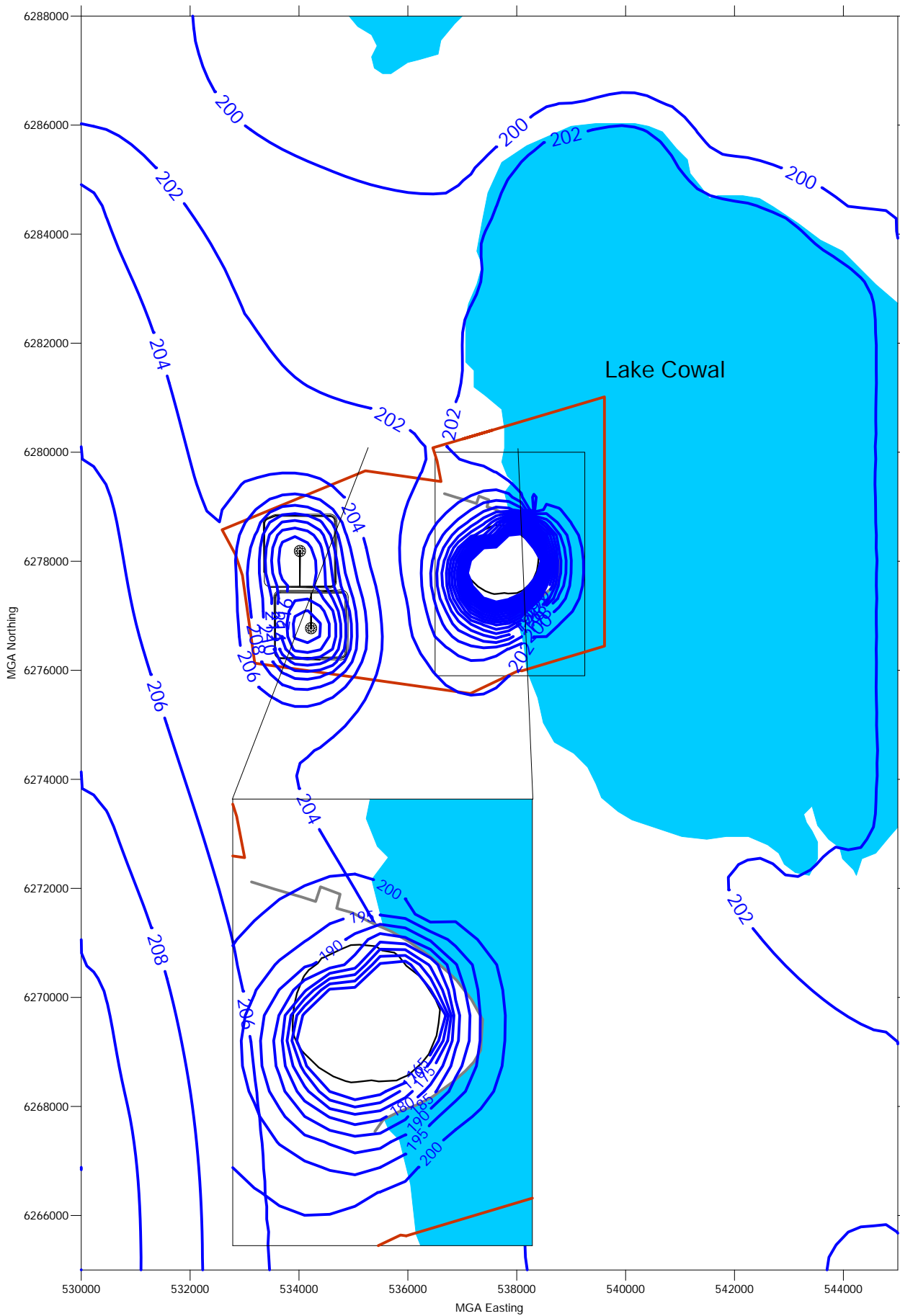

LEGEND

- Approximate Extent of Open Pit
- Lake Protection Bund
- Mine Lease Boundary
- Model Predicted Groundwater Head (m AHD)

| | |
|---------------|-------------------------------|
| drawn | SE |
| approved | RJB |
| date | 09 NOV 2016 |
| scale | 1:100,000 (inset 1:50,000) |
| original size | A4 |



| | | |
|-------------|---|-------------------------------|
| client: | EVOLUTION MINING (COWAL) PTY LTD | |
| project: | COWAL GOLD OPERATIONS MINE LIFE MODIFICATION HYDROGEOLOGICAL ASSESSMENT | |
| title: | MODELLLED GROUNDWATER HEAD IN SAPROCK UNIT AT JUNE 2016 | |
| project no: | GEOTLCOV21910BG | figure no: FIGURE A-21 |

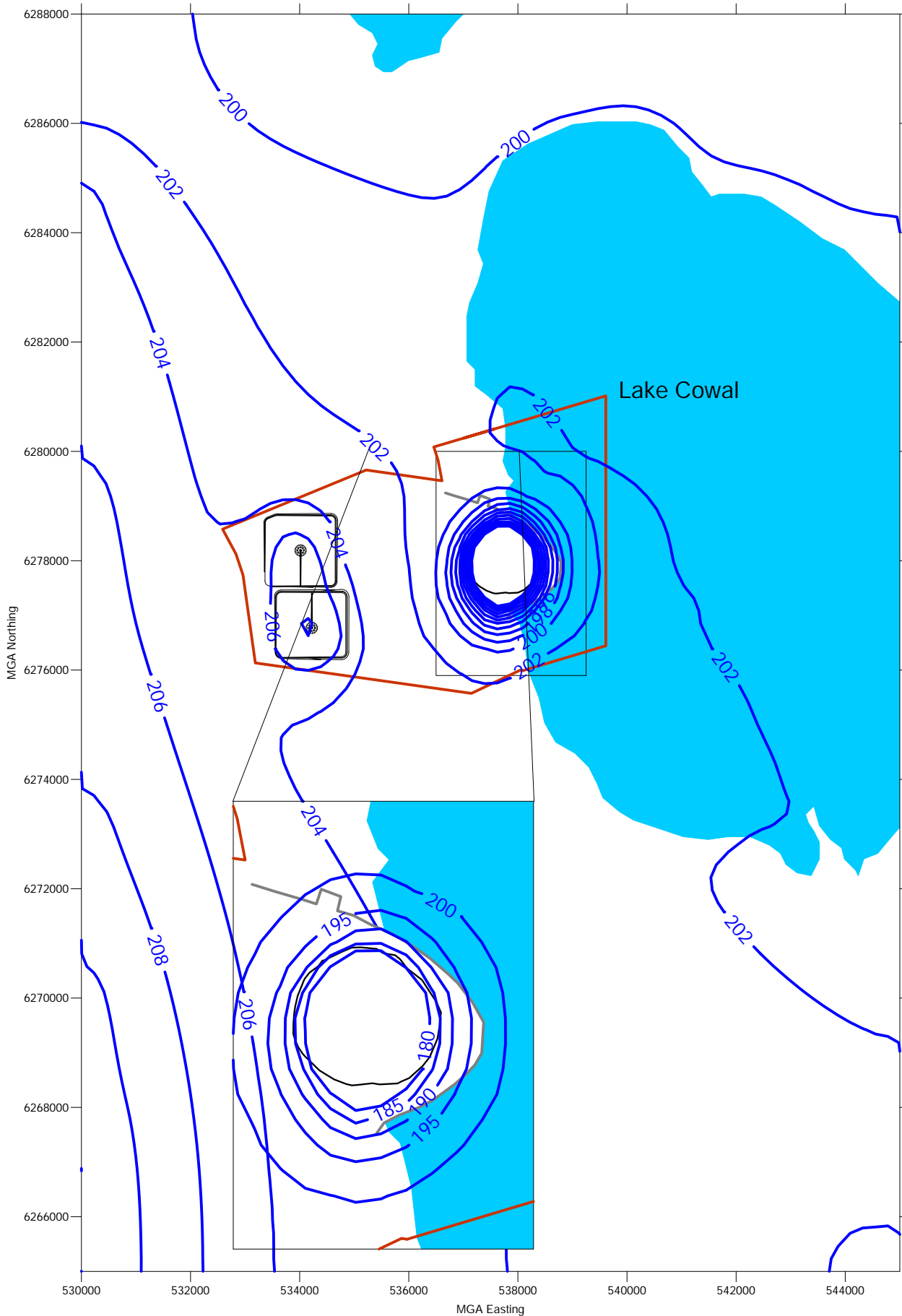

LEGEND

- Approximate Extent of Open Pit
- Lake Protection Bund
- Mine Lease Boundary
- Model Predicted Groundwater Head (m AHD)

| | |
|---------------|-------------------------------|
| drawn | SE |
| approved | RJB |
| date | 09 NOV 2016 |
| scale | 1:100,000 (inset 1:50,000) |
| original size | A4 |



| | | |
|-------------|---|-------------------------------|
| client: | EVOLUTION MINING (COWAL) PTY LTD | |
| project: | COWAL GOLD OPERATIONS MINE LIFE MODIFICATION HYDROGEOLOGICAL ASSESSMENT | |
| title: | MODELLED GROUNDWATER HEAD IN PRIMARY ROCK UNIT AT JUNE 2016 | |
| project no: | GEOTLCOV21910BG | figure no: FIGURE A-22 |

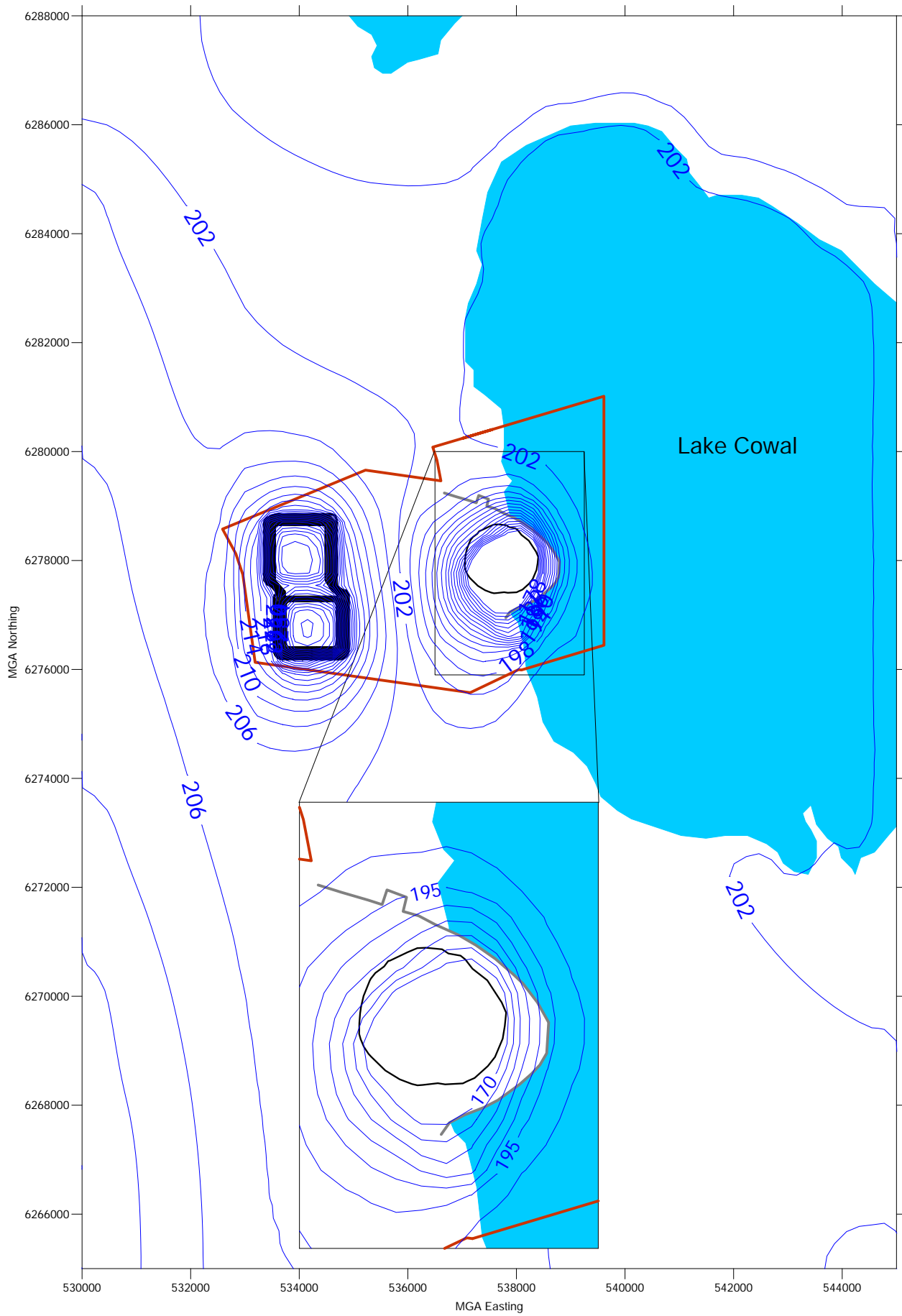

LEGEND

- Approximate Extent of Open Pit
- Lake Protection Bund
- Mine Lease Boundary
- Model Predicted Groundwater Head (m AHD)

| | |
|---------------|-------------------------------|
| drawn | SE |
| approved | RJB |
| date | 02 Nov 2016 |
| scale | 1:100,000 (inset 1:50,000) |
| original size | A4 |



| | | |
|-------------|--|-------------------------------|
| client: | EVOLUTION MINING (COWAL) PTY LTD | |
| project: | COWAL GOLD OPERATIONS MINE LIFE MODIFICATION HYDROGEOLOGICAL ASSESSMENT | |
| title: | MODELLLED GROUNDWATER HEAD IN TRANSPORTED UNIT AT JUNE 2032, DRY LAKE | |
| project no: | GEOTLCOV21910BG | figure no: FIGURE A-23 |

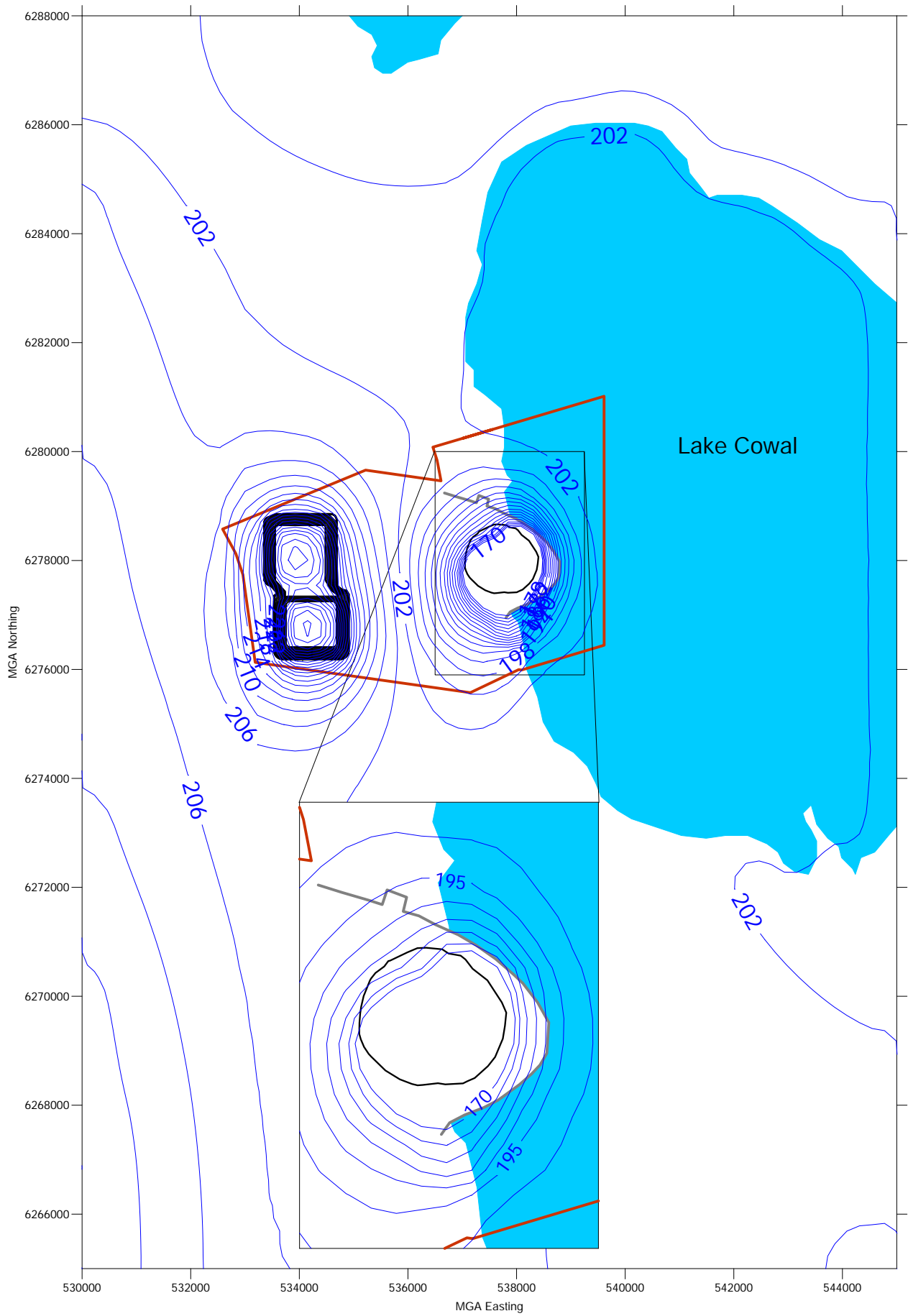

LEGEND

- Approximate Extent of Open Pit
- Lake Protection Bund
- Mine Lease Boundary
- Model Predicted Groundwater Head (m AHD)

| | |
|---------------|-------------------------------|
| drawn | SE |
| approved | RJB |
| date | 02 Nov 2016 |
| scale | 1:100,000 (inset 1:50,000) |
| original size | A4 |



| | | |
|-------------|---|-------------------------------|
| client: | EVOLUTION MINING (COWAL) PTY LTD | |
| project: | COWAL GOLD OPERATIONS MINE LIFE MODIFICATION HYDROGEOLOGICAL ASSESSMENT | |
| title: | MODELLED GROUNDWATER HEAD IN SAPROLITE UNIT AT JUNE 2032, DRY LAKE | |
| project no: | GEOTLCOV21910BG | figure no: FIGURE A-24 |

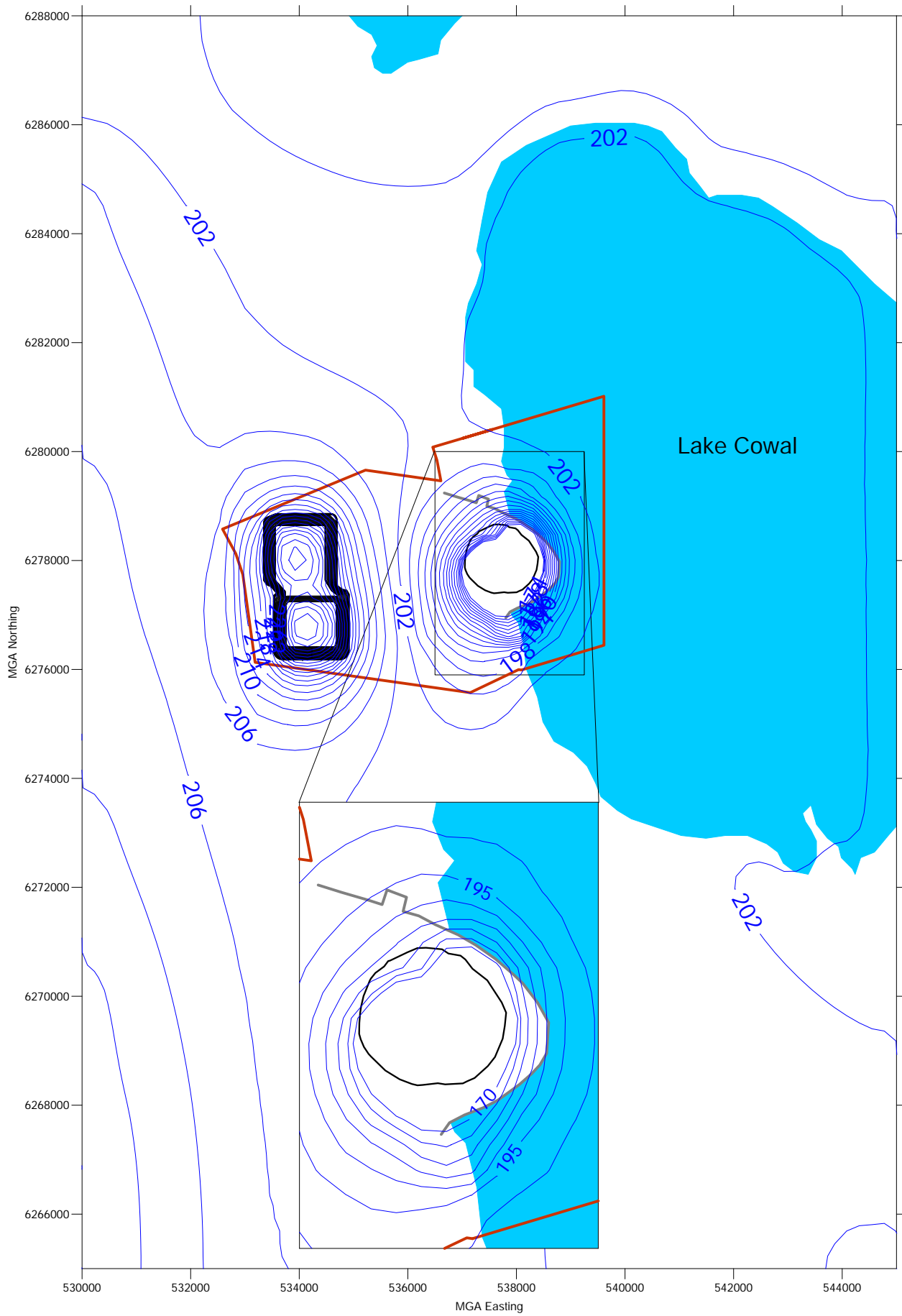

LEGEND

- Approximate Extent of Open Pit
- Lake Protection Bund
- Mine Lease Boundary
- Model Predicted Groundwater Head (m AHD)

| | |
|---------------|-------------------------------|
| drawn | SE |
| approved | RJB |
| date | 02 Nov 2016 |
| scale | 1:100,000 (inset 1:50,000) |
| original size | A4 |



| | | |
|-------------|---|-------------------------------|
| client: | EVOLUTION MINING (COWAL) PTY LTD | |
| project: | COWAL GOLD OPERATIONS MINE LIFE MODIFICATION HYDROGEOLOGICAL ASSESSMENT | |
| title: | MODELLED GROUNDWATER HEAD IN SAPROCK UNIT AT JUNE 2032, DRY LAKE | |
| project no: | GEOTLCOV21910BG | figure no: FIGURE A-25 |

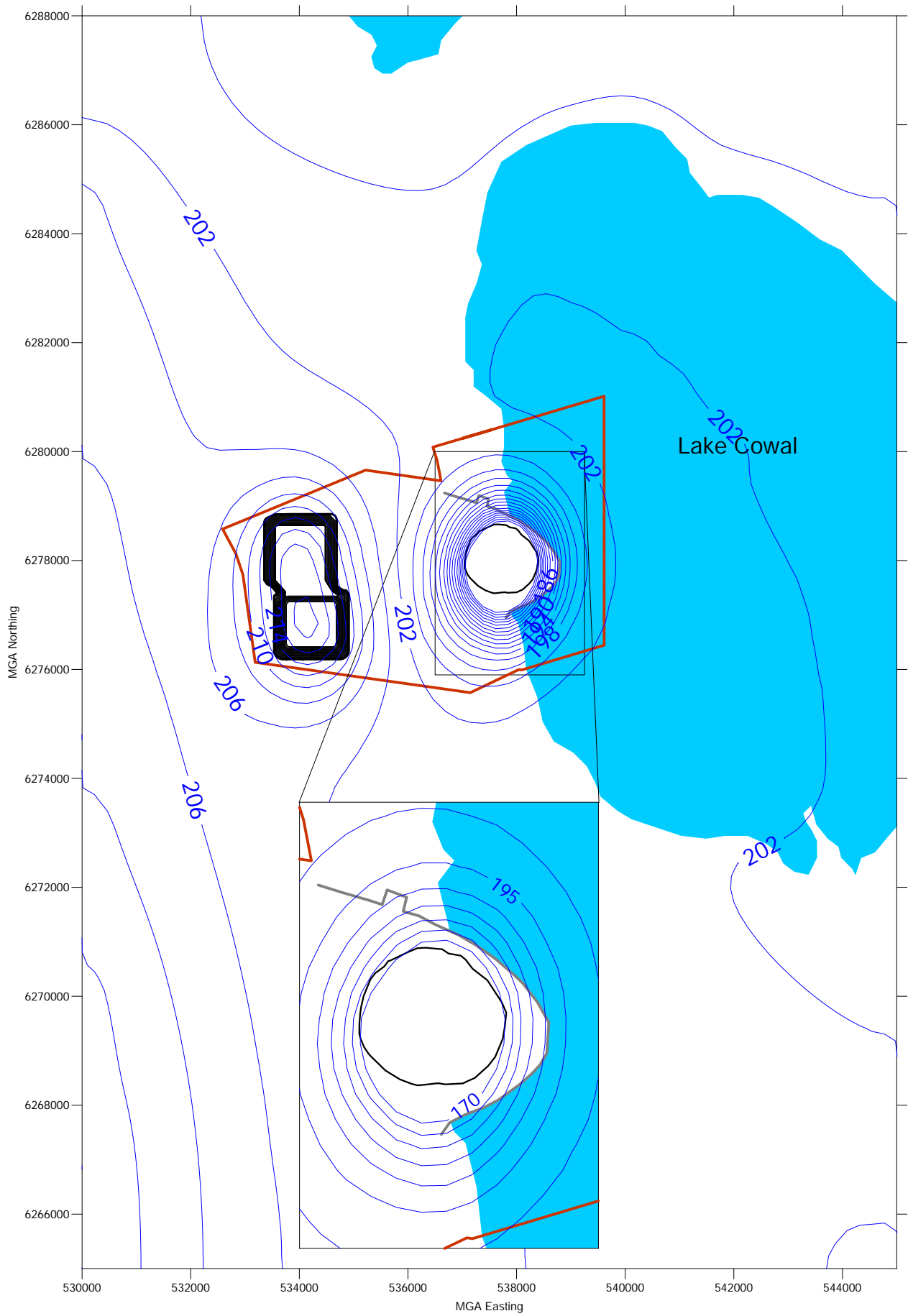

LEGEND

- Approximate Extent of Open Pit
- Lake Protection Bund
- Mine Lease Boundary
- Model Predicted Groundwater Head (m AHD)

| | |
|---------------|-------------------------------|
| drawn | SE |
| approved | RJB |
| date | 02 Nov 2016 |
| scale | 1:100,000 (inset 1:50,000) |
| original size | A4 |



| | | |
|-------------|---|-------------------------------|
| client: | EVOLUTION MINING (COWAL) PTY LTD | |
| project: | COWAL GOLD OPERATIONS MINE LIFE MODIFICATION HYDROGEOLOGICAL ASSESSMENT | |
| title: | MODELLERD GROUNDWATER HEAD IN PRIMARY ROCK UNIT AT JUNE 2032, DRY LAKE | |
| project no: | GEOTLCOV21910BG | figure no: FIGURE A-26 |

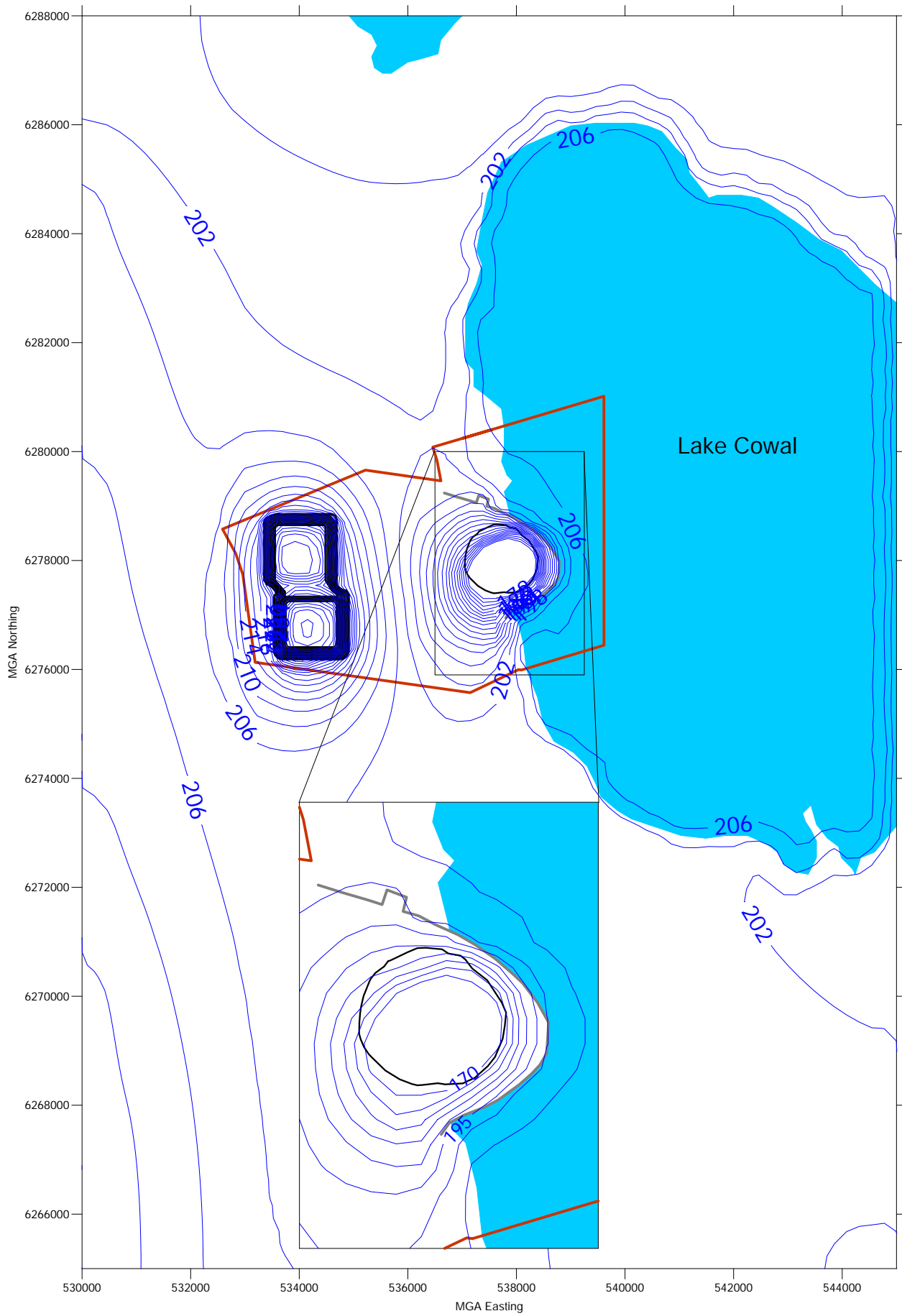

LEGEND

- Approximate Extent of Open Pit
- Lake Protection Bund
- Mine Lease Boundary
- Model Predicted Groundwater Head (m AHD)

| | |
|---------------|-------------------------------|
| drawn | SE |
| approved | RJB |
| date | 02 Nov 2016 |
| scale | 1:100,000 (inset 1:50,000) |
| original size | A4 |



| | | |
|-------------|---|-------------------------------|
| client: | EVOLUTION MINING (COWAL) PTY LTD | |
| project: | COWAL GOLD OPERATIONS MINE LIFE MODIFICATION HYDROGEOLOGICAL ASSESSMENT | |
| title: | MODELLED GROUNDWATER HEAD IN TRANSPORTED UNIT AT JUNE 2032, INUNDATED LAKE | |
| project no: | GEOTLCOV21910BG | figure no: FIGURE A-27 |

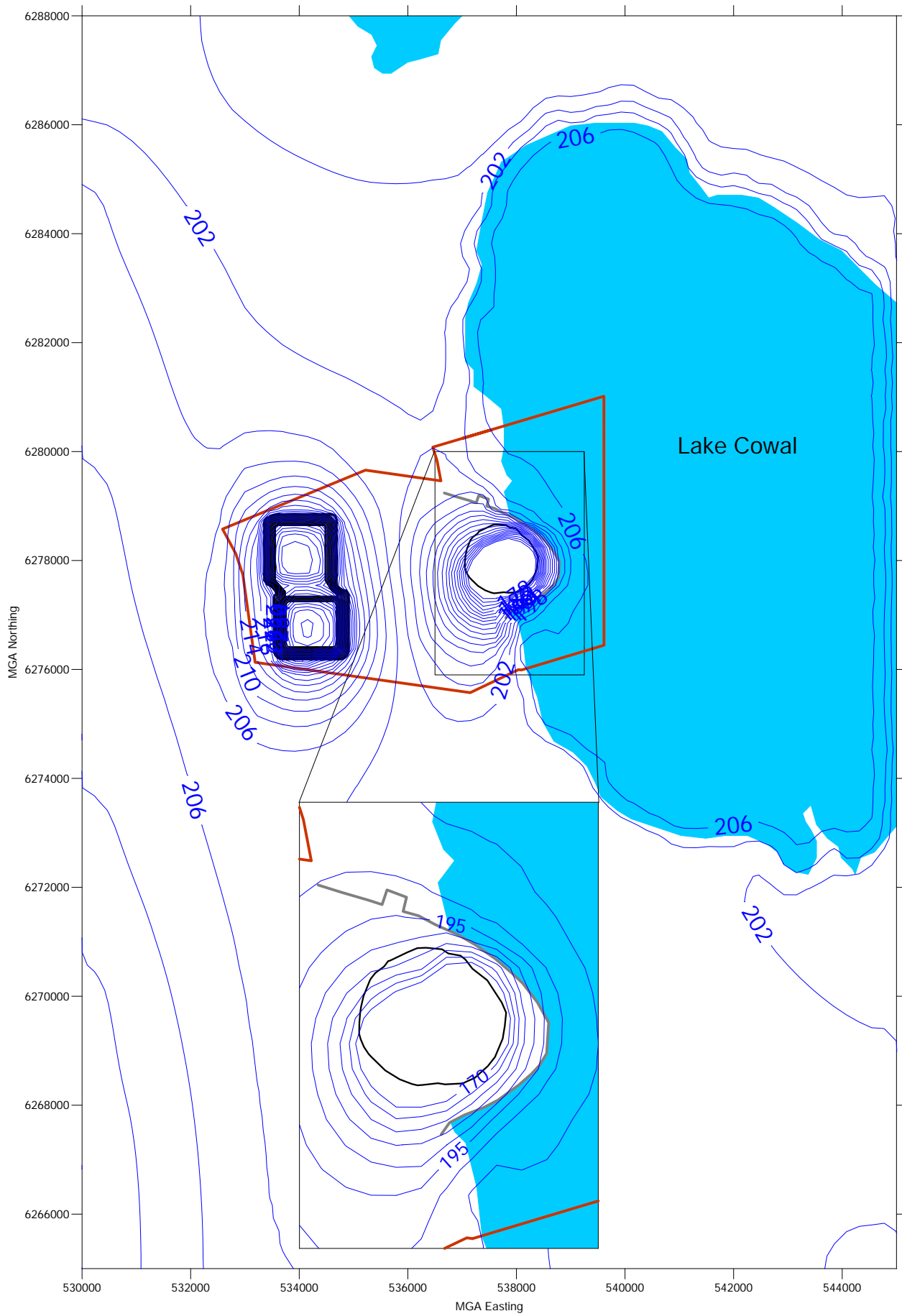

LEGEND

- Approximate Extent of Open Pit
- Lake Protection Bund
- Mine Lease Boundary
- Model Predicted Groundwater Head (m AHD)

| | |
|---------------|-------------------------------|
| drawn | SE |
| approved | RJB |
| date | 02 Nov 2016 |
| scale | 1:100,000 (inset 1:50,000) |
| original size | A4 |



| | | |
|-------------|--|-------------------------------|
| client: | EVOLUTION MINING (COWAL) PTY LTD | |
| project: | COWAL GOLD OPERATIONS MINE LIFE MODIFICATION HYDROGEOLOGICAL ASSESSMENT | |
| title: | MODELLLED GROUNDWATER HEAD IN SAPROLITE UNIT AT JUNE 2032, INUNDATED LAKE | |
| project no: | GEOTLCOV21910BG | figure no: FIGURE A-28 |

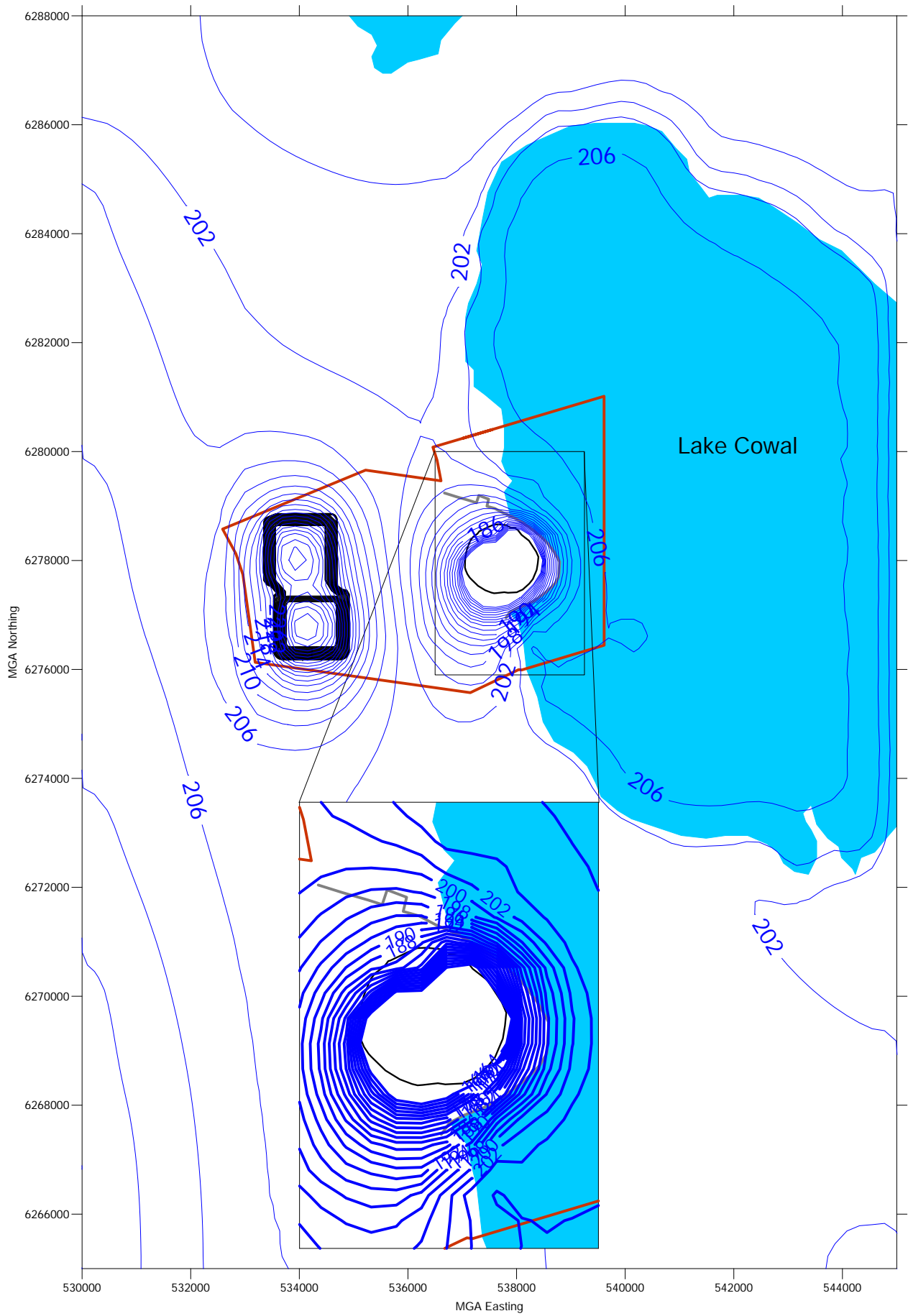

LEGEND

- Approximate Extent of Open Pit
- Lake Protection Bund
- Mine Lease Boundary
- Model Predicted Groundwater Head (m AHD)

| | |
|---------------|-------------------------------|
| drawn | SE |
| approved | RJB |
| date | 02 Nov 2016 |
| scale | 1:100,000 (inset 1:50,000) |
| original size | A4 |



| | | |
|-------------|---|-------------------------------|
| client: | EVOLUTION MINING (COWAL) PTY LTD | |
| project: | COWAL GOLD OPERATIONS MINE LIFE MODIFICATION HYDROGEOLOGICAL ASSESSMENT | |
| title: | MODELLED GROUNDWATER HEAD IN SAPROCK UNIT AT JUNE 2032, INUNDATED LAKE | |
| project no: | GEOTLCOV21910BG | figure no: FIGURE A-29 |

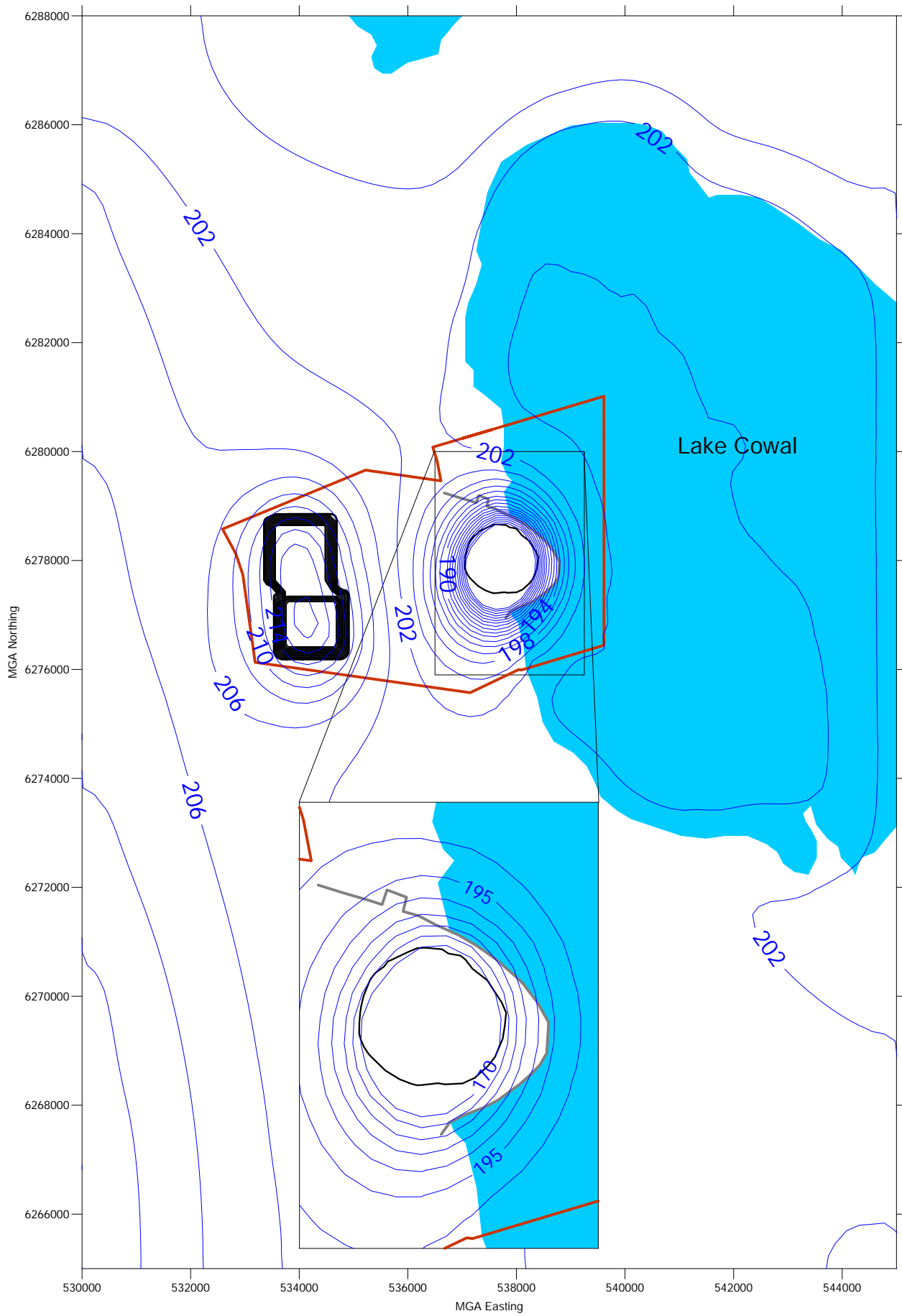

LEGEND

- Approximate Extent of Open Pit
- Lake Protection Bund
- Mine Lease Boundary
- Model Predicted Groundwater Head (m AHD)

| | |
|---------------|-------------------------------|
| drawn | SE |
| approved | RJB |
| date | 02 Nov 2016 |
| scale | 1:100,000 (inset 1:50,000) |
| original size | A4 |



| | | |
|-------------|--|-------------------------------|
| client: | EVOLUTION MINING (COWAL) PTY LTD | |
| project: | COWAL GOLD OPERATIONS MINE LIFE MODIFICATION HYDROGEOLOGICAL ASSESSMENT | |
| title: | MODELLED GROUNDWATER HEAD IN PRIMARY ROCK UNIT AT JUNE 2032, INUNDATED LAKE | |
| project no: | GEOTLCOV21910BG | figure no: FIGURE A-30 |

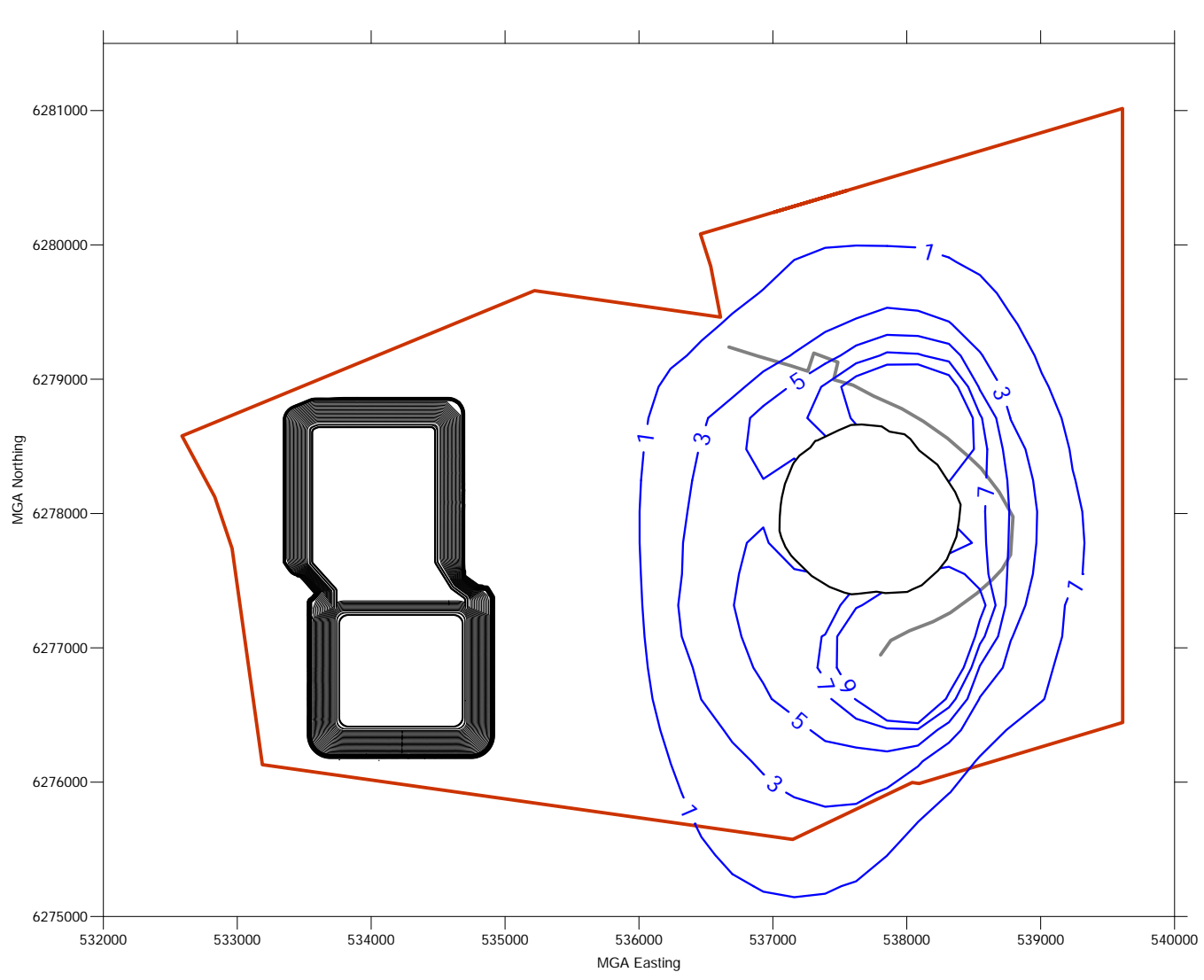

LEGEND

- Approximate Extent of Open Pit
- Lake Protection Bund
- Mine Lease Boundary
- Model Predicted Groundwater Drawdown (m)

| | |
|---------------|-------------|
| drawn | SE |
| approved | RJB |
| date | 02 Nov 2016 |
| scale | 1:50,000 |
| original size | A4 |



| | | |
|-------------|--|-------------------------------|
| client: | EVOLUTION MINING (COWAL) PTY LTD | |
| project: | COWAL GOLD OPERATIONS MINE LIFE MODIFICATION HYDROGEOLOGICAL ASSESSMENT | |
| title: | MODELLERD GROUNDWATER DRAWDOWN IN TRANS-PORTED UNIT AT END OF MINE LIFE, DRY LAKE | |
| project no: | GEOTLCOV21910BG | figure no: FIGURE A-31 |

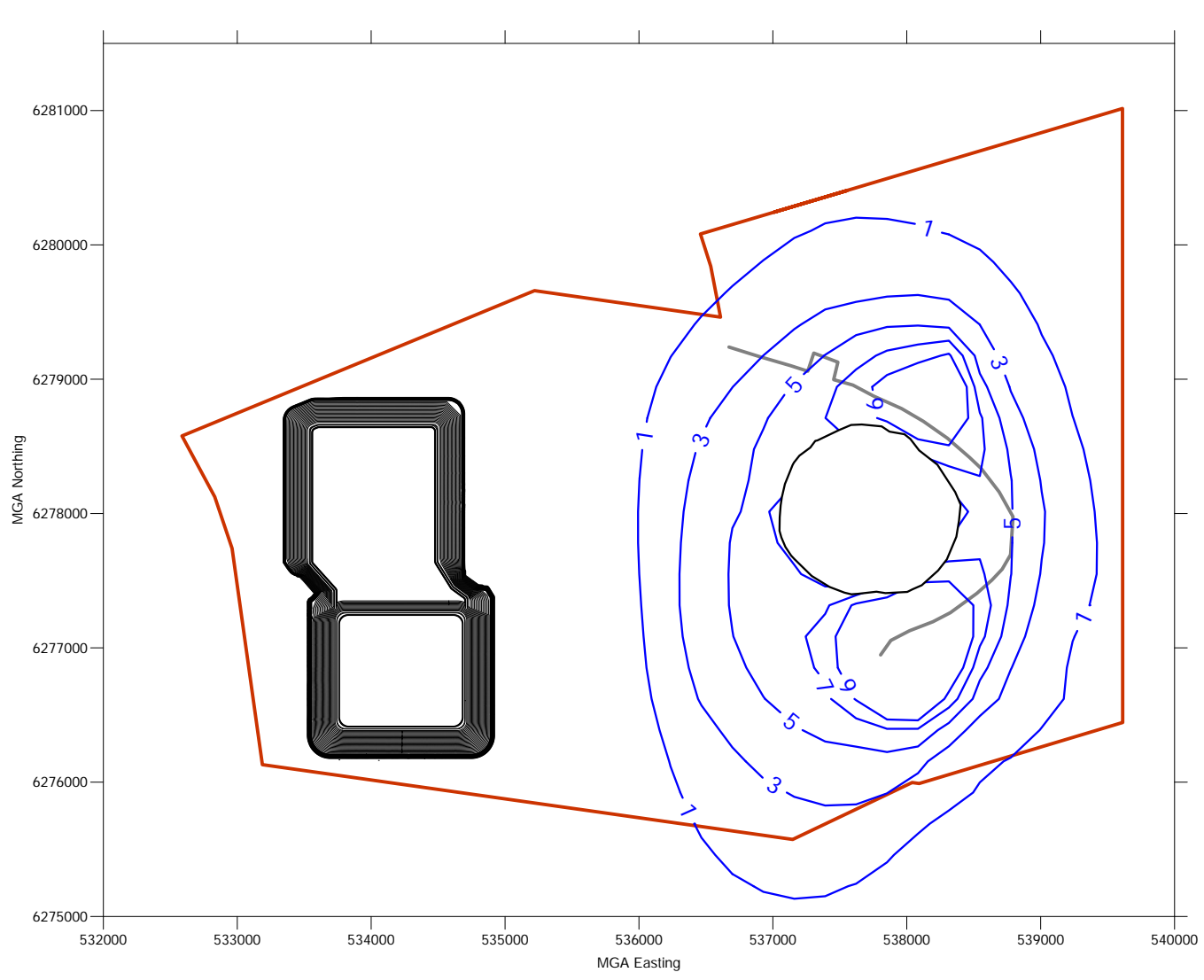

LEGEND

- Approximate Extent of Open Pit
- Lake Protection Bund
- Mine Lease Boundary
- Model Predicted Groundwater Drawdown (m)

| | |
|---------------|-------------|
| drawn | SE |
| approved | RJB |
| date | 02 Nov 2016 |
| scale | 1:50,000 |
| original size | A4 |



| | | |
|-------------|---|-------------------------------|
| client: | EVOLUTION MINING (COWAL) PTY LTD | |
| project: | COWAL GOLD OPERATIONS MINE LIFE MODIFICATION HYDROGEOLOGICAL ASSESSMENT | |
| title: | MODELLERD GROUNDWATER DRAWDOWN IN SAPROLITE UNIT AT END OF MINE LIFE, DRY LAKE | |
| project no: | GEOTLCOV21910BG | figure no: FIGURE A-32 |

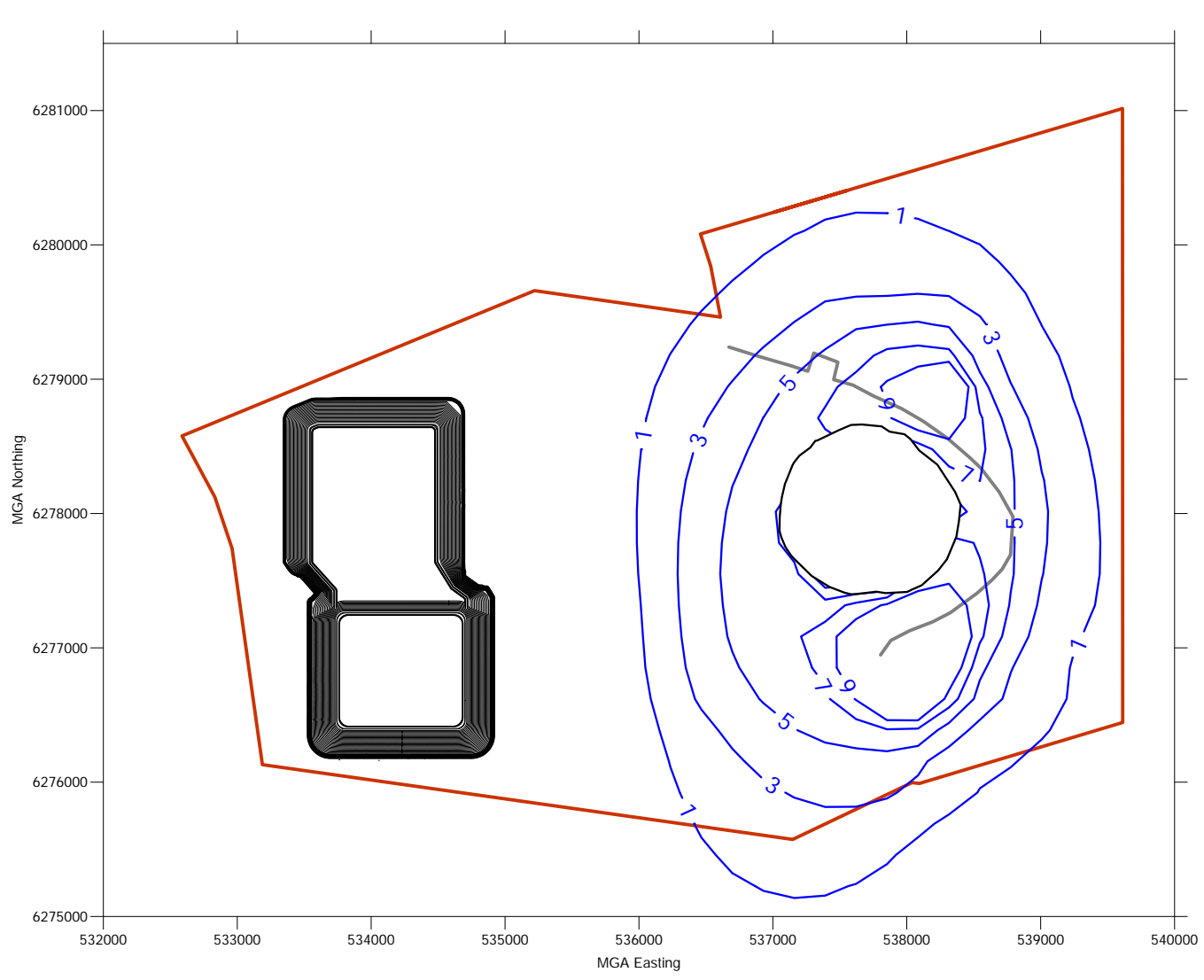

LEGEND

- Approximate Extent of Open Pit
- Lake Protection Bund
- Mine Lease Boundary
- Model Predicted Groundwater Drawdown (m)

| | |
|---------------|-------------|
| drawn | SE |
| approved | RJB |
| date | 02 Nov 2016 |
| scale | 1:50,000 |
| original size | A4 |



| | | |
|-------------|--|-------------------------------|
| client: | EVOLUTION MINING (COWAL) PTY LTD | |
| project: | COWAL GOLD OPERATIONS MINE LIFE MODIFICATION HYDROGEOLOGICAL ASSESSMENT | |
| title: | MODELLED GROUNDWATER DRAWDOWN IN SAPROCK UNIT AT END OF MINE LIFE, DRY LAKE | |
| project no: | GEOTLCOV21910BG | figure no: FIGURE A-33 |

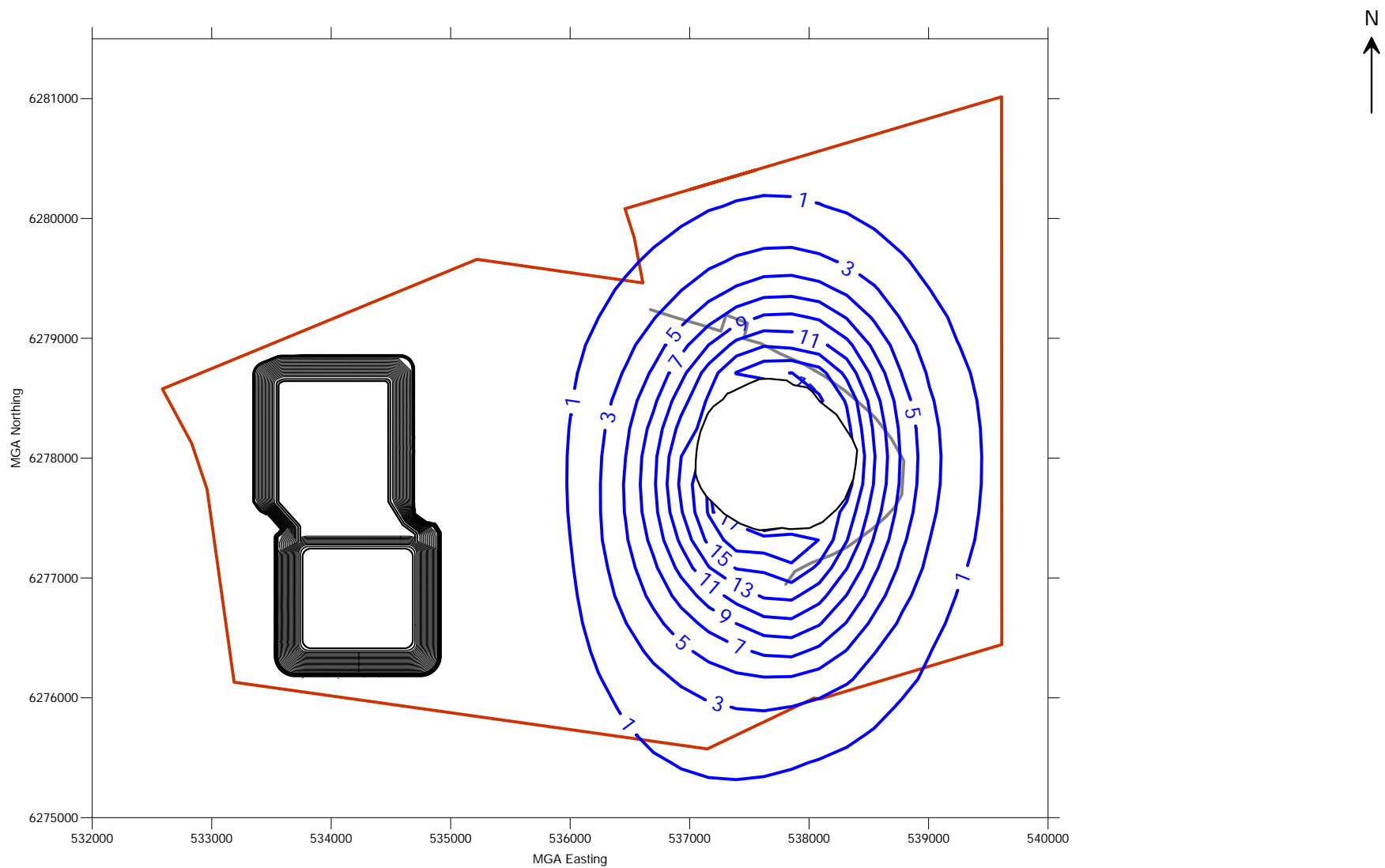

LEGEND

- Approximate Extent of Open Pit
- Lake Protection Bund
- Mine Lease Boundary
- Model Predicted Groundwater Drawdown (m)

| | |
|---------------|-------------|
| drawn | SE |
| approved | RJB |
| date | 02 Nov 2016 |
| scale | 1:50,000 |
| original size | A4 |



| | | |
|-------------|--|-------------------------------|
| client: | EVOLUTION MINING (COWAL) PTY LTD | |
| project: | COWAL GOLD OPERATIONS MINE LIFE MODIFICATION HYDROGEOLOGICAL ASSESSMENT | |
| title: | MODELLERD GROUNDWATER DRAWDOWN IN PRIMARY ROCK UNIT AT END OF MINE LIFE, DRY LAKE | |
| project no: | GEOTLCOV21910BG | figure no: FIGURE A-34 |

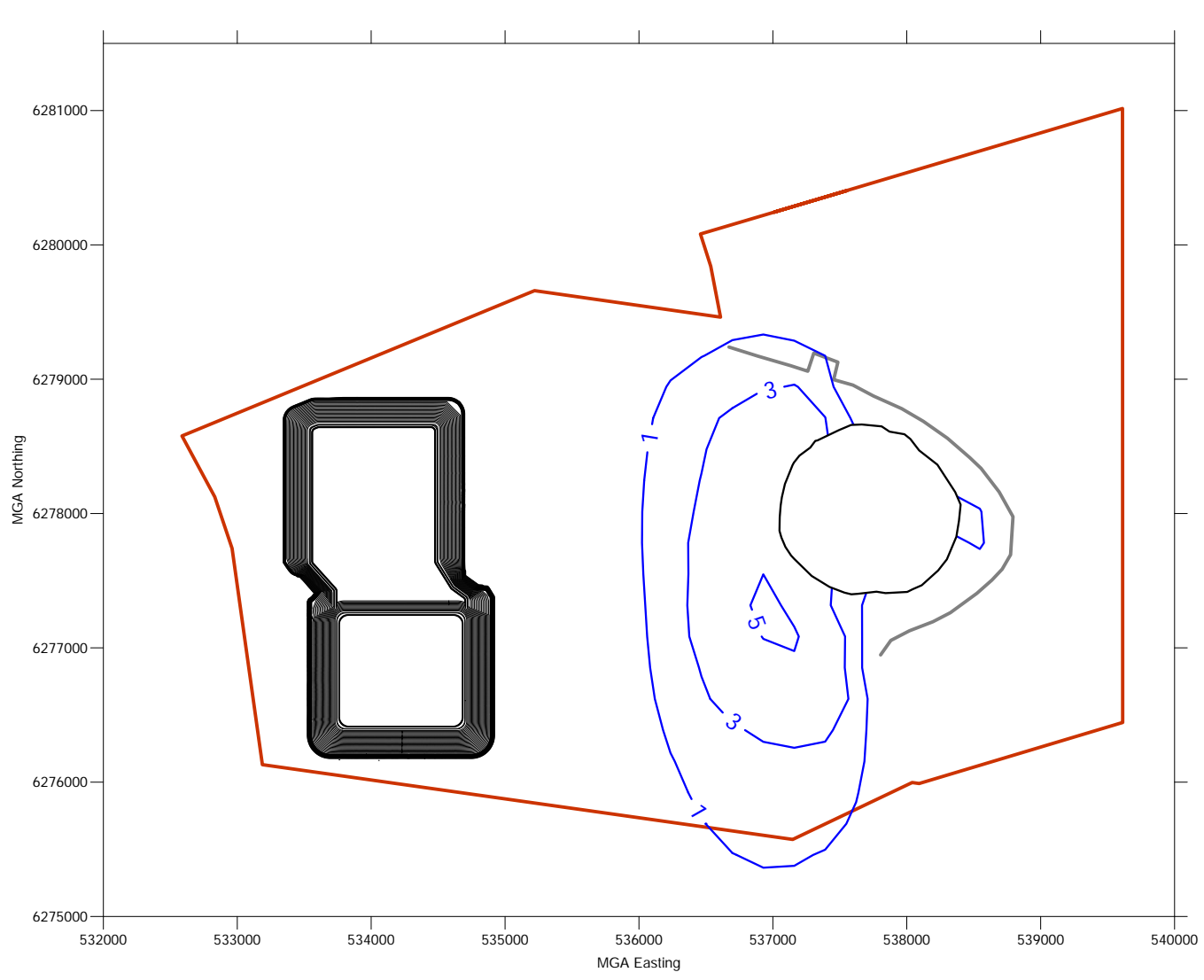

LEGEND

- Approximate Extent of Open Pit
- Lake Protection Bund
- Mine Lease Boundary
- Model Predicted Groundwater Drawdown (m)

| | |
|---------------|-------------|
| drawn | SE |
| approved | RJB |
| date | 02 Nov 2016 |
| scale | 1:50,000 |
| original size | A4 |



| | | |
|-------------|--|-------------------------------|
| client: | EVOLUTION MINING (COWAL) PTY LTD | |
| project: | COWAL GOLD OPERATIONS MINE LIFE MODIFICATION HYDROGEOLOGICAL ASSESSMENT | |
| title: | MODELLED GROUNDWATER DRAWDOWN IN TRANSPORTED UNIT AT END OF MINE LIFE, INUNDATED LAKE | |
| project no: | GEOTLCOV21910BG | figure no: FIGURE A-35 |

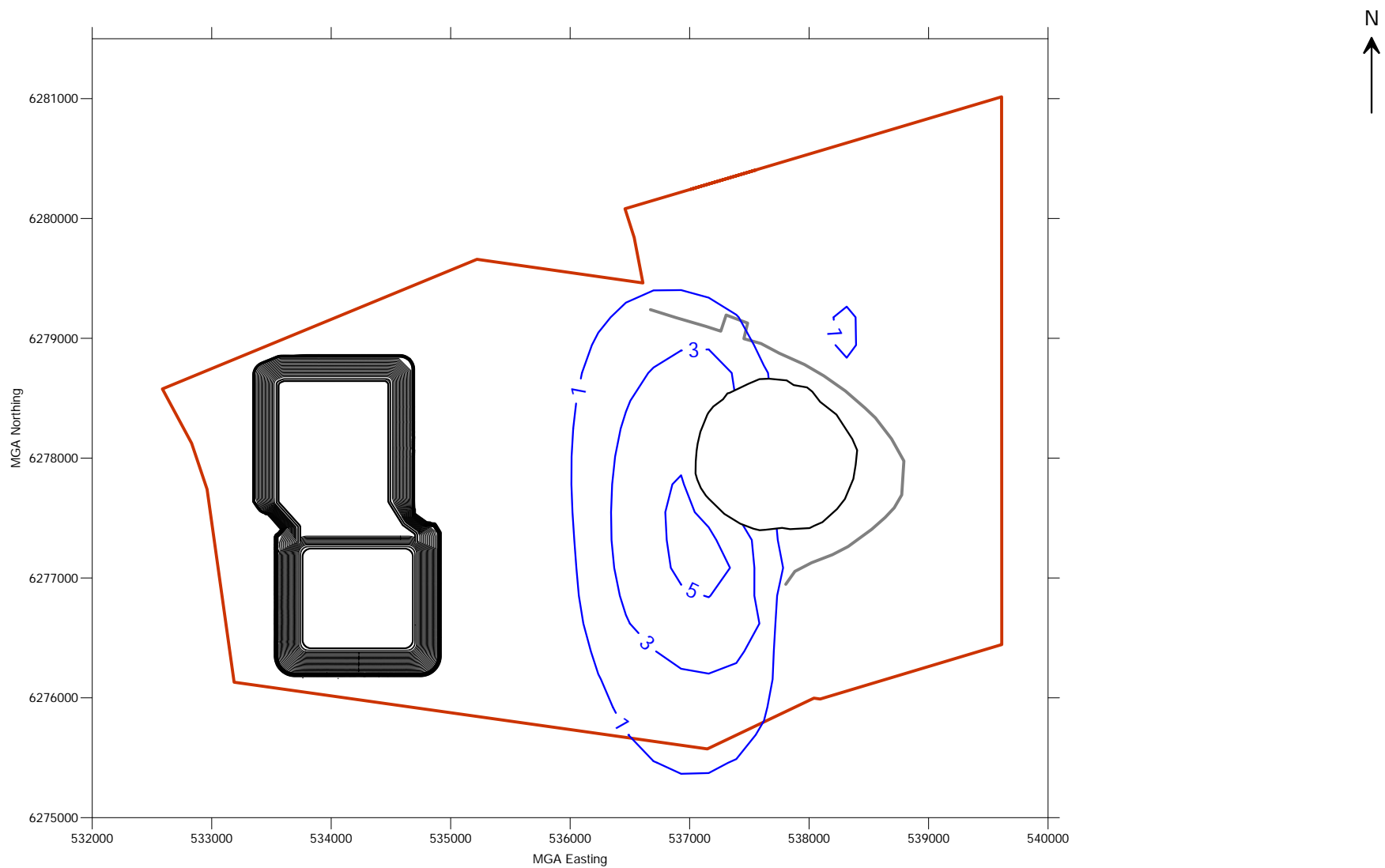

LEGEND

- Approximate Extent of Open Pit
- Lake Protection Bund
- Mine Lease Boundary
- Model Predicted Groundwater Drawdown (m)

| | |
|---------------|-------------|
| drawn | SE |
| approved | RJB |
| date | 02 Nov 2016 |
| scale | 1:50,000 |
| original size | A4 |



| | | |
|-------------|---|-------------------------------|
| client: | EVOLUTION MINING (COWAL) PTY LTD | |
| project: | COWAL GOLD OPERATIONS MINE LIFE MODIFICATION HYDROGEOLOGICAL ASSESSMENT | |
| title: | MODELLED GROUNDWATER DRAWDOWN IN SAPRO-LITE UNIT AT END OF MINE LIFE, INUNDATED LAKE | |
| project no: | GEOTLCOV21910BG | figure no: FIGURE A-36 |

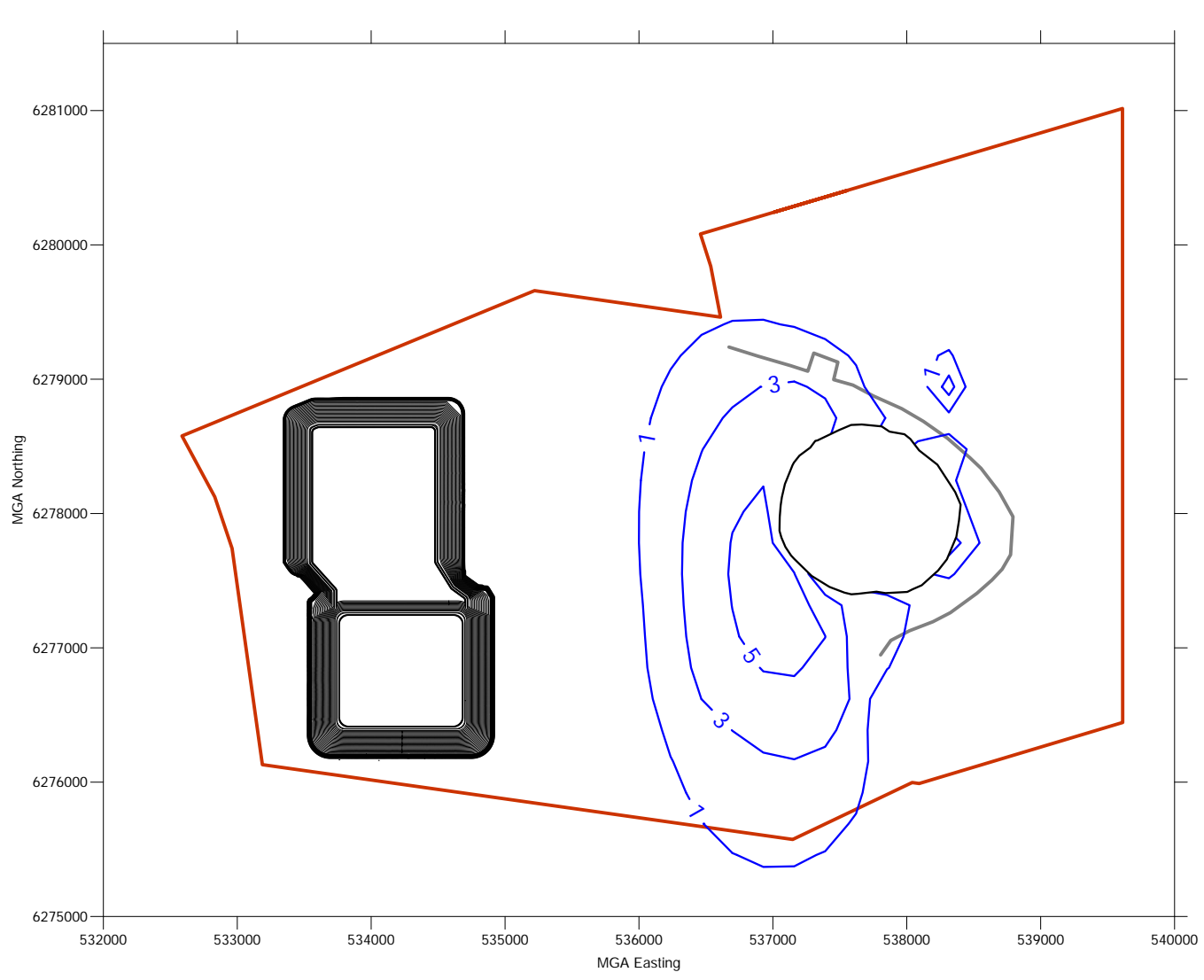

LEGEND

- Approximate Extent of Open Pit
- Lake Protection Bund
- Mine Lease Boundary
- Model Predicted Groundwater Drawdown (m)

| | |
|---------------|-------------|
| drawn | SE |
| approved | RJB |
| date | 02 Nov 2016 |
| scale | 1:50,000 |
| original size | A4 |



| | | |
|-------------|--|-------------------------------|
| client: | EVOLUTION MINING (COWAL) PTY LTD | |
| project: | COWAL GOLD OPERATIONS MINE LIFE MODIFICATION HYDROGEOLOGICAL ASSESSMENT | |
| title: | MODELLED GROUNDWATER DRAWDOWN IN SAPROCK UNIT AT END OF MINE LIFE, INUNDATED LAKE | |
| project no: | GEOTLCOV21910BG | figure no: FIGURE A-37 |

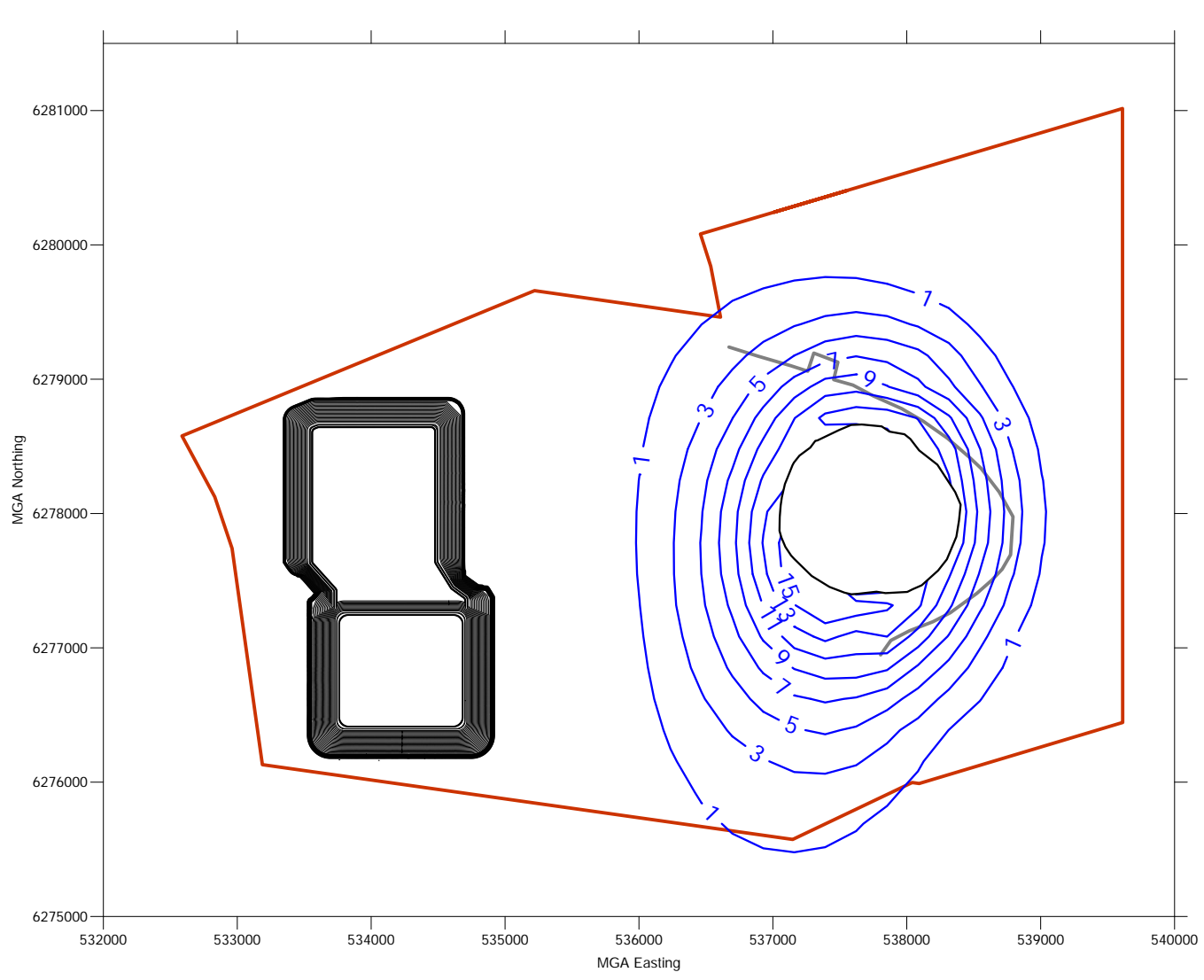

LEGEND

- Approximate Extent of Open Pit
- Lake Protection Bund
- Mine Lease Boundary
- Model Predicted Groundwater Drawdown (m)

| | |
|---------------|-------------|
| drawn | SE |
| approved | RJB |
| date | 02 Nov 2016 |
| scale | 1:50,000 |
| original size | A4 |



| | | |
|-------------|---|-------------------------------|
| client: | EVOLUTION MINING (COWAL) PTY LTD | |
| project: | COWAL GOLD OPERATIONS MINE LIFE MODIFICATION HYDROGEOLOGICAL ASSESSMENT | |
| title: | MODELLED GROUNDWATER DRAWDOWN IN PRIMARY ROCK UNIT AT END OF MINE LIFE, INUNDATED LAKE | |
| project no: | GEOTLCOV21910BG | figure no: FIGURE A-38 |

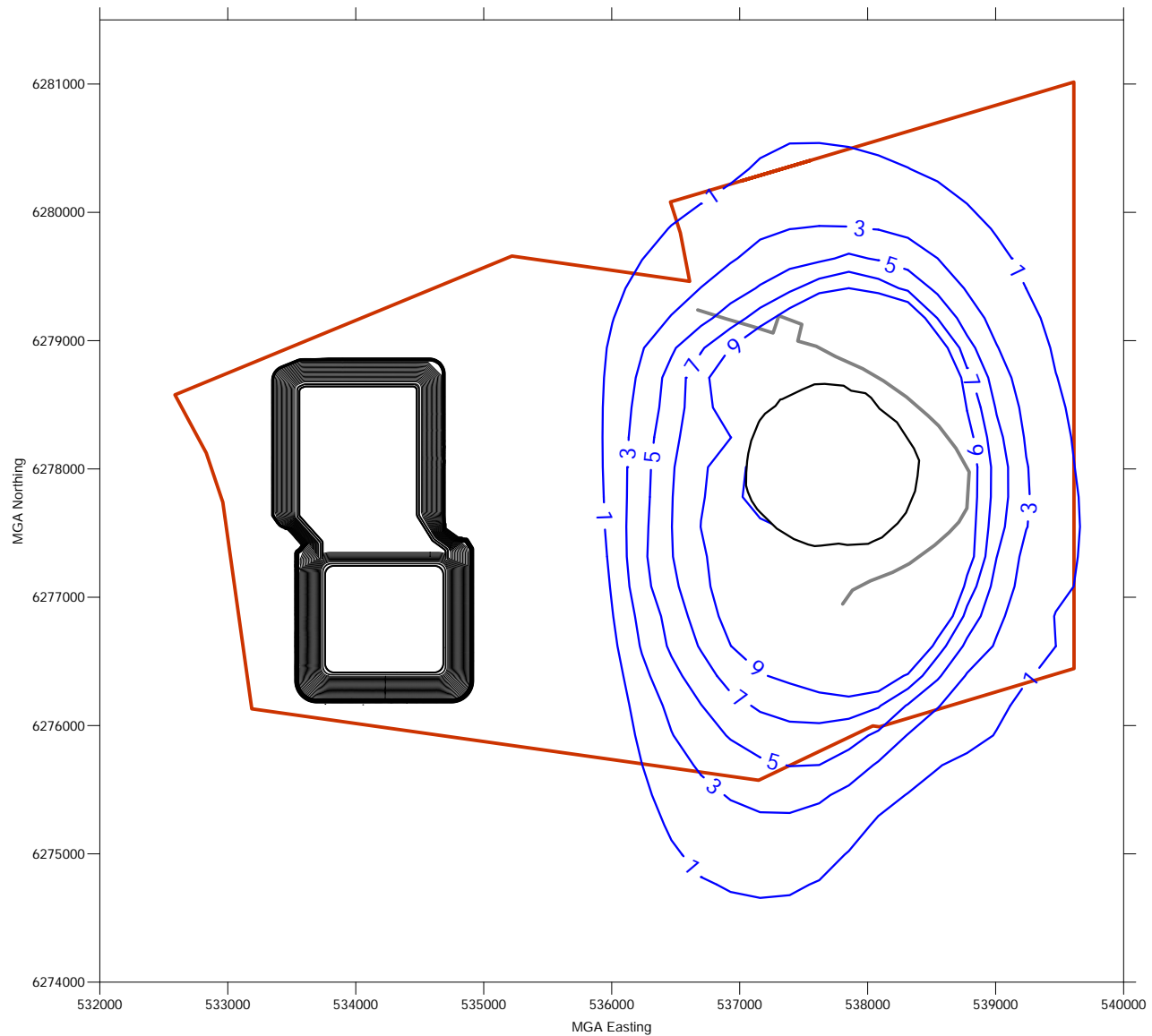

LEGEND

- Approximate Extent of Open Pit
- Lake Protection Bund
- Mine Lease Boundary
- Model Predicted Groundwater Drawdown (m)

| | |
|---------------|-------------|
| drawn | SE |
| approved | RJB |
| date | 02 Nov 2016 |
| scale | 1:50,000 |
| original size | A4 |



| | | |
|-------------|--|-------------------------------|
| client: | EVOLUTION MINING (COWAL) PTY LTD | |
| project: | COWAL GOLD OPERATIONS MINE LIFE MODIFICATION HYDROGEOLOGICAL ASSESSMENT | |
| title: | MODELLED GROUNDWATER DRAWDOWN IN TRANSPORTED UNIT 20 YEARS POST CLOSURE, DRY LAKE | |
| project no: | GEOTLCOV21910BG | figure no: FIGURE A-39 |

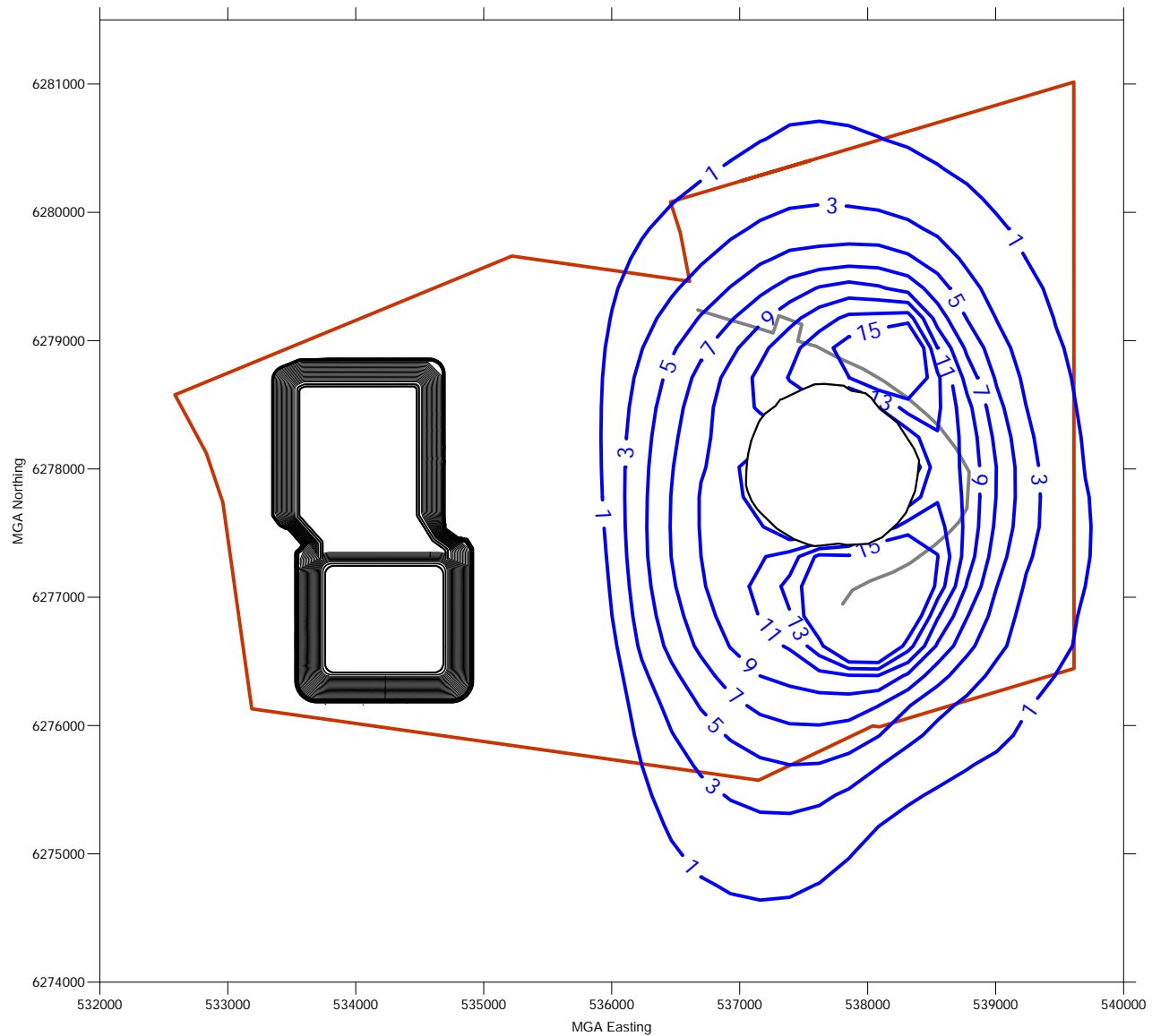

LEGEND

- Approximate Extent of Open Pit
- Lake Protection Bund
- Mine Lease Boundary
- Model Predicted Groundwater Drawdown (m)

| | |
|---------------|-------------|
| drawn | SE |
| approved | RJB |
| date | 02 Nov 2016 |
| scale | 1:50,000 |
| original size | A4 |



| | | |
|-------------|---|-------------------------------|
| client: | EVOLUTION MINING (COWAL) PTY LTD | |
| project: | COWAL GOLD OPERATIONS MINE LIFE MODIFICATION HYDROGEOLOGICAL ASSESSMENT | |
| title: | MODELLED GROUNDWATER DRAWDOWN IN SAPRO-LITE UNIT 20 YEARS POST CLOSURE, DRY LAKE | |
| project no: | GEOTLCOV21910BG | figure no: FIGURE A-40 |

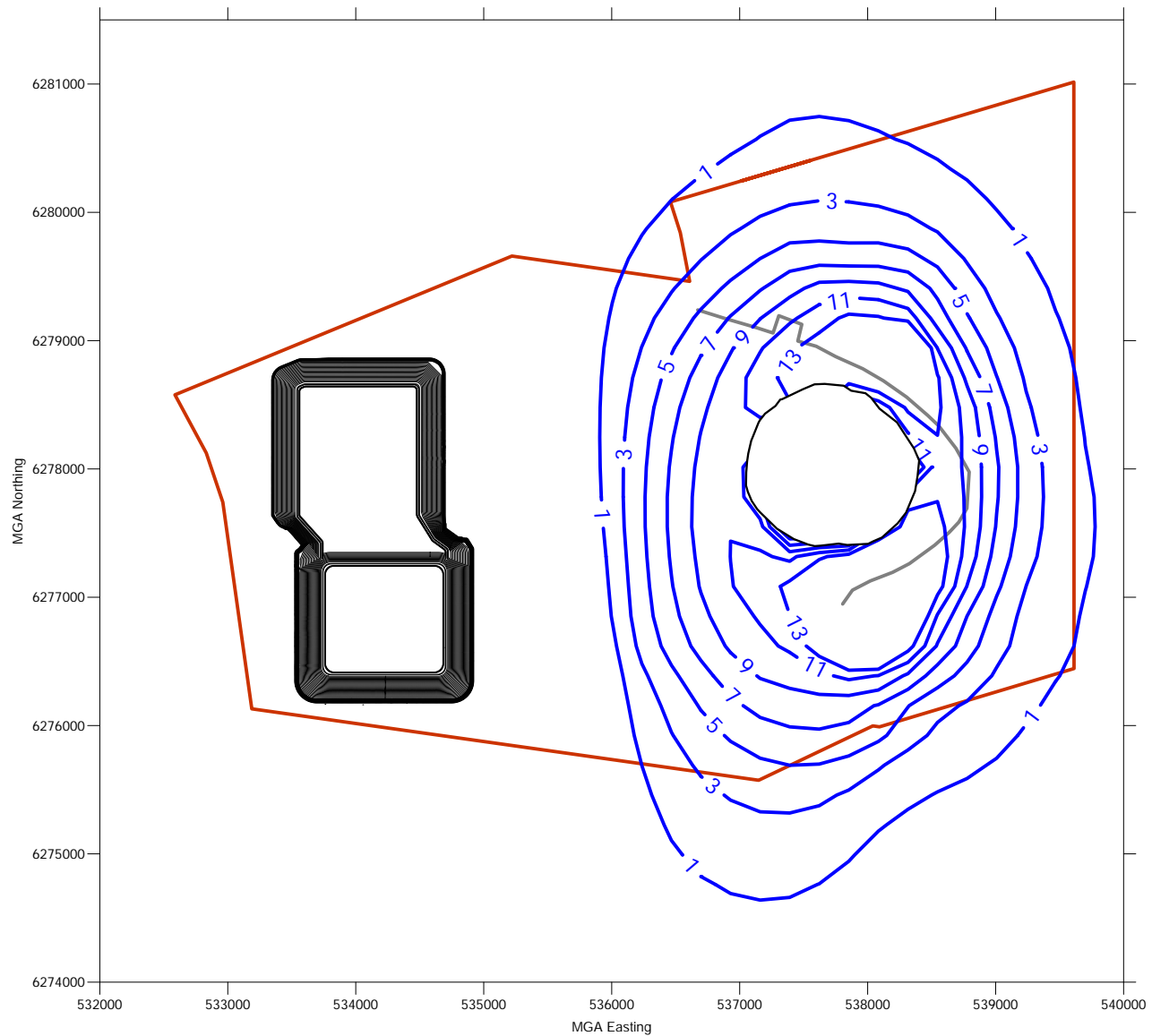

LEGEND

- Approximate Extent of Open Pit
- Lake Protection Bund
- Mine Lease Boundary
- Model Predicted Groundwater Drawdown (m)

| | |
|---------------|-------------|
| drawn | SE |
| approved | RJB |
| date | 02 Nov 2016 |
| scale | 1:50,000 |
| original size | A4 |



| | | |
|-------------|--|-------------------------------|
| client: | EVOLUTION MINING (COWAL) PTY LTD | |
| project: | COWAL GOLD OPERATIONS MINE LIFE MODIFICATION HYDROGEOLOGICAL ASSESSMENT | |
| title: | MODELLED GROUNDWATER DRAWDOWN IN SAPROCK UNIT 20 YEARS POST CLOSURE, DRY LAKE | |
| project no: | GEOTLCOV21910BG | figure no: FIGURE A-41 |

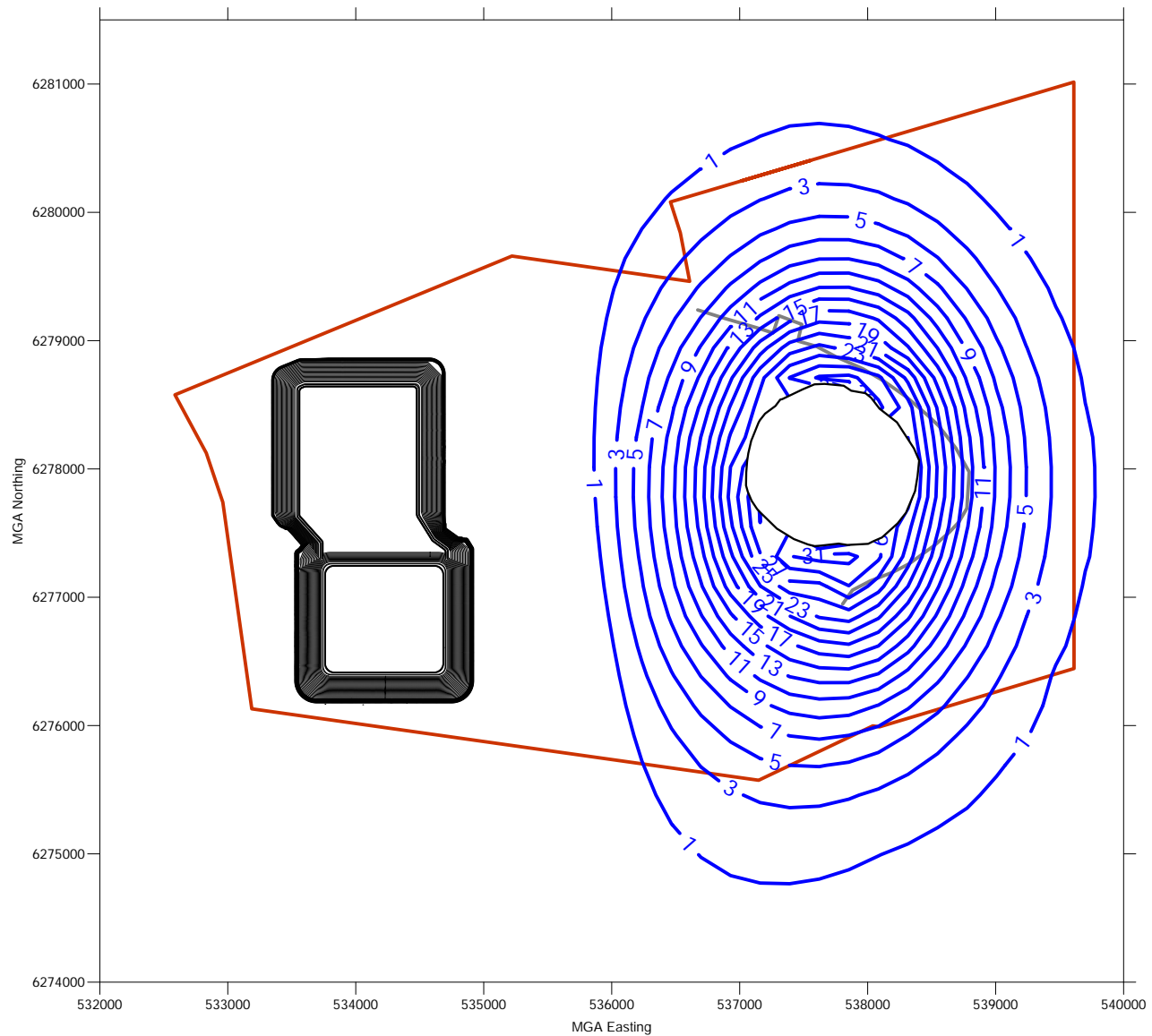

LEGEND

- Approximate Extent of Open Pit
- Lake Protection Bund
- Mine Lease Boundary
- Model Predicted Groundwater Drawdown (m)

| | |
|---------------|-------------|
| drawn | SE |
| approved | RJB |
| date | 02 Nov 2016 |
| scale | 1:50,000 |
| original size | A4 |



| | |
|---|-------------------------------|
| client: EVOLUTION MINING (COWAL) PTY LTD | |
| project: COWAL GOLD OPERATIONS MINE LIFE MODIFICATION HYDROGEOLOGICAL ASSESSMENT | |
| title: MODELLERD GROUNDWATER DRAWDOWN IN PRIMARY ROCK UNIT 20 YEARS POST CLOSURE, DRY LAKE | |
| project no: GEOTLCOV21910BG | figure no: FIGURE A-42 |

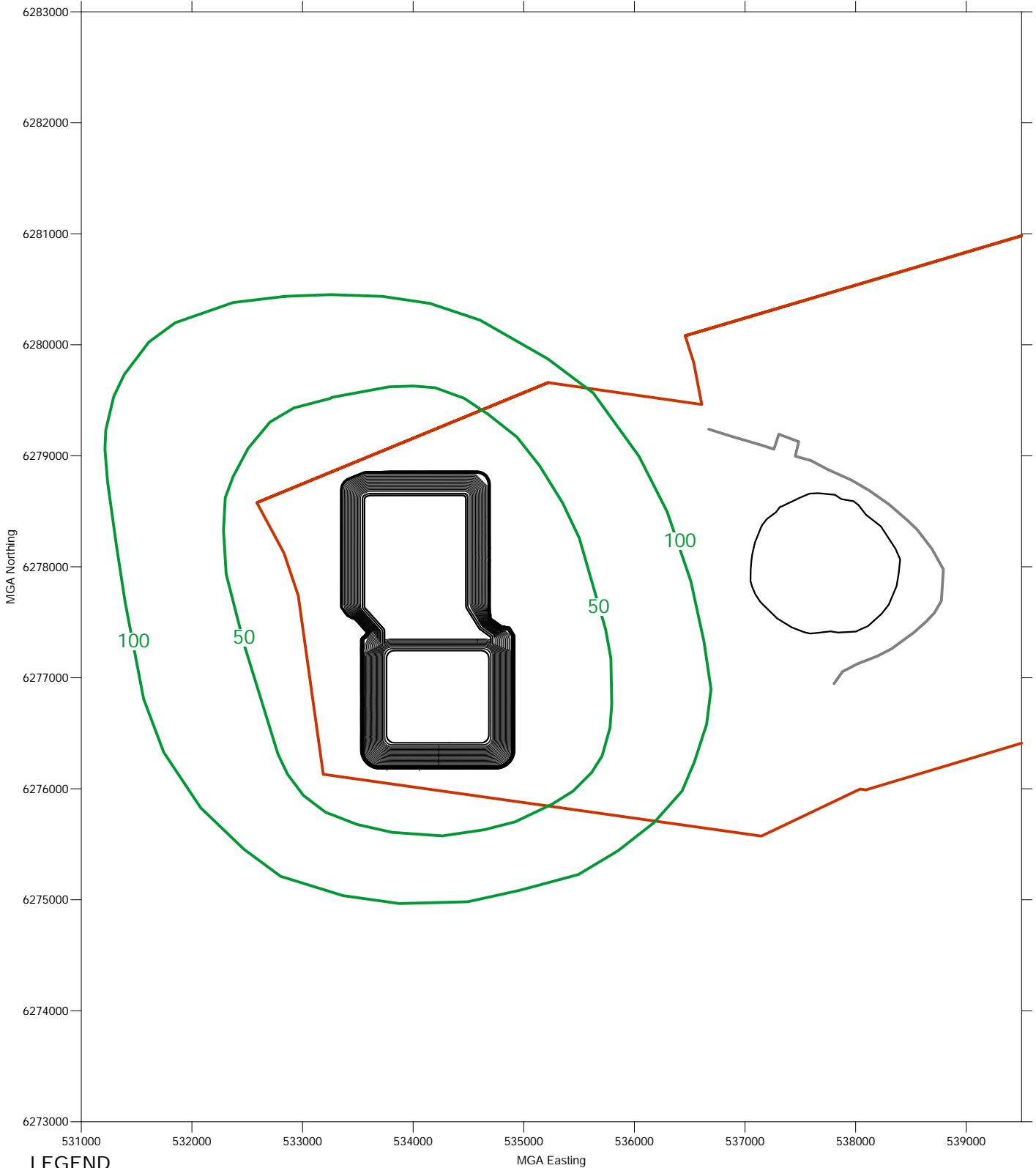

LEGEND

- Approximate Extent of Open Pit
- Lake Protection Bund
- Mining Lease Boundary
- Possible Groundwater Quality Change for Groundwater Released From TSF Wall After Time (Years) Assuming Hydraulic Conditions at Mine Closure

| | |
|---------------|-------------|
| drawn | SE |
| approved | RJB |
| date | 02 Nov 2016 |
| scale | 1:50,000 |
| original size | A4 |



| | | |
|-------------|---|-------------------------------|
| client: | EVOLUTION MINING (COWAL) PTY LTD | |
| project: | COWAL GOLD OPERATIONS MINE LIFE MODIFICATION HYDROGEOLOGICAL ASSESSMENT | |
| title: | PREDICTED EXTENT OF GROUNDWATER QUALITY CHANGE WITH TIME IN SAPROLITE UNIT | |
| project no: | GEOTLCOV21910BG | figure no: FIGURE A-43 |

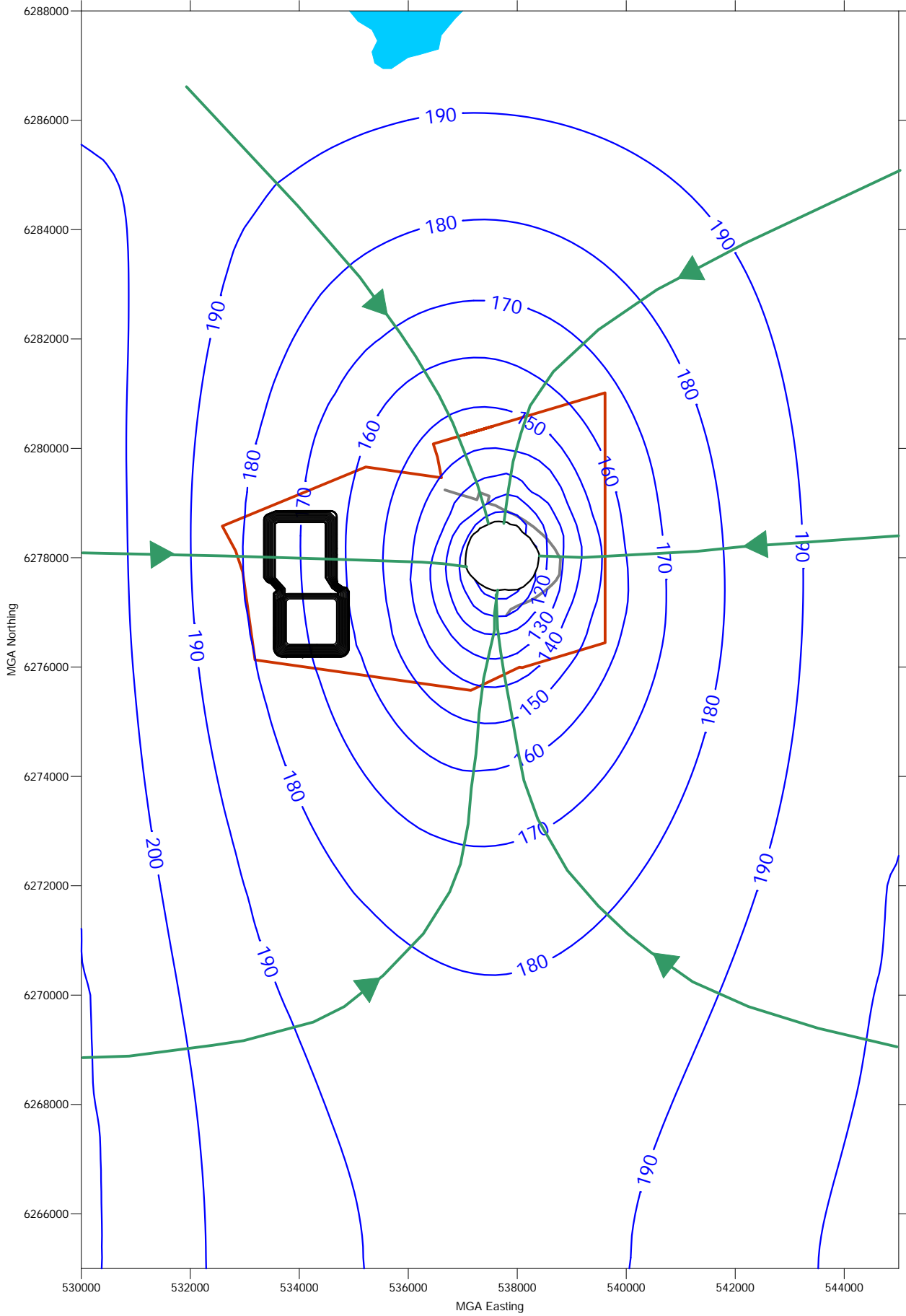

LEGEND

- Approximate Extent of Open Pit
- Lake Protection Bund
- Mining Lease Boundary
- Direction of Groundwater Flow

| | |
|---------------|-------------|
| drawn | SE |
| approved | RJB |
| date | 02 Nov 2016 |
| scale | 1:100,000 |
| original size | A4 |



| | | |
|-------------|--|-------------------------------|
| client: | EVOLUTION MINING (COWAL) PTY LTD | |
| project: | COWAL GOLD OPERATIONS MINE LIFE MODIFICATION HYDROGEOLOGICAL ASSESSMENT | |
| title: | GROUNDWATER CONTOURS AND FLOW DIRECTION IN SAPROLITE UNIT, LONG-TERM, DRY LAKE SCENARIO | |
| project no: | GEOTLCOV21910BG | figure no: FIGURE A-44 |

Evolution Mining (Cowal) Pty Limited

Cowal Gold Operations Mine Life Modification

Bland Creek Palaeochannel Borefield and
Eastern Saline Borefield Groundwater
Assessment

9 November 2016

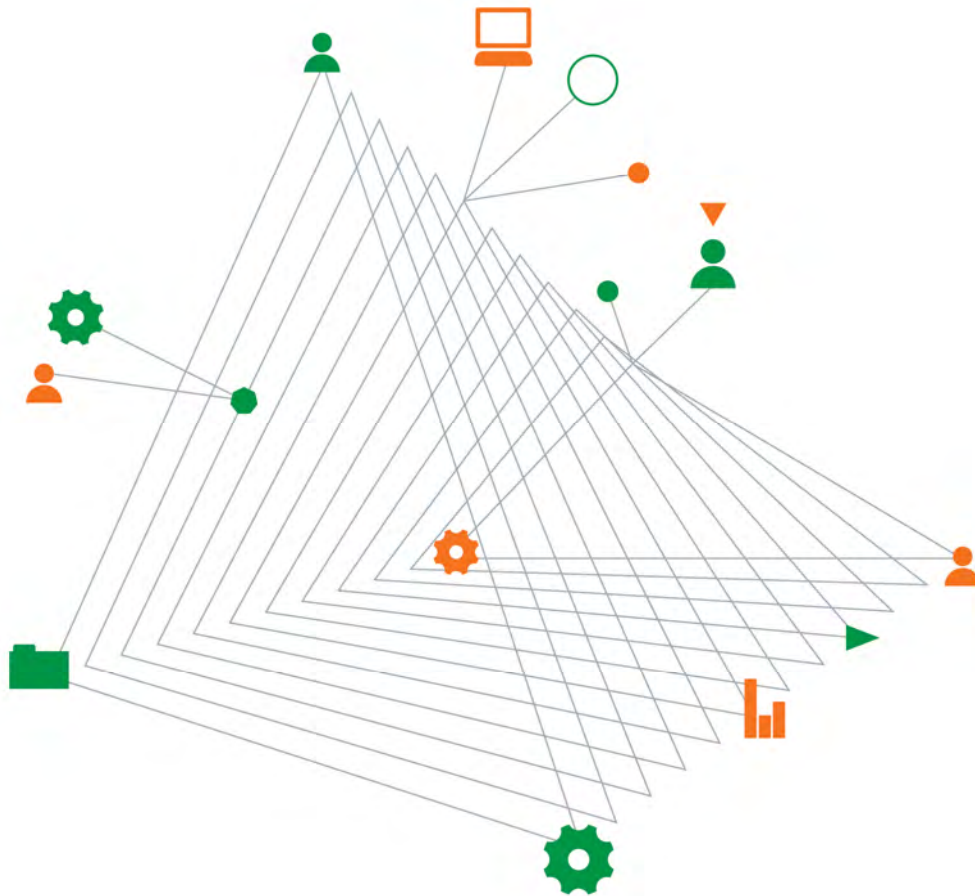

Experience
comes to life
when it is
powered by
expertise

Cowal Gold Operations Mine Life Modification

Prepared for
Evolution Mining (Cowal) Pty Limited
PO Box 210
WEST WYALONG
NSW 2671

Prepared by
Coffey Services Australia Pty Ltd
Level 19, Tower B, Citadel Towers
799 Pacific Highway, Chatswood
NSW 2067 Australia
t: 9406 1000 f: 9406 1002
ABN: 55 139 460 521

9 November 2016

Document authorisation

Our ref: GEOTLCOV21910BG-BCPB

For and on behalf of Coffey



Paul Tammetta
Associate Subsurface Hydrologist

Quality information

Revision history

| Revision | Description | Date | Author | Reviewer | Signatory |
|----------|-------------|------------|---------------|-----------|---------------|
| Final | Final | 9 Nov 2016 | Paul Tammetta | Ross Best | Paul Tammetta |

Distribution

| Report Status | No. of copies | Format | Distributed to | Date |
|---------------|---------------|--------|---|------------|
| Final | 1 | PDF | Clive Berry (Resource Strategies Pty Ltd) | 9 Nov 2016 |

Table of contents

| | |
|--|----|
| Executive summary | 1 |
| 1. Introduction | 2 |
| 1.1. Background | 2 |
| 1.2. Previous Studies | 5 |
| 1.3. Supplied Data | 6 |
| 2. Site Characteristics | 7 |
| 2.1. Topography | 7 |
| 2.2. Climate | 7 |
| 2.2.1. Regional averages | 7 |
| 2.2.2. Mine site rainfall | 8 |
| 2.3. Surface Drainage | 9 |
| 2.3.1. Recharge to the water table | 11 |
| 2.4. Geology | 13 |
| 2.5. Subsurface hydraulic properties | 13 |
| 2.5.1. Hydraulic conductivity | 13 |
| 2.5.2. Storativity | 15 |
| 2.6. Groundwater Levels and Flow | 16 |
| 2.6.1. Monitoring Network | 16 |
| 2.6.2. Hydrographs | 16 |
| 2.6.3. Hydraulic Head Surfaces | 19 |
| 2.6.4. Hydraulic Head Cross-Sections | 19 |
| 2.7. Groundwater Salinity | 23 |
| 2.7.1. Trend Analysis | 25 |
| 2.8. Groundwater Extraction | 26 |
| 2.9. BCPB and ESB usage | 27 |
| 2.9.1. Comparison of actual and planned process water demand | 30 |
| 3. Hydrogeological conceptual model | 31 |
| 4. Numerical model verification | 32 |
| 4.1. Results | 32 |
| 5. Predictive Simulation | 33 |
| 5.1. Simulated Scenarios | 33 |
| 5.2. Private bore pumping | 34 |
| 5.2.1. Inactive pumping bores | 35 |

| | | |
|--------|--|----|
| 5.3. | Results | 35 |
| 5.3.1. | Water level hydrographs | 35 |
| 5.3.2. | Water level drawdown | 39 |
| 5.3.3. | Flow budgets | 40 |
| 5.3.4. | Salinity | 41 |
| 5.3.5. | Post-mining water levels | 42 |
| 6. | Summary and conclusions | 43 |
| 6.1. | Predictive simulation results..... | 43 |
| 6.2. | Regulatory considerations..... | 43 |
| 6.2.1. | Additional allocation for the BCPB | 43 |
| 6.2.2. | Aquifer Interference Policy | 44 |
| 6.2.3. | Lachlan Formation Water Source | 44 |
| 6.2.4. | Cowra Formation Water Source..... | 45 |
| 7. | Limitations | 46 |
| 8. | Recommendations..... | 46 |
| 9. | References | 47 |

Important information about your Coffey Report

Tables

| | |
|-----------|---|
| Table 1. | Average rainfall and pan evaporation in the regional area. |
| Table 2. | High-extraction pumping areas in the regional area. |
| Table 3. | BCPB and ESB groundwater extraction from commencement of borefield operation to 31 August 2016. |
| Table 4. | Diagnostic parameters for correlation of BCPB and ESB usage with rainfall. |
| Table 5. | Actual and planned process water demand. |
| Table 6. | BCPB and ESB future annual pumping schedules for Scenario B (most probable pumping). |
| Table 7. | Private Bore future average annual pumping rates for both predictive scenarios. |
| Table 8. | Drawdown in the Lower Cowra and Lachlan Formations for 31 December 2032 (cessation of BCPB and ESB pumping). |
| Table 9. | Registered private bores screened in the Cowra formation within 15 km of the BCPB and ESB (excluding government and Evolution bores). |
| Table 10. | Flow budgets at the end of BCPB and ESB pumping (31 December 2032). |
| Table 11. | Species transport media properties adopted for simulation of TDS concentrations in the Lachlan Formation for predictive Scenario A. |

Figures

- Figure 1.1. Location of the Cowal Gold Operations.
- Figure 1.2. General arrangement of the Modification.
- Figure 2.1. Correlation of monthly rainfall from the CGO site weather station with two ABM stations for 2004 to 2015 inclusive.
- Figure 2.2. Observed water levels in Lake Cowal and flow at gauge 412103.
- Figure 2.3. Spatial relationship of water table piezometers (maintained by Jemalong Irrigation Limited) classified according to the dominant influence on their hydrographs. Integers at piezometer locations are their names.
- Figure 2.4. K database for the Bland Creek Palaeochannel area.
- Figure 2.5. Hydrographs for approximately coincident piezometers in the BCPB area.
- Figure 2.6. Monitoring piezometer hydrographs for the BCPB.
- Figure 2.7. Monitoring piezometer hydrographs for the ESB.
- Figure 2.8. Interpreted hydraulic head cross-section for December 1997.
- Figure 2.9. Interpreted hydraulic head cross-section for January 2010.
- Figure 2.10. EC of groundwater in the regional area versus depth. Error bars indicate one standard deviation either side of the mean.
- Figure 2.11. Groundwater EC versus time at Evolution monitoring piezometers.
- Figure 2.12. a) Comparison of average EC in the Lachlan Formation at the BCPB, and other trends; b) Correlation of EC and BCPB monthly derivatives.
- Figure 2.13. Correlation of measured BCPB and ESB usage versus rainfall.
- Figure 5.1. Predictive hydrographs for GW036553 for Scenarios A and B.
- Figure 5.2. Predictive hydrographs for ESB PZ02 for Scenarios A and B.
- Figure 5.3. Available monitoring data for GW036597 and GW036611 compared to the cumulative monthly rainfall residual.
- Figure 5.4. Modelled drawdown at GW036597 and GW036611 from BCPB and ESB operation.
- Figure 5.5. Modelled and observed TDS concentrations in the BCPB.

Appendices

- Appendix A - Specific Capacity Analysis
- Appendix B - Groundwater Monitoring Network
- Appendix C – Interpolated Hydraulic Head Surfaces
- Appendix D - Groundwater Electrical Conductivity Averages
- Appendix E - Pumping Bores
- Appendix F - Bland Creek Palaeochannel Numerical Groundwater Flow Model
- Appendix G - Verification Hydrographs
- Appendix H - Drawdown in the Lower Cowra and Lachlan Formations at the end of BCPB and ESB Operation (31 Dec 2032)

Executive summary

A groundwater assessment has been undertaken to assess potential impacts on groundwater levels and quality caused by future groundwater extraction from the Bland Creek Palaeochannel Borefield (BCPB) and Eastern Saline Borefield (ESB) under the proposed Mine Life Modification to the existing Cowal Gold Operations (CGO) operated by Evolution Mining (Cowal) Pty Ltd (Evolution). The assessment employed predictive numerical simulation using an existing numerical groundwater flow model. An assessment of potential impacts on the groundwater system at the mine site has been undertaken using a separate numerical groundwater flow model and is reported separately.

Modelling results indicate that the BCPB can pump at a maximum rate of 5.1 ML/day, from 1 September 2016 to 31 December 2032 (with the ESB pumping at 1.5 ML/day), without causing the water level in trigger piezometer GW036553 to fall to below the contingency trigger level of 134 mAHD.

Under a most-probable predictive scenario (average total pumping from the BCPB and ESB of 4.43 and 0.71 ML/day respectively, between 1 September 2016 to 31 December 2032), the water level in trigger piezometer GW036553 stays above the trigger level during the simulation, except in 2031 (mining year 27) when large tonnages of oxide ore are processed. The lowest modelled water level is 125.0 mAHD. A minor component of the drawdown calculated for GW036553 is caused by other private bores in the area. If the contingency trigger level in trigger piezometer GW036553 is reached during the oxide ore processing in 2031, Evolution may increase the proportion of licensed surface water extractions from the Lachlan River as required to maintain the BCPB groundwater levels above the contingency trigger.

Maximum drawdowns at the end of the CGO are 41 m or less in the Lower Cowra Formation and 70 m or less in the Lachlan Formation. A maximum drawdown of about 32 m (in the Lower Cowra Formation) is modelled for GW029574, the only known water bore installed to a depth within the Lower Cowra Formation and within 15km of the BCPB. However, the bore is 88m deep and may be able to continue operation if the screen length is sufficiently long and optimally located.

Simple numerical transport simulation for the higher pumping rate predictive scenario indicates total dissolved solids concentrations at piezometer BLPR1 will increase by about 20%, by 31 December 2032, from pre-mining concentrations. This compares with an estimated increase of between 12% and 48% calculated in the previous study using a significantly simplified method.

At cessation of BCPB and ESB pumping, groundwater levels at GW036553 are predicted to recover to around 166 mAHD in 10 years (about 30 m below 1998 water levels), and would continue to gradually recover over time, to a level that is dependent on the amount historically pumped, private bore usage following mine closure, and climate.

1. Introduction

This report presents the results of a groundwater assessment of the Bland Creek Palaeochannel Borefield (BCPB) and Eastern Saline Borefield (ESB), both operated by Evolution Mining (Cowal) Pty Limited (Evolution) as water supplies for its Cowal Gold Operations (CGO). The mine is located approximately 38 km northeast of West Wyalong in NSW. The BCPB and the ESB are located approximately 20 km and 10 km east of the CGO, respectively, within the Bland Creek Palaeochannel. Drawing 1 shows the locations of the BCPB and ESB and the CGO mining lease area (with the pit and the tailings impoundments).

The assessment comprised a study of potential impacts on groundwater levels and quality caused by future groundwater extraction from the BCPB and ESB, under Evolution's proposed modification to the current Development Consent (herein referred to as the Modification). The Modification comprises the continuation of open pit mining and processing operations at the CGO for an additional 8 years (to the end of 2032).

An assessment of potential impacts on the groundwater system at the mine site caused by the Modification was undertaken using a separate numerical groundwater flow model and is reported separately.

1.1. Background

Evolution is the owner and operator of the CGO, located approximately 38 km northeast of West Wyalong in New South Wales (NSW) (Figure 1.1). Mining operations at the CGO are approved to 31 December 2024 and are carried out in accordance with Development Consent DA 14/98 (as modified).

Evolution proposes to modify Development Consent DA 14/98 under section 75W of the NSW Environmental Planning and Assessment Act, 1979 (EP&A Act) to facilitate the continuation of open pit mining and processing operations at the CGO for an additional 8 years (to the end of 2032). The main activities associated with development of the Modification would be as follows (refer to Figure 1.2):

- Increasing the final depth of the open pit by 70 m to enable mining of additional ore and an increase in total gold production.
- Extending the life of the approved CGO by up to 8 years, to 31 December 2032.
- Upgrades to the existing leach circuit within the processing plant to improve gold recovery.
- Increasing the total life of mine ore production/volume of tailings and mined waste rock.
- Maximising tailings storage capacity of the existing tailings storage facilities (TSFs) via additional lifts and converting the area between the existing TSFs into a new storage area.
- Incorporation of a rock fill buttress cover on the outer slopes of the TSF embankments to provide long-term stability.
- An increase to the TSF embankment lift fleet.

Cowal Gold Operations Mine Life Modification
BCPB and ESB Groundwater Assessment

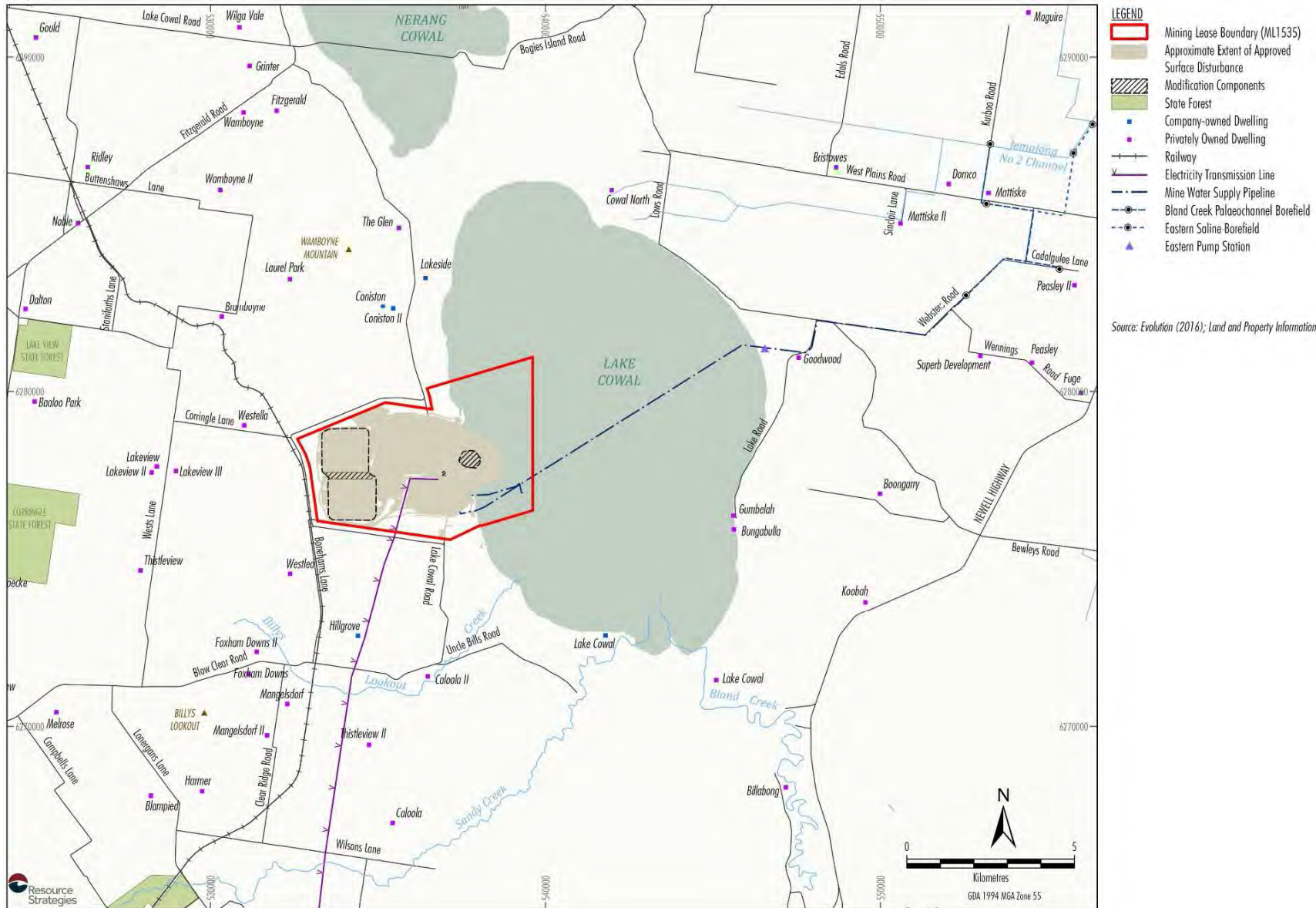

Figure 1.1. Location of the Cowal Gold Operations.

Coffey Services Australia Pty Ltd
GEOTLCOV21910BG-BCPB
9 November 2016

Cowal Gold Operations Mine Life Modification
BCPB and ESB Groundwater Assessment



Figure 1.2. General arrangement of the Modification.

Coffey Services Australia Pty Ltd
GEOTLCOV21910BG-BCPB
9 November 2016

The Modification would involve no change to the following key components of the existing CGO:

- Mining tenement.
- Lake isolation system.
- Existing/approved surface development extent of the CGO.
- Water management system and design objectives.
- Mining methods.
- Ore processing rate.
- Waste rock emplacement disturbance areas.
- Cyanide destruction method.
- Approved cyanide concentration limits in the aqueous component of the tailings slurry.
- Water supply sources.
- Approved daily or annual extraction limits of the BCPB.
- Site access road.
- Power supply.
- Exploration activities.
- Average or peak annual employment.
- Hours of operation.
- TSF embankment construction hours of 7.00 am to 6.00 pm.

1.2. Previous Studies

In 2006, Coffey Services Australia Pty Ltd (Coffey) developed a 3-dimensional numerical groundwater flow model for assessing the impacts of pumping from the BCPB on the surrounding environment and other groundwater users (Coffey 2006), which was calibrated and used for predictive analysis. In 2010, due to changes in the mine plan and the introduction of the ESB, the model was upgraded and used to assess the impacts from proposed future changes in pumping from the BCPB and ESB. The 2010 upgrade comprised the following:

- Division of the Cowra formation into two model layers (the Upper and Lower Cowra Formations), making a 3-layer model (with the bottom layer representing the Lachlan Formation as before), so that pumping from the Cowra Formation could be simulated in more detail.
- Inclusion of the ESB (production bores SB01 and SB02).

Because of the inclusion of an additional layer in the model, and also to ensure that the model is continually updated, the model was recalibrated at the time of the upgrade. This task included the addition of new pumping and monitoring records collected since 2006.

The most recent predictive numerical simulation for the BCPB of potential impacts on the groundwater system was undertaken in 2013 (Coffey 2013).

The work undertaken in the current study uses the existing recalibrated model to simulate potential impacts on the groundwater system from operation of the BCPB and ESB under the Modification. It incorporates additional BCPB pumping measurements, and additional monitoring piezometer measurements, collected between 2013 and 2016. Refer to Coffey 2013 for a detailed description of the numerical model and the recalibration undertaken in 2010.

1.3. Supplied Data

For the purpose of the current study, Evolution supplied the following information:

- Usage for the BCPB and ESB to 31 August 2016.
- Measured water levels and field electrical conductivity from the Evolution BCPB monitoring piezometer network (BLPR1 to BLPR7) to 31 August 2016.
- Measured water levels and field electrical conductivity from the Evolution ESB monitoring piezometer network (PZ01, PZ02, PZ05 to PZ11, and SB03 to SB05) to 31 August 2016.
- Rainfall measured at the CGO site weather station, to 31 August 2016.
- The ore processing schedule for the CGO for 2017 to 2032 inclusive.

Coffey sourced the following data:

- Automatically recorded water levels at government monitoring piezometers GW036553, GW036597, and GW036611, from the NSW Office of Water (NSWOW) internet-based data delivery system.
- Daily rainfall over the period of record for Australian Bureau of Meteorology (ABM) rainfall stations 50017 and 73054, from the ABM internet-based data delivery system.

2. Site Characteristics

2.1. Topography

The region is characterised by a flat landscape with low undulating hills and occasional rocky outcrops. The majority of vegetation in the area has been cleared, with most of the cleared areas used for agriculture. Remnant and secondary vegetation is restricted to elevated rocky areas (SNC Lavalin Australia 2003).

Drawing 1 shows the topography and drainage of the area. Ground slopes fall from the northeast (Lachlan Floodplain) and southeast (upper Bland Creek Palaeochannel) towards Lake Cowal. Lake Cowal forms a local depression and fills with flood water every few years. It drains northwest towards Nerang Cowal, and eventually to the Lachlan River. Breakout flows from the Lachlan River at Jemalong Gap drain towards Lake Cowal.

Ground elevations at the mine site range from around 225 mAHD on the western lease boundary to about 200 mAHD at the eastern lease boundary within Lake Cowal. The BCPB area has an elevation of just under 210 mAHD, with minimal variation. Hills formed by rock outcrops on the fringes of the Bland Creek floodplain reach to in excess of 300 mAHD.

2.2. Climate

2.2.1. Regional averages

The closest rainfall station to the study area with long-term records is ABM Station 73054 (Wyalong Post Office), located south of the mine lease, in the western part of the Bland Creek Palaeochannel. The closest climate station within 100 km of the site with reasonable amounts of pan evaporation data is ABM station 73038 (Temora Research Station), located about 60 km away. Table 1 lists average rainfall at station 73054 and average monthly pan evaporation at station 73038. For average conditions, a rainfall deficit occurs for all months of the year except June and July.

Table 1. Average rainfall and pan evaporation in the regional area.

| Month | Mean rainfall (mm) at Wyalong Post Office (73054) | Mean pan evaporation (mm) at Temora Research Station (73038) |
|-----------|---|--|
| January | 41 | 270 |
| February | 39 | 220 |
| March | 38 | 183 |
| April | 35 | 108 |
| May | 39 | 62 |
| June | 44 | 36 |
| July | 42 | 40 |
| August | 39 | 56 |
| September | 37 | 87 |
| October | 45 | 136 |
| November | 37 | 195 |
| December | 44 | 245 |
| Annual | 479 | 1644 |

2.2.2. Mine site rainfall

Daily rainfall data are available for the period 2004 to 2015 inclusive from the CGO site weather station. The monthly site rainfall has been correlated with annual rainfall from ABM stations 73054 (Wyalong Post Office) and 50017 (West Wyalong Airport). The latter two stations have also been correlated against each other for the same years. Figure 2.1 illustrates the correlations.

Figure 2.1. Correlation of monthly rainfall from the CGO site weather station with two ABM

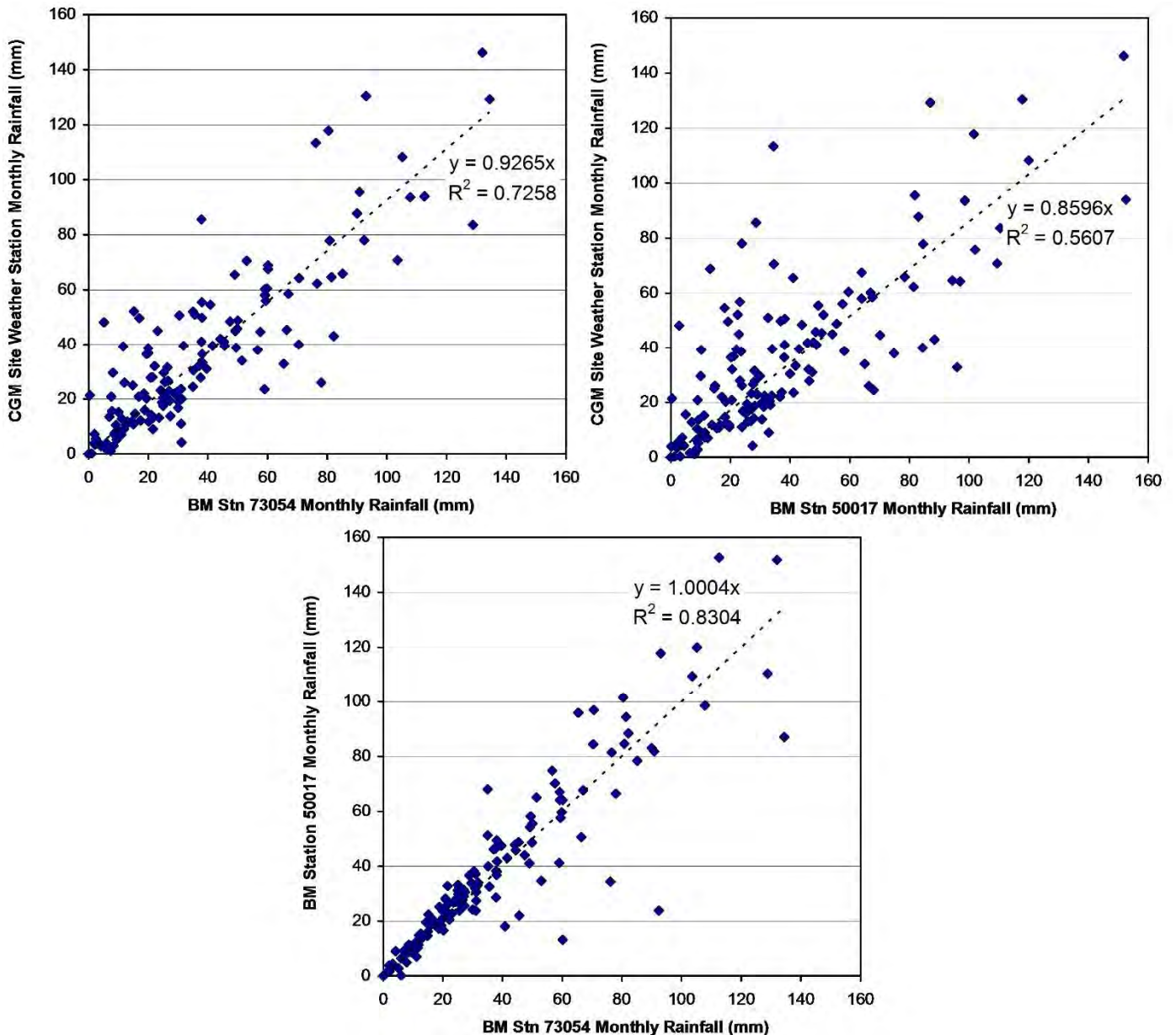

stations for 2004 to 2015 inclusive.

CGO site rainfall correlates reasonably with 73054 but less so with 50017. The residuals normality for 50017 with the CGO site and 73054 is poor. CGO site monthly rainfall is an average of 93% of 73054 rainfall. By corollary, the long-term average rainfall at the CGO site is estimated to be 444 mm.

2.3. Surface Drainage

The main water courses in the BCPB area are Bland and Barmedman Creeks (Drawing 1). These are ephemeral and drain into Lake Cowal, also ephemeral, flowing into it from the south. An extensive irrigation canal system is also present at the BCPB area and to the north. These canals deliver water to irrigators to sustain the local agricultural industry.

Flow gauging data from government flow gauge 412103 (Bland Creek at Morangarell) were available for the period 1976 to 2003. This gauge has a catchment area of 3,110 km² and is located in the Burragorang Palaeochannel, about 10km south of the southern boundary of the modelled area (see Drawing 1). A review of the flow data for this period indicate the following:

- No flow for 61% of the period (the minimum measurable flow is 0.1 ML/day).
- An average flow over all days of 117 ML/day.
- An average flow over all days of measurable flow (39% of the period) of 298 ML/day.
- A maximum recorded flow of 17,854 ML/day (on 27 July 1993).

A baseflow analysis was undertaken for flow data from gauge 412103 using the local minimum method, implemented using the program BFI and the procedure of Wahl and Wahl (1995). This implementation is based on the deterministic procedure proposed by the British Institute of Hydrology (1980a, 1980b). Using this method, baseflow is estimated by analysing the minima in streamflow time series when partitioned into N-day periods. Unlike filtering methods, the local minimum method cannot calculate baseflows that are greater than streamflow, and makes no assumptions about recession character. Based on experience, and the preferred use of the method by overseas agencies, this method is considered superior to filtering for extraction of baseflow magnitudes. Results of the analysis indicate that baseflow was an average of 0.3% of rainfall between 1977 and 2000.

Lake Cowal is an ephemeral shallow freshwater lake that is filled by runoff from the Bland Creek catchment to the south and flood breakout from the Lachlan River to the northeast. The pit envelope impedes on the lake area and a pit protection bund and dewatering programme form an integral part of the mine plan. At the overflow (full storage) level of about 205.7 mAHD the lake overflows into Nerang Cowal, another ephemeral lake to the north, and then into Bogandillon Swamp before returning to the Lachlan River. The base of the lake is at about 201.5 mAHD. Figure 2.2 shows available lake water level observations compared to flow at gauge 412103. When the lake is draining, water levels show a quasi-logarithmic fall. Below the full storage level, the rate of water level fall is approximately linear with time. An analysis of eight recession events was undertaken. For each event, the time period was selected such that other data suggest negligible inflows to the lake from creeks and surface runoff were occurring. For each event, pan evaporation and direct rainfall to the lake water body were taken into account. The average fall in lake water level (accounting for rainfall) from the events was equal to 80% of pan evaporation. This is similar to recorded rates of water level fall for large shallow lakes that contain suspended and dissolved solids in a semi-arid climate. Results indicate that transfer of groundwater to or from Lake Cowal is low, with the precision of the results being less than that required to quantify the transfer.

Irrigation canals are extensive and most of their combined reach appears to be unlined. These channels serve as artificial water courses to deliver water for local agriculture but are ephemeral (they are mainly use during the growing season). One of the main channels in the area (the Warroo channel) has been reported as suffering losses through seepage from the channel base (van der Lely, 1993), estimated at around 2000 ML/year but potentially ranging between 500 and 6000 ML/year.

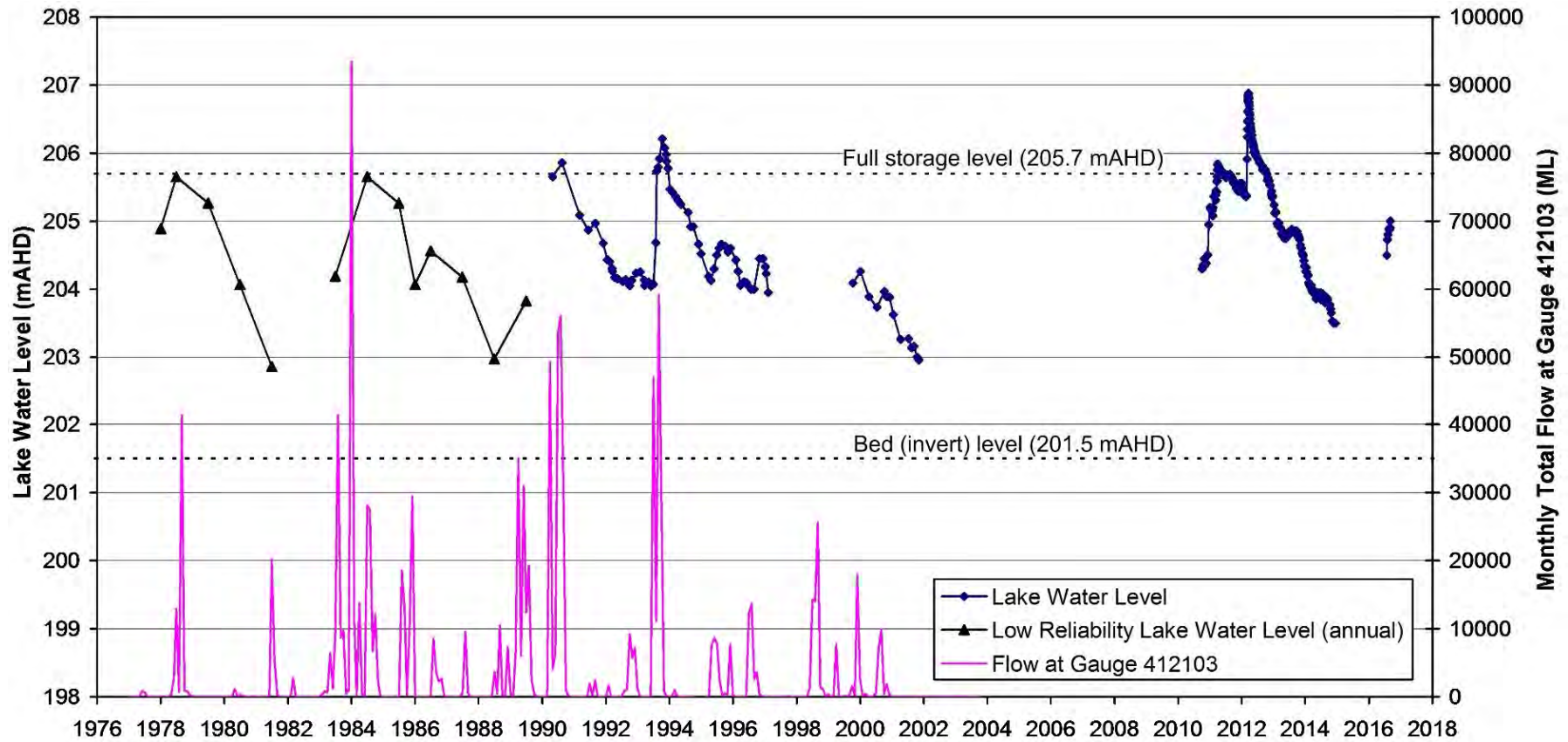

Figure 2.2. Observed water levels in Lake Cowal and flow at gauge 412103.

2.3.1. Recharge to the water table

Studies of groundwater chemistry in the Bland Creek palaeochannel (Carrara et al, 2004) indicate that the Thuddungra region is a recharge area for the Lachlan and Cowra Formations (Carrara et al, undated). Results also suggest that the Lachlan Formation shows a generalised preferential lateral groundwater flow system, without significant vertical recharge except in the Thuddungra region. In contrast, results suggest that the shallow part of the Cowra Formation comprises a system where recharge to the groundwater system is dominated by vertical infiltration at the surface, and lateral groundwater flow is limited and local.

Anderson et al. (1993) estimated that recharge through the base of stream channels and over-bank flooding are the dominant recharge processes in the Lachlan Valley. The amount of recharge provided by this process in the Bland Creek Palaeochannel is difficult to assess due to impact of pumping on groundwater monitoring hydrographs. Minor flooding occurs intermittently in the palaeochannel area however surface sediments in this area are less permeable than further north in the Jemalong / Wyldes Plains Irrigation District and the main Lachlan Valley, likely resulting in lower recharge from this source compared to the Lachlan Valley.

Coffey (1994b) estimated a total accession rate (irrigation deep drainage and rainfall infiltration) to the groundwater system, from numerical model calibration, of between nil and 18 mm/year for the Upper Cowra Formation in the Jemalong / Wyldes Plains Irrigation District. The higher infiltration rates were restricted to a 10km-wide zone south of the Lachlan River. The overall average calibrated recharge to the Upper Cowra Formation between Lake Cowal and the Lachlan River was around 10mm/year or around 2% of average rainfall.

Ross (1982) estimated that 1.25% of rainfall accedes to the groundwater system in the low salinity groundwater areas of the upper Lachlan Valley.

Williams (1993) estimated that long-term increases in groundwater storage in the Upper Cowra Formation in the Jemalong / Wyldes Plain Irrigation District were a minimum of about 5.2 mm/year (about 1% of incident rainfall, assuming a refillable void space of 5% at the water table). Results did not allow separate identification of contributions made by flooding, rainfall, and irrigation.

Cook et al (2001) estimated rainfall recharge over agricultural land of the Mallee region near the Murray River (average rainfall 300 to 400 mm/year). Results indicated deep drainage rates varying between 3 mm/year (0.9% of annual rainfall) and 30mm/year (9% of annual rainfall) at crop rotation sites with average clay contents in the upper 2m of the surface soil profile varying between 30% and 2% respectively.

Numerical modelling by Williams (1993) for the upper 20m of the Cowra Formation indicated that evaporation from surface ponding caused by groundwater seeps was occurring in several locations in the more topographically depressed area in the vicinity of the Corinella Constriction.

Hydrograph Analysis for the BCPB Area

With the area characterised by high rates of irrigation, an assessment was undertaken for the area east of Lake Cowal to estimate zones where recharge to the water table is likely to be controlled mainly by rainfall or mainly by irrigation. This was the only area in the model domain where significant amounts of water table hydrographs were available (from monitoring piezometers maintained by Jemalong Irrigation Limited, for the period 1994 to 2006).

The assessment compared piezometer hydrographs to the cumulative monthly rainfall residual. Hydrographs showing a significant correlation with the rainfall residual were classified as being influenced mainly by rainfall. Irrigation may still have been active in these areas, however its influence was interpreted as secondary. Hydrographs showing a characteristic trend of rise during dry conditions were classified as irrigation-dominated.

Figure 2.3 shows the results of the assessment. Piezometer names are a single number. The pattern identifies the area where irrigation is affecting the water table. Recharge will thus vary across the area. Areas with irrigation-dominant recharge may have larger groundwater recharge. The numerical model adopts a single average rate which takes into account the irrigation process, however further south there are fewer tracts of land that are irrigated. Irrigation practices add a degree of approximation to the recharge rate used in the model.

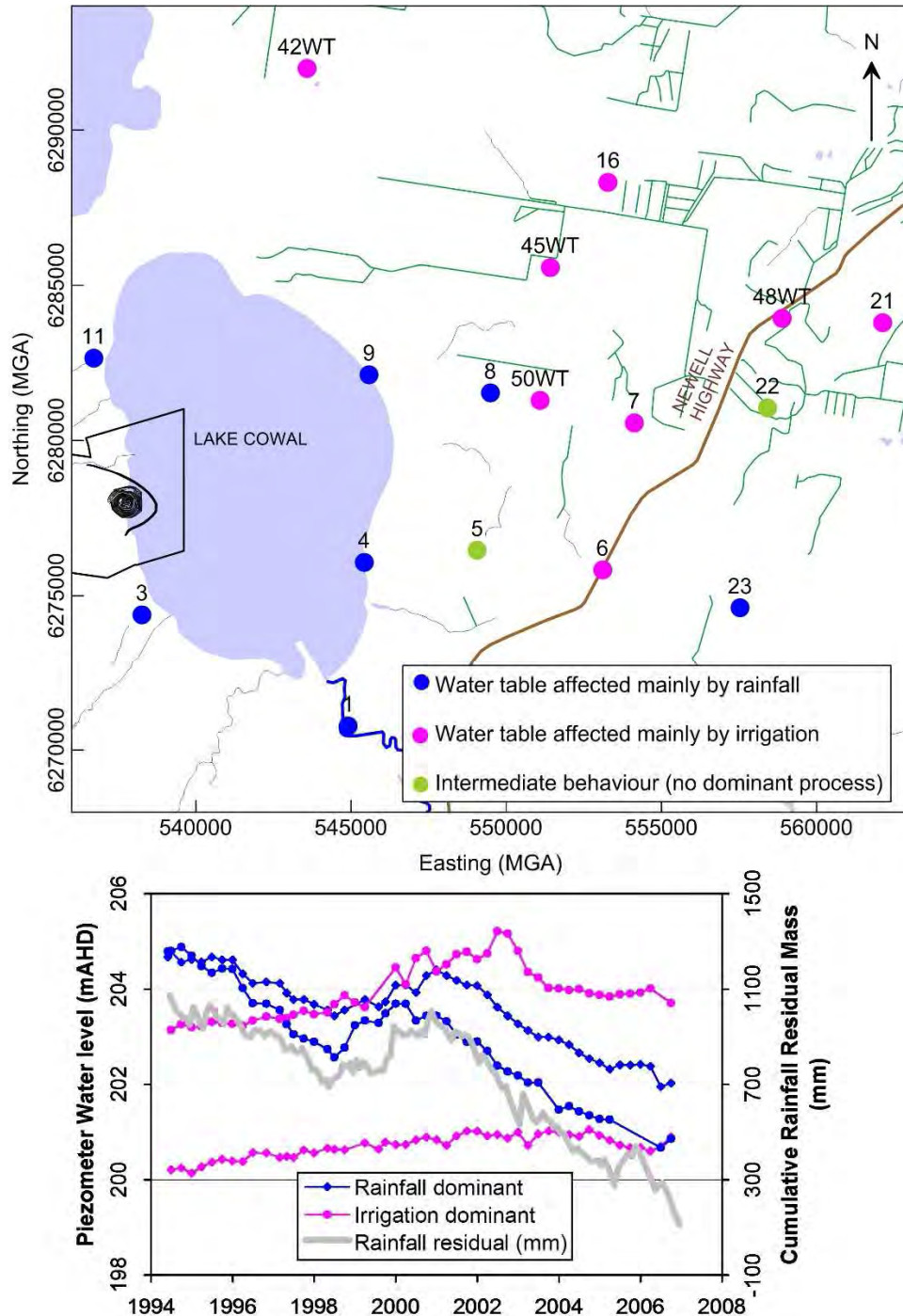

Figure 2.3. Spatial relationship of water table piezometers (maintained by Jemalong Irigation Limited) classified according to the dominant influence on their hydrographs. Integers at piezometer locations are their names.

2.4. Geology

A detailed discussion of the geology of the area is made in Coffey (2013). A summary is provided below.

The alluvial sequence in the study area consists of the Cowra Formation and the underlying Lachlan Formation. The Lachlan Formation is the main aquifer in the study area. The Cowra Formation has lower hydraulic conductivity (K) and higher groundwater salinity.

The Cowra Formation comprises predominantly stiff red/yellow/brown high plasticity clay (grading to grey at depth) with intermittent sand and silt horizons. The base of the Cowra formation is generally marked by a conspicuous multi-coloured clay layer. Geophysical (gamma) logs and hydraulic test data for bores in the vicinity of the BCPB suggest that the Cowra Formation can be divided into upper and lower sequences. The base of the Upper Cowra sequence is assessed to be at about 47m below ground level.

The Lachlan Formation consists of light grey fine to coarse-grained sand and fine to medium gravel, mostly composed of smoky quartz, chert, and wood fragments. The Lachlan Formation is underlain by bedrock. Between 2m and 5m of clay lies between the base of high K sediments in the Lachlan Formation and the top of bedrock, however in some places the clay is absent. The clay is interpreted to mostly consist of residual weathered product of underlying rocks. The modelled extent of the Lachlan Formation includes lower K sediments surrounding the high permeability sands and minor gravels in the deeper parts of the palaeochannel. The high K sands and minor gravels appear to be located adjacent to steep bedrock surface gradients within the deeper parts of the palaeochannel. The spatial variation in high and low conductivity sediments in the Lachlan Formation indicates that the high conductivity part of the Lachlan Formation bifurcates just north of Marsden.

A constriction in the bedrock surface occurs to the north of the BCPB at Corinella, and is referred to as the Corinella Constriction.

2.5. Subsurface hydraulic properties

2.5.1. Hydraulic conductivity

For previous studies, a large database was compiled of K measurements from insitu hydraulic testing. The database consists of the following:

- 26 single rate pump tests conducted on the mine lease.
- 3 packer tests in volcanic rocks conducted on the mine site.
- 2 long term single rate pump tests conducted at the two saline borefields (one at each borefield).
- 6 long-term single rate tests conducted at the BCPB.
- 102 estimates of K from specific capacity data in government records for private water bores. 45 estimates are for the Lachlan Floodplain (north of the Corinella Constriction). Appendix A shows the method used to obtain K from specific capacity.

Figure 2.4 shows the K database developed from these measurements.

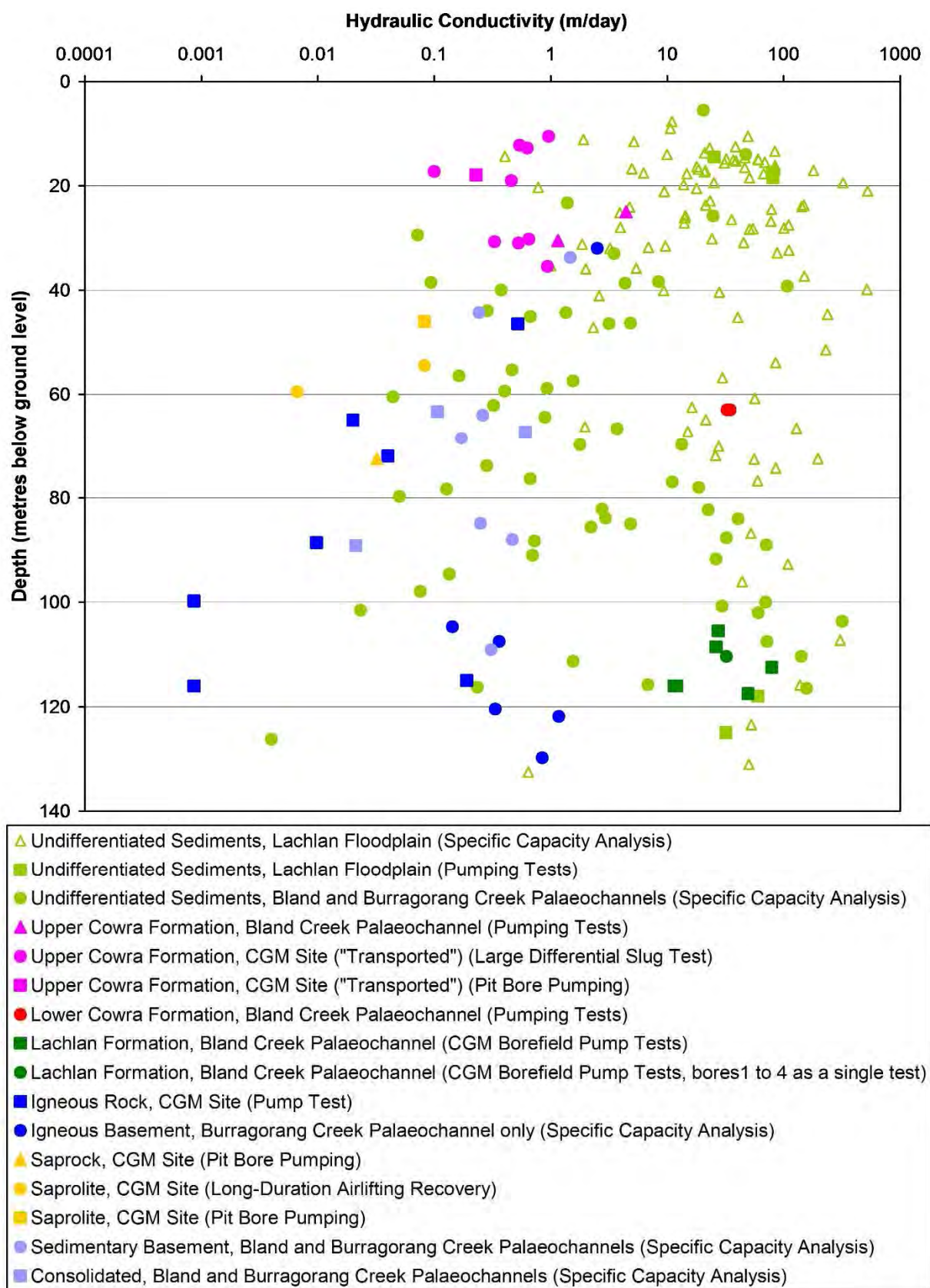

Figure 2.4. K database for the Bland Creek Palaeochannel area.

Three distinct alluvial sequences are interpreted to be present. These are as follows:

- Upper Cowra Formation. This sequence generally occurs from ground surface to an average depth of around 45 m to 50 m. The average depth to groundwater is around 7m, giving an average saturated thickness of just over 40m. This sequence generally shows decreasing K with depth.
- Lower Cowra Formation. This sequence generally occurs over an average depth interval of around 50m to 90m over most of the study area. This layer appears to have different hydraulic properties to the Upper Cowra formation.
- Lachlan Formation. This sequence generally occurs over an average depth interval of around 90m to 120m in the Bland Creek Palaeochannel and between 75m and 110m in the Burragorang Palaeochannel. Within this formation two distinct sequences are interpreted as follows:
 - High K sands and minor gravels close to and within the deeper parts of the palaeochannel. This sequence has a geometric mean K of about 30 m/day.
 - Lower K sediments generally occurring further away from the deeper parts of the palaeochannel and surrounding the high K sands and minor gravels. The hydraulic properties of this sequence appear similar to the Lower Cowra Formation.

The Bland Creek Palaeochannel basement consists mostly of sedimentary sequences (at burial depths exceeding 100m). Igneous basement is present in the upper reaches of the Burragorang Palaeochannel. At the mine site, hydraulic conductivity of weathered and fresh rock follows a pattern of decreasing K with depth. Saprolite retains some of the original rock structure and can host open defects. The high K parts of the Lachlan Formation have a K about 100 to 1000 times larger than underlying bedrock. Bedrock at depth in the study area is considered to have significantly lower K than unconsolidated sediments except in structurally disturbed areas.

The bed of Lake Cowal is composed of a lacustrine clay layer of between 3m and 8m thickness. Hawkes (1998) reports an average vertical K of 5×10^{-7} m/day for the clay, from laboratory measurements on 7 samples, and an average horizontal K of 6×10^{-5} m/day from three insitu hydraulic tests. However, many boreholes have been drilled in the lake (Hawkes, 1998), penetrating the clay into underlying gravels of the Upper Cowra Formation. The status of reinstatement at these drilling locations is unknown.

2.5.2. Storativity

No hydraulic test data were available from which an assessment of the specific yield of the Cowra Formation could be made. Williams (1993) estimated a value of 5% for the refillable void space at the water table in the Upper Cowra Formation in the Jemalong Plains Irrigation District. Surface sediments in that district are known to have a higher K than surface sediments in the Bland Creek Palaeochannel.

Results from hydraulic tests undertaken in 2004 in BCPB bores indicate an average storativity of 1.9×10^{-4} for the Lachlan Formation (Groundwater Consulting Services Pty Ltd (GCS) 2006). A pump test of seven days duration conducted at BLPR2 in 1995 (Coffey 1995b) indicated an average storativity of 1.7×10^{-4} for the Lachlan Formation. Assuming that confined processes provided the dominant influence on drawdowns during these tests (minimal drainage at the water table during the tests), the storativities are approximately equivalent to average specific storages of $9.5 \times 10^{-6} \text{ m}^{-1}$ and $8.5 \times 10^{-6} \text{ m}^{-1}$ respectively.

2.6. Groundwater Levels and Flow

2.6.1. Monitoring Network

Groundwater levels in the BCPB and ESB areas are monitored by Evolution using a network of standpipe piezometers as follows:

- BCPB: Piezometers BLPR1 to BLPR7.
- ESB: Piezometers PZ01 (decommissioned in 2012), PZ02, PZ05 to PZ11, and future pumping bores SB03 to SB05.

For the ESB piezometers, screen intervals for PZ06 to PZ08 are unknown. In the early stages of ESB development, conflicts in observation piezometer nomenclature, and use of two map grid systems, occurred; for the current work, best estimates were made for screen intervals for PZ01, PZ02, and PZ05, based on matching of coordinates, similarity of completed depths, and other information.

The NSW Office of Water (NSWOW) and Jemalong Irrigation Limited (JIL) also maintain extensive networks of standpipe monitoring piezometers in the area for various purposes.

Water level observations from the Evolution piezometers, and a selection of NSWOW and JIL piezometers, have been used in previous studies for assessment of the hydraulic head field, and numerical model calibration and verification. In selecting NSWOW piezometers, the following criteria were generally applied, to reduce the potential for unrepresentative measurements:

- Backfilling of 20m or less from the base of the borehole to the bottom of the screen.
- Screens placed in separate boreholes.

Where multiple screens were installed in a single borehole, only the lowermost standpipe was selected, subject to the backfilling criterion and other factors.

The resulting network comprises 45 measurement points at 38 locations. Appendix B lists these piezometers and contains a map showing their locations. NSWOW monitors high-rate groundwater extraction in the area at piezometers GW036553, GW036597, and GW036611. These are fitted with automatic water level recorders.

For the current work, monitoring data from NSWOW and JIL piezometers, and private water bores, were unavailable. Coffey sourced recorded water levels at NSWOW piezometers GW036553, GW036597, and GW036611, from the NSWOW internet-based data delivery system. The following sections summarise salient features of the hydraulic head field since before CGO operations commenced, using available information.

2.6.2. Hydrographs

Figure 2.5 shows hydrographs for the Upper Cowra, Lower Cowra, and Lachlan Formations in the BCPB area, using an approximately coincident set of monitoring piezometers throughout the vertical profile. They illustrate propagation of depressurisation at depth up through the profile. Increased groundwater extraction from the Lachlan Formation can be seen from the beginning of the drought in the 2000s. The vertical anisotropy of the sediments limits the upward propagation of depressurisation in the Lachlan Formation. The water table appears to remain unaffected over most of the record, however in this area, high volumes of irrigation are applied to the ground surface. The higher conductivity of the Lachlan Formation allows depressurisation from pumping to travel extensively in the lateral direction.

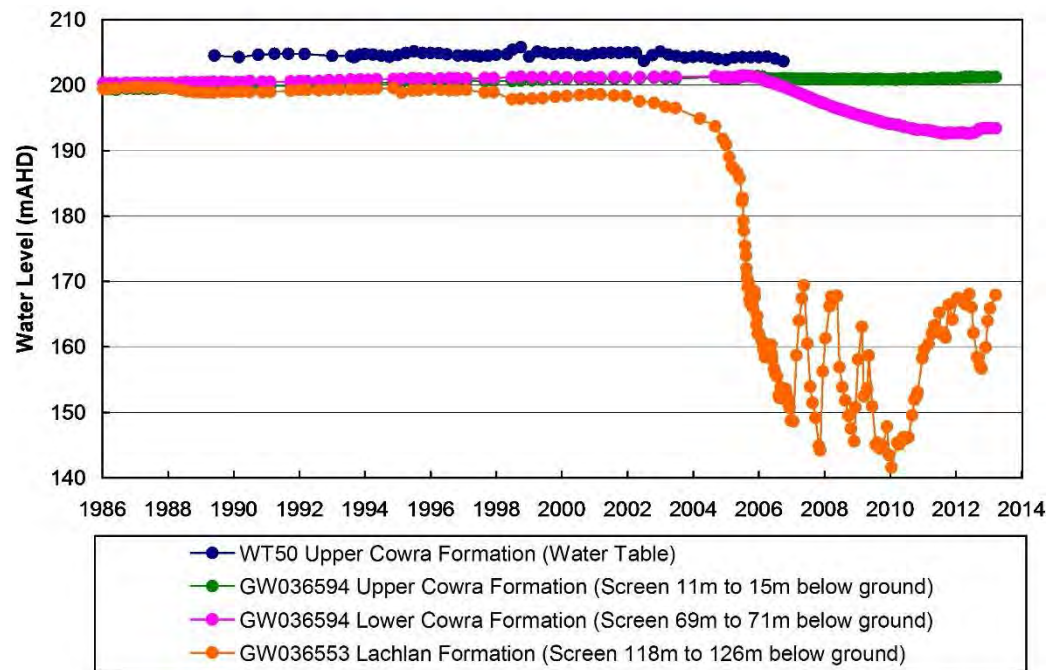

Figure 2.5. Hydrographs for approximately coincident piezometers in the BCPB area.

Figures 2.6 and 2.7 show water level observations for Evolution piezometers and GW036553 at the BCPB and ESB respectively, compared to total pumping, up to August 2016. The strong inverse correlation between piezometer water level and borefield pumping can be seen.

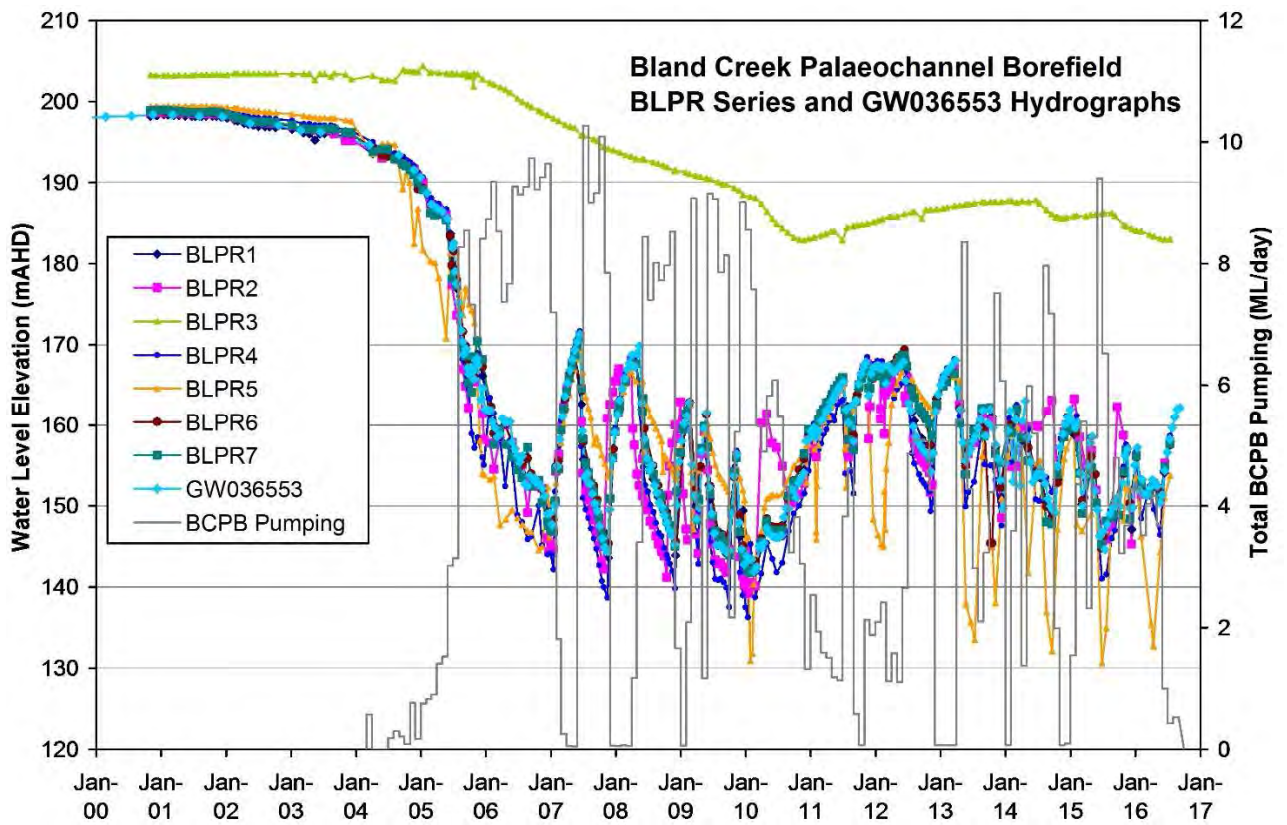

Figure 2.6. Monitoring piezometer hydrographs for the BCPB.

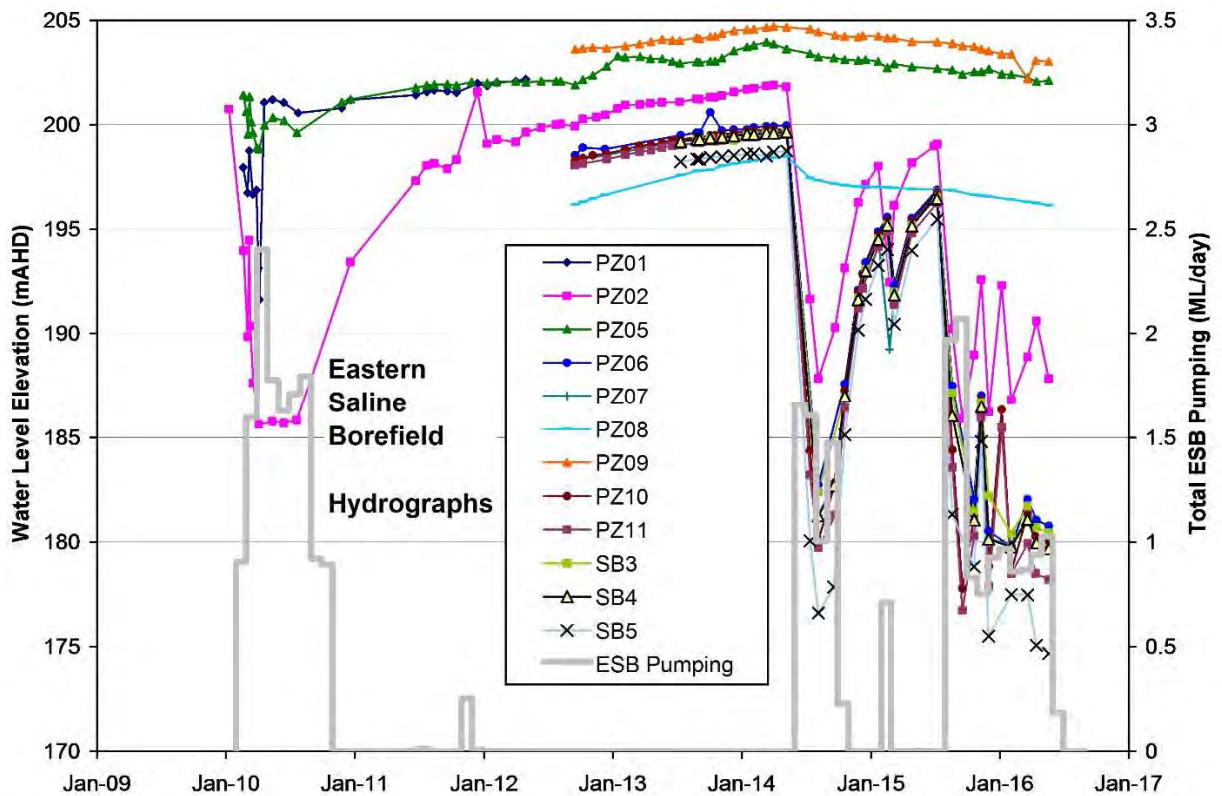

Figure 2.7. Monitoring piezometer hydrographs for the ESB.

2.6.3. Hydraulic Head Surfaces

Available monitoring data have been used to interpolate hydraulic head surfaces for the Upper Cowra, Lower Cowra, and Lachlan Formations for December 1997 (prior to the commencement of significant pumping from the Lachlan Formation) and September 2006 (two years after commencement of the CGO). These surfaces are shown in Appendix C. The main changes in hydraulic head surfaces between these times are:

- The disappearance of the groundwater mound in the Upper Cowra Formation underneath Lake Cowal. The water level in Lake Cowal was probably at around 205 mAHD in mid 1998 (see Figure 2.2).
- The appearance of the drawdown cone around the BCPB.

The 1997 surfaces indicate overall westward groundwater flow. Trends in the Lower Cowra and Lachlan Formations suggest north-south structural features on the western side of the palaeochannel may play a part in groundwater drainage. The 2006 surfaces show the effects of significant pumping from the Lachlan Formation at the BCPB and in the Billabong Area. The time at which pumping started in the Billabong area is not known.

Water levels in the Upper Cowra formation, where data are available, are an average of 5m below ground level. Vegetation in the area is characterised by food crops and scrub plains, with root depths probably not deeper than 2m below ground. Consumption of groundwater by evapotranspiration is therefore likely to be negligible, except at Lake Cowal, where water levels can rise to within the vicinity of the lake bottom during wet times.

Near the current mine pit, the Upper Cowra Formation shows some drawdown from drainage into the mine excavation, in conjunction with regional drawdown from drought conditions. This drawdown appears localised and is considered unlikely to significantly affect drawdown in the Upper Cowra, Lower Cowra, and Lachlan Formations further east (in the Bland Creek Palaeochannel).

2.6.4. Hydraulic Head Cross-Sections

Figures 2.8 and 2.9 show interpreted hydraulic heads along a north-south cross-section running approximately through the middle of the model domain, for December 1997 and January 2010 respectively. Salinity corrections have not been applied to the water level measurements however the corrections are not considered necessary given the moderate salinity magnitude of the Upper Cowra, and the inverted salinity profile for the sediments (that is, salinity decreases with depth, which acts to slightly amplify the downward hydraulic head gradient in the Upper Cowra).

In December 1997 pumping from the Lachlan Formation was significantly lower than in subsequent years, since drought conditions had not as yet developed. Hydraulic heads in the Lachlan Formation were similar to those in overlying strata, with gentle vertical gradients. The effect of drainage to the west is subtle but noticeable. Minor inflow from the Corinella Constriction appeared to be occurring. The BCPB and ESB were not active at this time.

The lowest hydraulic heads observed in the Lachlan Formation since monitoring began were observed in January 2010, when the BCPB and private bores were pumping at high levels from the Lachlan Formation. Several bore screens are more than 500m from the cross-section, but their positions have been projected onto the cross-section. However, hydraulic head contours are for the cross-section itself, therefore the shape of the contours do not closely align with the bore screens. Significant vertical gradients are apparent in the Lower Cowra, in response to significant depressurisation in the Lachlan Formation. Hydraulic head gradients in the underlying rock are interpreted to be large, with minor upward leakage.

Cowal Gold Operations Mine Life Modification
BCPB and ESB Groundwater Assessment

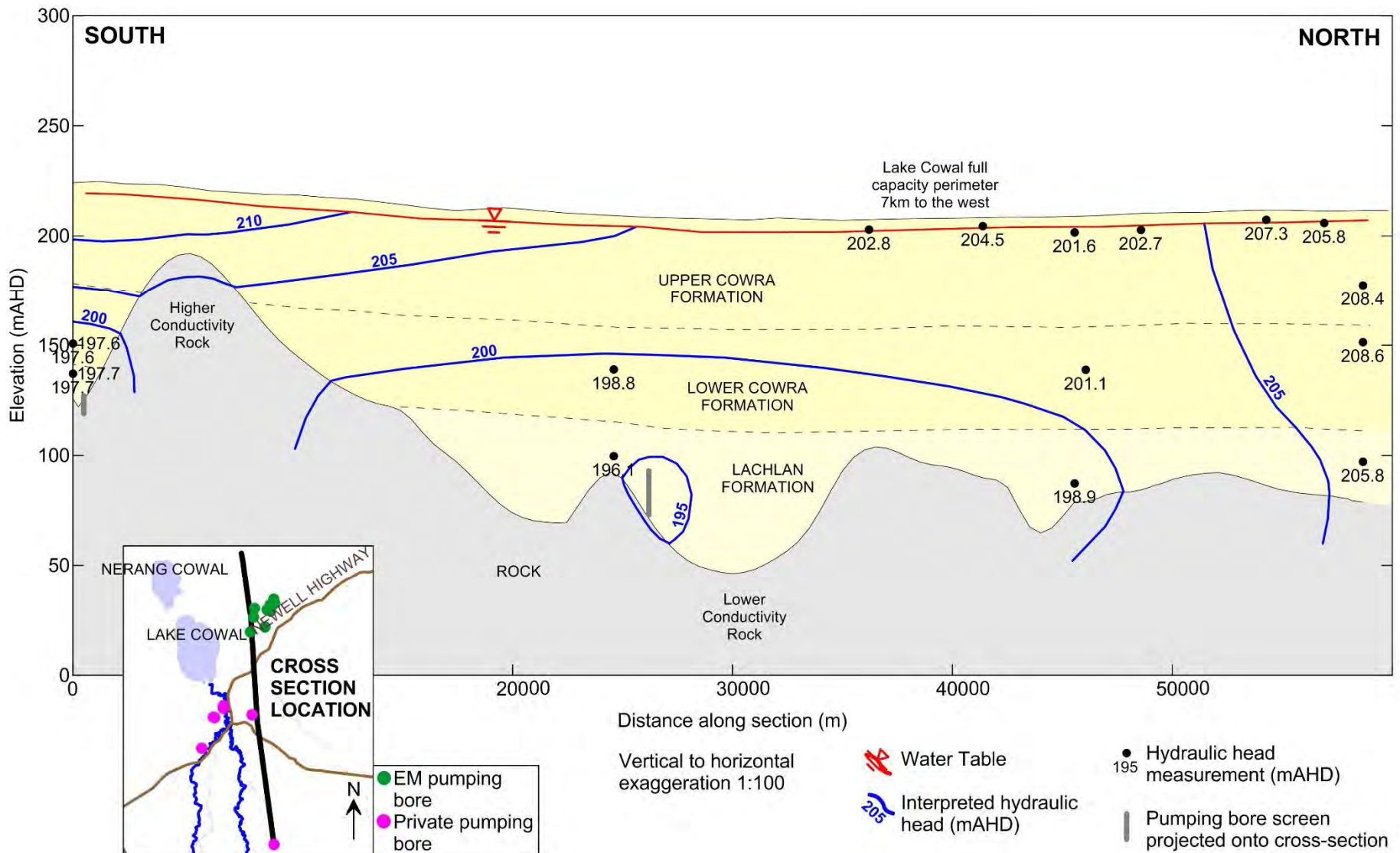

Figure 2.8. Interpreted hydraulic head cross-section for December 1997.

Cowal Gold Operations Mine Life Modification
BCPB and ESB Groundwater Assessment

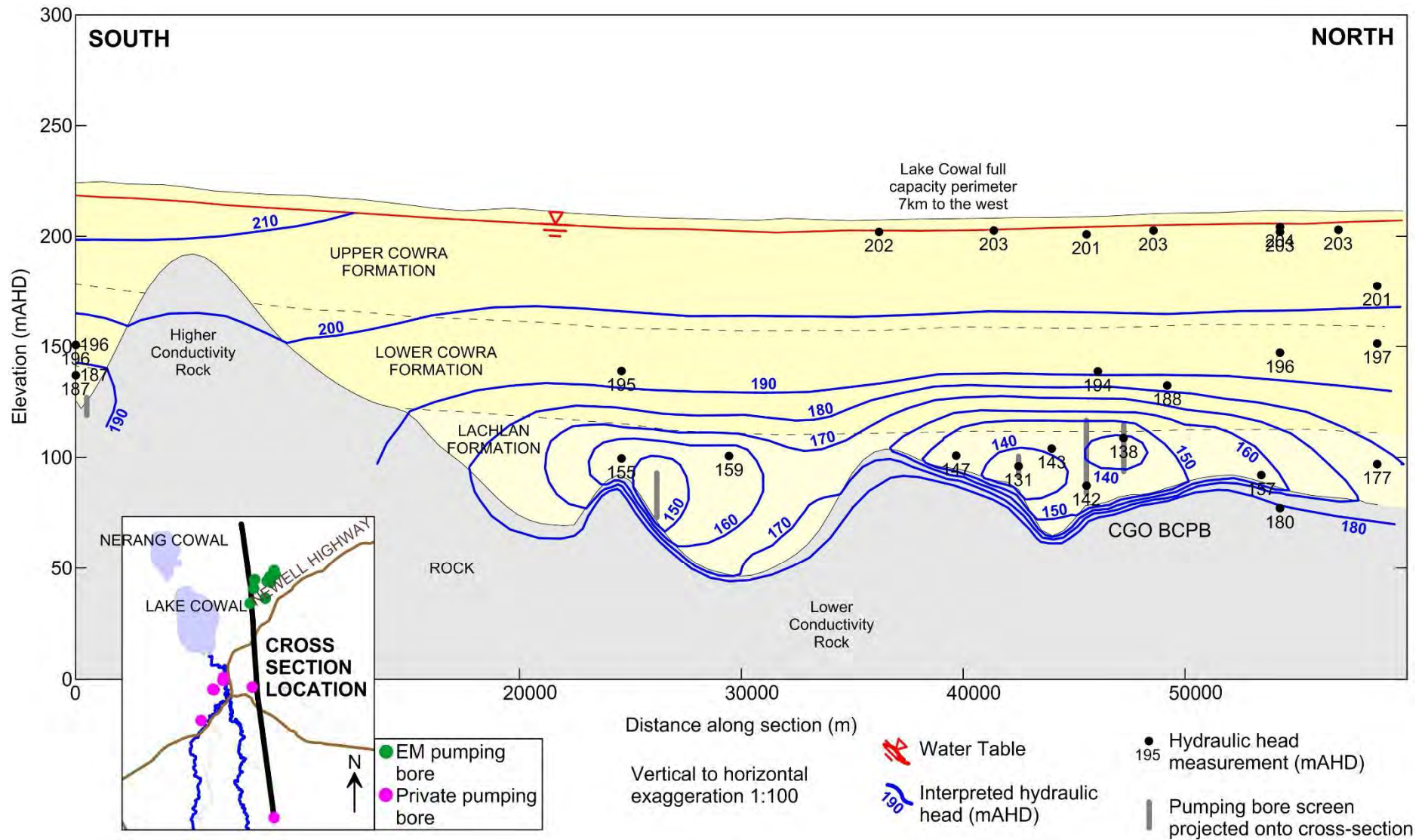

Figure 2.9. Interpreted hydraulic head cross-section for January 2010.

2.7. Groundwater Salinity

Additional monitoring of groundwater electrical conductivity (EC) at the BCPB and ESB, obtained since 2013, has been combined with previously existing data. Figure 2.10 shows EC averages for piezometers in the database, versus depth. The database used in Figure 2.10 is listed in Appendix D.

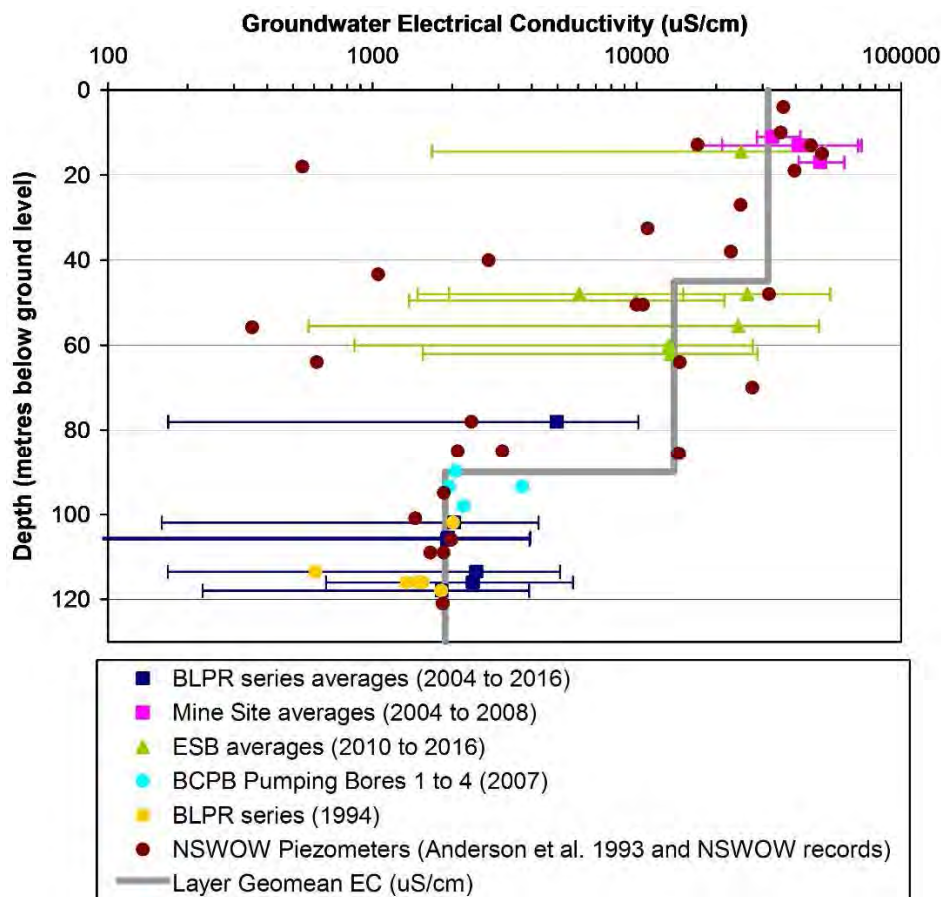

Figure 2.10. EC of groundwater in the regional area versus depth. Error bars indicate one standard deviation either side of the mean.

Figure 2.10 indicates a strong trend of decreasing salinity with depth. The Cowra Formation is conspicuous above 80m depth with greater salinities than the deeper Lachlan Formation. Near Lake Cowal, salinities in the Upper Cowra Formation are generally high (as are those in the Corinella and Lake Cowal cross-sections in Anderson et al. 1993). These data were used to calculate average representative EC for each formation in the BCPB area. Results are shown in Figure 2.10, using a layer subdivision as used in the numerical model, and are as follows (bracketed values are total dissolved solids (TDS) concentrations using a conversion factor of 0.67):

- Upper Cowra Formation: EC 31,300 $\mu\text{S/cm}$ (TDS 21,000 mg/L).
- Lower Cowra Formation: EC 13,800 $\mu\text{S/cm}$ (TDS 9,300 mg/L).
- Lachlan Formation: EC 1,900 $\mu\text{S/cm}$ (TDS 1,300 mg/L).

Figure 2.11 shows field EC measurements from Evolution piezometers at the BCPB and ESB, up to August 2016, with instrumental measurement errors removed.

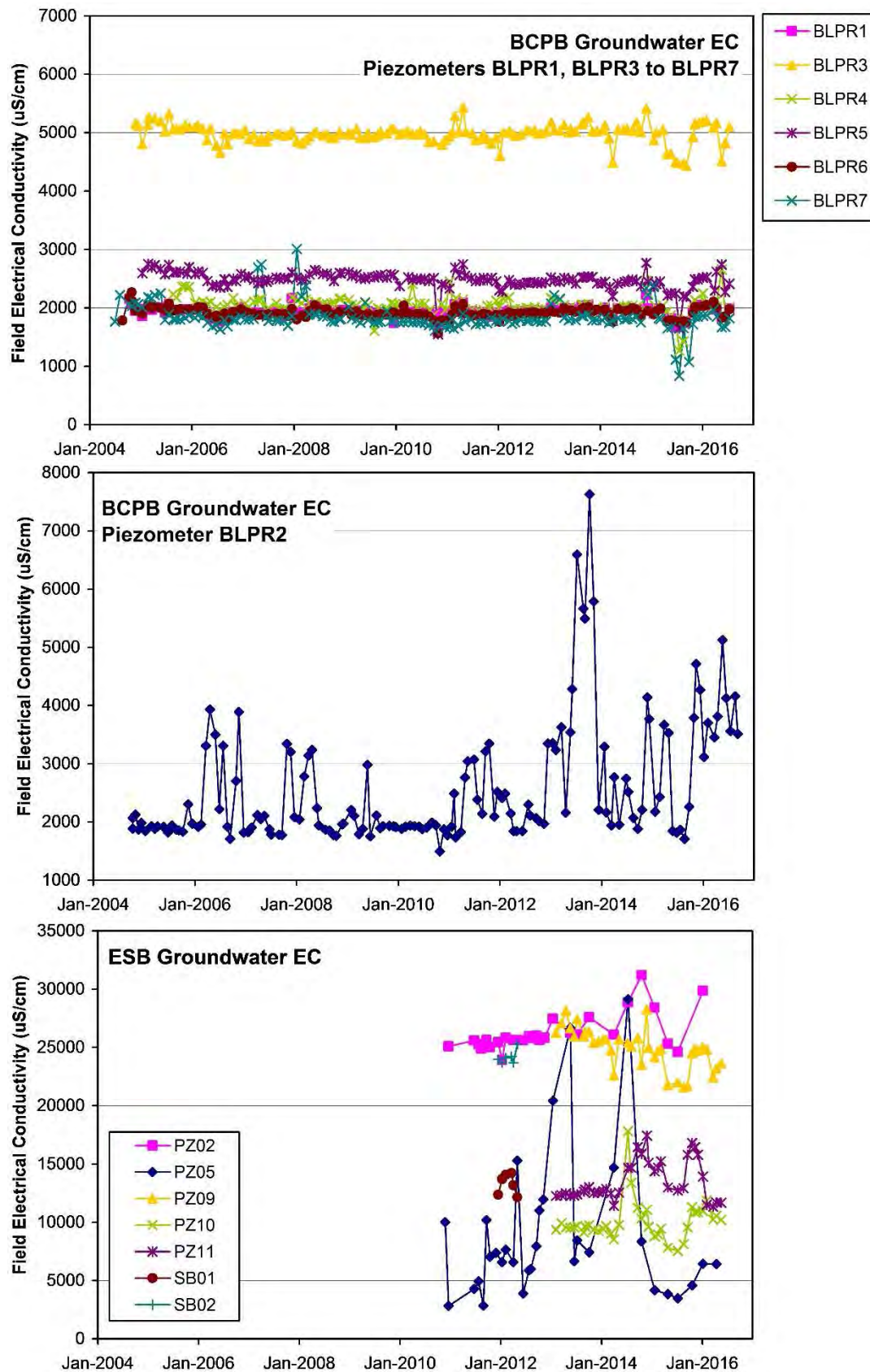

Figure 2.11. Groundwater EC versus time at Evolution monitoring piezometers.

The data show an average salinity of around 2000 $\mu\text{S}/\text{cm}$ for the Lachlan Formation, except for BLPR3 (about 5000 $\mu\text{S}/\text{cm}$, screened in the Lower Cowra Formation). BLPR2 shows fluctuating measurements for which the cause is uncertain, however EC fell substantially in late 2013; since late 2014, measurements indicate an overall upward EC trend (see Figure 2.11). Groundwater EC at the ESB is variable within the profile, adhering to the trend of decreasing EC with depth (see Figure 2.10).

2.7.1. Trend Analysis

Trends in Lachlan Formation EC at the BCPB were investigated by comparing an average EC dataset to BCPB pumping and the cumulative annual rainfall residual. The average EC dataset was compiled using observations from BLPR1, 4, 5, 6, and 7. First, observations at these piezometers were average over the length of record. Second, observations at BLP4 to 7 were offset by an amount equal to the difference between a piezometers average and the average at BLPR1. This produced a dataset with observations referenced to the BLPR1 mean. The process is reasonable given the similarity in absolute value and first derivative between the piezometers.

Figure 2.12a shows the average EC time series compared to BCPB pumping and the cumulative annual rainfall residual. A weak relationship with the rainfall residual may be present, however given the characteristics of the groundwater system and the extraction horizon, a relationship being recognisable over a 10-year period would be considered unlikely.

A more perceptible, but inverse, relationship with pumping appears to be present. Figure 2.12b shows the correlation between the derivative in EC and the derivative in BCPB pumping, and identifies a non-negligible inverse relationship. Since vertical flow velocities (from the Lower Cowra Formation into the Lachlan Formation) are likely to be significantly smaller than lateral flow velocities within the Lachlan Formation, the variation in pumping rate is thought to act by laterally attracting transient pulses of more distant lower EC Lachlan Formation groundwater (where downward vertical head gradients are smaller) into the immediate BCPB area, during pumping rate build-up, and thereby removing (or washing away) the slower build-up of higher EC groundwater seeping down from the Lower Cowra Formation. This supports the probable dominance of advective processes in solute transport in the system (see Section 5.3.4 below). This process would imprint as a higher frequency variation in EC on a broader long-term build-up of EC through vertical drainage, but would not halt the longer-term vertical drainage of overlying groundwater of higher EC. The latter process will act over a broader time scale and will operate while-ever downward vertical head gradients are present. Even should pumping stop completely, vertical drainage will continue afterwards, while these (dissipating) vertical gradients exist.

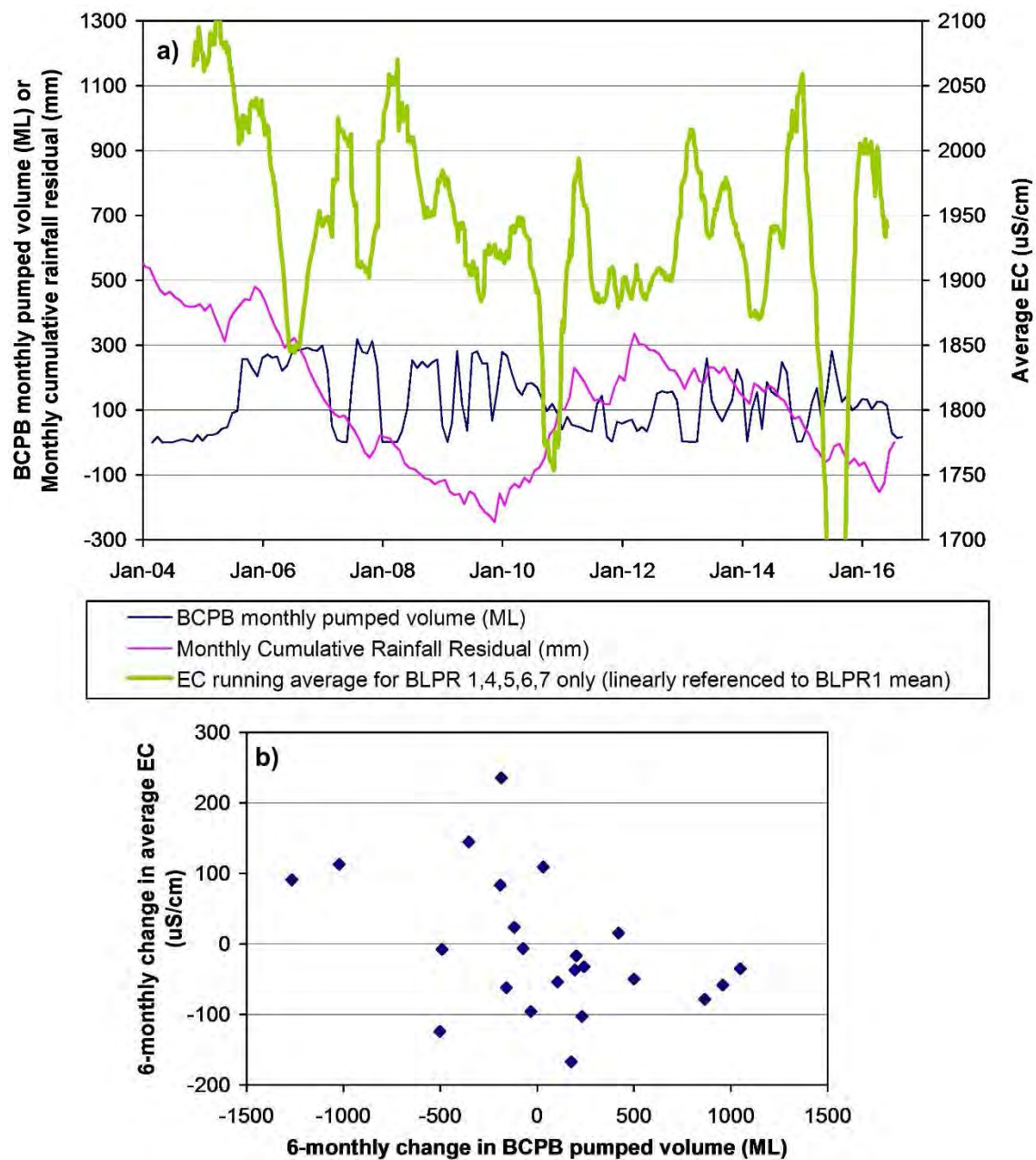

Figure 2.12. a) Comparison of average EC in the Lachlan Formation at the BCPB, and other trends; b) Correlation of EC and BCPB monthly derivatives.

2.8. Groundwater Extraction

Groundwater extraction in the area covered by the model domain occurs from Evolution and private bores. Appendix E lists the pumping bores in the area, and contains a map showing their locations. The list excludes basic rights bores (registered for stock and domestic use) which have no associated entitlement. Basic rights bores are not active in the model. The following discussion excludes basic rights bores.

Table 1 in Appendix E lists the 18 active pumping bores in the model. The model simulates the groundwater system from 1998. Three bores (Billabong 1, 2, and 3) were decommissioned after 1998 and before 2016, and are not active during predictive simulations.

Large groundwater extraction rates are concentrated in three main areas. One of the areas encompasses the CGO BCPB and ESB. The other two areas encompass private bores. These areas are identified on the map in Appendix E. Each area also has a monitoring piezometer used by the NSW government to monitor groundwater levels in the Lachlan Formation (at the request of the Bland Palaeochannel Groundwater Users Group) for groundwater management purposes. These piezometers have associated triggers defined by bore water levels where, should the bore water level fall to the trigger, various management actions are initiated. Table 2 lists the main pumping areas and associated pumping bores (see Appendix E for bore details) and trigger piezometers. The pumping bores listed in Table 2 account for about 96% of the known groundwater extraction from the Lachlan and Cowra Formations in the model area. All bores in Table 2 pump from the Lachlan Formation except the ESB which pumps from the Cowra Formation.

Table 2. High-extraction pumping areas in the regional area.

| Area | Pumping Bores | NSWOW Trigger Piezometer | |
|--------------|--|--------------------------|----------------------|
| | | Registration No. | Trigger Level (mAHD) |
| BCPB and ESB | BCPB: Evolution Bores 1 to 4. ESB: Evolution bores SB01 and SB02* | GW036553 | 134.0 |
| Billabong | Billabong 4 and Billabong 6 | GW036597 | 145.8 |
| Maslin | Maslin Bore | GW036611 | 143.7 |

* ESB pumping bores SB03 to SB05 (see Appendix E) are currently not used for pumping.

2.9. BCPB and ESB usage

Total usage for each of the BCPB and ESB, from commencement of the CGO (1 July 2004) to 31 August 2016, is shown graphically in Figures 2.6 and 2.7. Table 3 lists salient aspects of the usage.

The regulatory constraints for BCPB pumping (from the four bores in total), under the licence conditions, are understood to be as follows:

- Daily maximum of 15 ML
- Yearly maximum of 3,650 ML

Table 3. BCPB and ESB groundwater extraction from commencement of borefield operation to 31 August 2016.

| Borefield | Bore | Total Extracted Volume to 31 August 2016* (ML) | | Proportion pumped by each bore | Equivalent Average Extraction Rate (ML/day) |
|-----------|-----------------|--|--------------|--------------------------------|---|
| | | Borefield Total | Bore-by-Bore | | |
| BCPB | Bore1(GW701660) | 19040 | 6615 | 0.35 | 4.17 |
| | Bore2(GW701659) | | 4495 | 0.24 | |
| | Bore3(GW701658) | | 5737 | 0.30 | |
| | Bore4(GW701657) | | 2193 | 0.12 | |
| ESB | SB01 | 972 | 556 | 0.57 | 0.40 |
| | SB02 | | 417 | 0.43 | |

* Excludes the volumes pumped during pump testing of the four bores in early 2004 under a testing licence.
Note: BCPB and ESB commenced operation in July 2004 and February 2010 respectively.

The water supply for the CGO includes a number of surface water and groundwater supplies. Surface water supplies, which are dependent on rainfall, comprise runoff from a series of mine site dams and associated catchments, and use of water supplied in irrigation channels when available. The volume of these supplies has a dependency on rainfall, and so impacts the required usage from the BCPB and ESB. To estimate the most probable future usage for the BCPB and ESB, a correlation was undertaken of usage to date, and rainfall conditions. The CGO has been in operation for nearly 13 years, covering a wide range of rainfall conditions, and correlation results are considered useful for predictive estimates.

Correlation of annual rainfall against the following parameters was undertaken:

- Annual BCPB and ESB usage as a proportion of processing plant water demand.
- Annual BCPB and ESB absolute usage.

Correlations were undertaken for the period 2005 to 2015 inclusive, for which the average annual rainfall at Wyalong Post Office (Station 73054) was 456 mm. In calculating process water demand, the planning estimates of 1.7 kL/t for oxide ore and 0.9 kL/t for primary ore, have been used, rather than actual process water used, since the planning estimates have been used by Evolution for future water demand estimation (see the predictive simulation section).

Correlation results are shown in Figure 2.13. Correlations for usage as a proportion of process water demand and as absolute amounts are reasonable, however the latter are slightly better. BCPB usage is inversely proportional to rainfall, however ESB usage is directly proportional to rainfall. Table 4 lists calculations made from the correlations.

Table 4. Diagnostic parameters for correlation of BCPB and ESB usage with rainfall.

| Correlated usage variable | Overall averages | | Adopted values for predictive simulation | |
|---|------------------|-------|--|-------|
| | BCPB | ESB | BCPB | ESB |
| Usage as a proportion of process water demand | 0.247 | 0.021 | 0.225 | 0.036 |
| Absolute usage (ML/year) | 1667 | 75 | Not used | |

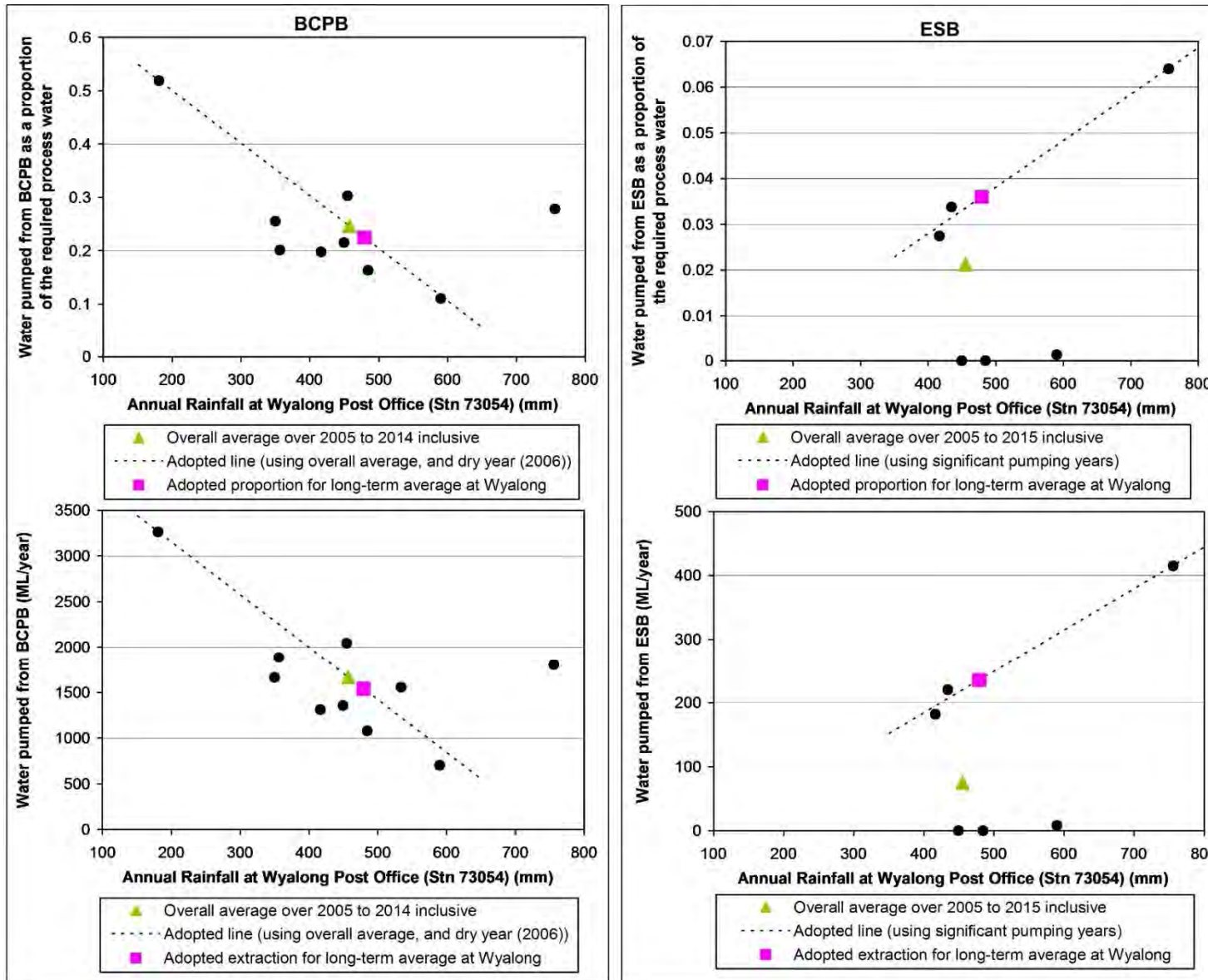

Figure 2.13. Correlation of measured BCPB and ESB usage versus rainfall.

Predictive simulation of the most probable future usage (see below) was undertaken using estimates for BCPB and ESB usage as a proportion of process water demand, as this allows the following variables in the future ore processing schedule supplied by Evolution to be incorporated in the BCPB and ESB pumping schedules:

- Annual oxide and primary processed ore tonnages.
- Annual variations in processed ore tonnages.

The adopted values relate to the long-term average annual rainfall for the area, and are related to the actual rainfall over the correlation period using the fitted lines shown in Figure 2.13. For the ESB, the years of low or nil usage are ignored, as this lends a slight conservatism to its estimate.

2.9.1. Comparison of actual and planned process water demand

To further assess the conservatism inherent in adopted future BCPB and ESB pumping schedules, it is useful to review actual process water demand and planned process water demand (using the planning rates discussed above) for the period since commencement of the CGO to the present, where data are available. The process water demand is dependent on ore processing rates, upon which the adopted future BCPB and ESB pumping schedules depend.

Table 5 lists actual and planned process water demand according to available information.

Table 5. Actual and planned process water demand.

| Year | Annual Ore Processing tonnage (Mt) | | Predicted Process Water Demand* (ML) | | | Measured Processing Plant Usage^ (ML) | Actual demand as a proportion of predicted demand |
|------|------------------------------------|---------|--------------------------------------|---------|-------|---------------------------------------|---|
| | Oxide | Primary | Oxide | Primary | Total | | |
| 2005 | 0.00 | 0.00 | 0 | 0 | 0 | | |
| 2006 | 3.70 | 0.00 | 6290 | 0 | 6290 | | |
| 2007 | 4.30 | 2.30 | 7310 | 2070 | 9380 | | |
| 2008 | 0.00 | 7.25 | 0 | 6521 | 6521 | 6749 | 1.03 |
| 2009 | 0.00 | 7.49 | 0 | 6742 | 6742 | 5970 | 0.89 |
| 2010 | 0.00 | 7.20 | 0 | 6483 | 6483 | 5744 | 0.89 |
| 2011 | 0.00 | 7.04 | 0 | 6340 | 6340 | | |
| 2012 | 0.00 | 7.34 | 0 | 6606 | 6606 | | |
| 2013 | 0.00 | 6.99 | 0 | 6295 | 6295 | 5486 | 0.87 |
| 2014 | 0.00 | 7.37 | 0 | 6630 | 6630 | 5786 | 0.87 |

* Calculated using 1.7 kL/t for oxide ore and 0.9 kL/t for primary ore. ^ From supplied data in "Site Water Tracker" excel files.

Results in Table 5 indicate that in recent years the process water demand has been around 90% or less of the planned demand.

3. Hydrogeological conceptual model

Monitoring data collected at the CGO since 2013, supplied to Coffey, supports the conceptual model used in Coffey (2013). There are no observations that suggest any alteration to the conceptual model. The conceptual model from 2013 is adopted in the current study and summarised below.

The climate in the model area is characterised by low rainfall and high evaporation. For average conditions, a rainfall deficit occurs over most months of the year. Surface drainage is intermittent.

Recharge to the groundwater system occurs by the following processes:

- Rainfall infiltration.
- Leakage from Bland Creek when flowing.
- Intermittent flooding.
- Deep drainage from irrigation practices (mostly in the northern areas).
- Groundwater inflow through the Corinella Constriction.

There will also be a minor component of recharge to the fringes of the alluvial sequence from shallow bedrock which will have higher conductivity due to lower overburden pressures.

The subsurface medium comprises unconsolidated sediments. Finer-grained, lower K sediments overlie a thin but significant sequence of coarser-grained, higher K sediments. Media properties, combined with the prevailing climate, creates a system of high groundwater salinity near the surface and lower salinity at depth. Observations collected at the ESB since 2012 have allowed a more detailed definition of the variation of EC with depth.

Discharge from the groundwater system occurs by the following processes:

- Extraction from water supply bores for stock/domestic, irrigation, and industrial uses.
- Intermittent evaporation from surface ponds (local groundwater flow systems only).
- Groundwater outflow through the Corinella Constriction.

4. Numerical model verification

Appendix F provides a summary of the numerical model structure, boundary conditions, and calibrated media properties. Refer to Coffey 2013 for a detailed description of the numerical model and the recalibration undertaken in 2010.

In the current work, model verification of measured water levels was undertaken for the following piezometers:

- Evolution BLPR piezometer series (monitoring of the BCPB).
- Evolution PZ series, and SB03 to SB05 (monitoring of the ESB). Screens for these piezometers either straddle the model boundary between Layers 1 and 2 (the Upper and Lower Cowra Formations respectively), or are in close proximity to it. Verification is undertaken by extracting modelled water levels in both Layers 1 and 2 and comparing to observations.
- NSWOW trigger piezometer GW036553. Verification for NSWOW trigger piezometers GW036597 and GW036611 was not possible as accurate usage for the Maslin and Billabong bores is required to reproduce observations. The latter piezometers are, however, assessed in predictive simulations.

Apart from the bores in the BCPB, the bores with the three largest groundwater extraction rates in the model area are Billabong 4, Billabong 6, and Maslin. This extraction significantly affects water levels in NSWOW trigger piezometers GW036597 and GW036611. Available usage data for these private pumping bores covers a period up to 1 July 2010 only, therefore no model verification of measured water levels was undertaken for piezometers GW036597 and GW036611.

4.1. Results

Verification hydrographs are shown in Appendix G. Hydrographs for the BCPB area show reasonable agreement. Taking into account the straddling of model Layers 1 and 2 by ESB monitoring piezometers, the averages of modelled water levels in Layers 1 and 2 are considered to show reasonable agreement with observations, overall. There is a degree of uncertainty in reported screen intervals for ESB monitoring piezometers (see Section 2.6.1).

The match between simulated and observed water levels indicates the model is acceptably verified, and suitable for use in a predictive capacity.

5. Predictive Simulation

5.1. Simulated Scenarios

Three predictive scenarios were modelled as follows:

- Scenario A (Maximum BCPB Pumping). The BCPB pumps at the maximum possible rate, beginning 1 September 2016, such that the water level in NSWOW trigger piezometer does not fall below the trigger level of 134 mAHD. ESB pumping is fixed at 1.5 ML/day (requested by Evolution in the same scenario undertaken in 2013, and adopted here). This scenario required iterative runs to find the maximum rate. BCPB and ESB pumping terminates on 31 December 2032.
- Scenario B (Most Probable BCPB and ESB Pumping). The BCPB and ESB pump at variable rates, beginning 1 September 2016, according to the supplied future ore processing schedule, and the adopted proportions of BCPB and ESB pumping with respect to future process water demand. The annual pumping schedules defined in this way are listed in Table 6. BCPB and ESB pumping terminates on 31 December 2032.
- A null case, where CGO pumping never occurs.

Table 6. BCPB and ESB future annual pumping schedules for Scenario B (most probable pumping).

| Calendar Year | Mining Year | Planned Ore Processing Tonnage (Mt) | | | Required Process Water (ML) | | | Annual average usage [^] (ML/day) | |
|-----------------------|-------------|-------------------------------------|---------|-------|-----------------------------|---------|-------|--|------|
| | | Oxide | Primary | Total | Oxide | Primary | Total | BCPB | ESB |
| 2016* | 12 | 0.00 | 7.17 | 7.17 | 0 | 6453 | 6453 | 3.96 | 0.64 |
| 2017 | 13 | 0.00 | 7.50 | 7.50 | 0 | 6750 | 6750 | 4.16 | 0.67 |
| 2018 | 14 | 0.00 | 7.36 | 7.36 | 0 | 6624 | 6624 | 4.08 | 0.65 |
| 2019 | 15 | 0.00 | 7.30 | 7.30 | 0 | 6570 | 6570 | 4.05 | 0.65 |
| 2020 | 16 | 3.82 | 3.68 | 7.50 | 6494 | 3312 | 9806 | 6.02 | 0.96 |
| 2021 | 17 | 0.00 | 7.46 | 7.46 | 0 | 6714 | 6714 | 4.14 | 0.66 |
| 2022 | 18 | 0.00 | 7.36 | 7.36 | 0 | 6624 | 6624 | 4.08 | 0.65 |
| 2023 | 19 | 0.00 | 7.33 | 7.33 | 0 | 6597 | 6597 | 4.06 | 0.65 |
| 2024 | 20 | 0.00 | 7.47 | 7.47 | 0 | 6723 | 6723 | 4.13 | 0.66 |
| 2025 | 21 | 0.00 | 7.50 | 7.50 | 0 | 6750 | 6750 | 4.16 | 0.67 |
| 2026 | 22 | 0.00 | 7.50 | 7.50 | 0 | 6750 | 6750 | 4.16 | 0.67 |
| 2027 | 23 | 0.00 | 7.50 | 7.50 | 0 | 6750 | 6750 | 4.16 | 0.67 |
| 2028 | 24 | 0.00 | 7.50 | 7.50 | 0 | 6750 | 6750 | 4.15 | 0.66 |
| 2029 | 25 | 0.00 | 7.50 | 7.50 | 0 | 6750 | 6750 | 4.16 | 0.67 |
| 2030 | 26 | 2.33 | 5.17 | 7.50 | 3961 | 4653 | 8614 | 5.31 | 0.85 |
| 2031 | 27 | 7.50 | 0.00 | 7.50 | 12750 | 0 | 12750 | 7.85 | 1.26 |
| 2032 | 28 | 2.29 | 0.00 | 2.29 | 3893 | 0 | 3893 | 2.39 | 0.38 |
| Overall average rate: | | | | | | | | 4.43 | 0.71 |

* Commences 1 Sep 2016 in model, for four months. ^ Calculated using proportions of 0.225 and 0.036 for the BCPB and ESB respectively.

For Scenarios A and B, the total pumping rates in Table 5 are distributed amongst the 4 bores of the BCPB and the 2 bores of the ESB according to the proportions pumped by each bore up to 31 August

2016 (Table 3). Pumping at the ESB is subject to the drawdown constraint where the groundwater level in PZ02 (the ESB monitoring piezometer historically showing the largest drawdown) is not to fall below the base of the bore screens. Based on supplied information, the elevations of the base of the bore screens are 144.7 mAHD for SB01 and 144.6 mAHD for SB02.

All simulations cover a future period of about 26 years commencing on 1 September 2016 and ending on 31 December 2042. This allows for 10 years of recovery following termination of pumping at the BCPB and ESB (for Scenarios A and B). For all scenarios, the following future conditions are applied:

- Average rainfall occurs from 1 September 2016 as an invariant annual rate equivalent to 1% of 479 mm/year (the average rainfall at Wyalong Post Office between 1896 and 2016).
- Water levels for Lake Cowal, and Bland and Barmedman Creeks, have been assigned by calculating their average water levels over the period of record and applying these averages over the entire simulation period. These averages are 0.35m for Bland and Barmedman Creeks and 0.5m for Lake Cowal.
- Private pumping as defined in the following section.

5.2. Private bore pumping

Nine private bores are active during the predictive simulations, as listed in Table 6. These bores all pump from the Lachlan Formation. Actual past usage information is available for four of the bores up to June 2010. For the remaining five bores, no usage information has ever been received. In 2007 the Lachlan Valley Water Group (LVWG) supplied future usage estimates for all 9 bores. The LVWG estimates were used in the current work for predictive simulations (applied from 1 September 2016).

Table 7. Private Bore future average annual pumping rates for both predictive scenarios.

| Bore | Period of available usage data | Calculated historical average annual usage (ML/day) | Estimated future average annual usage as at 2007 (Lachlan Valley Water Group)^ (ML/day) |
|----------------|--------------------------------|---|---|
| Billabong 3/6* | 31-Dec-97 to 30-Jun-10 | 1.90 | 2.22 |
| Billabong 4 | 30-Sep-05 to 30-Jun-10 | 1.94 | 2.40 |
| Maslin | 31-Jul-04 to 30-Jun-10 | 3.01 | 4.52 |
| QuandiallaTWS | 30-Jun-03 to 30-Jun-10 | 0.10 | 0.10 |
| Hart | | N/A | 0.02 |
| MooraMoora | | N/A | 0.13 |
| Muffet | | N/A | 0.02 |
| Trigalana | | N/A | 0.08 |
| Trigalana East | | N/A | 0.13 |
| Total: | | | 9.62 |

* Billabong 3 was replaced by Billabong 6 in 2008 (see Appendix E).

^ Used for predictive simulations (applied from 1 September 2016).

For the bores where usage data are available, a historical annual average pumping rate (manifested as higher rates in discrete seasons) was calculated for comparison to the LVWG estimates; the historical averages are listed in Table 7. The usage data cover a period of significant drought. LVWG estimates compare well with historical averages. Except for the Quandialla Town Water Supply bore,

the LVWG estimates are an average of 30% higher than calculated historical averages, providing a threshold to account for worse climatic conditions than those seen up to 2007, or other unforeseen circumstances such as growth in agricultural output for the businesses concerned. The Quandialla Town Water Supply estimate is the same as the historical average, and indicates little reliance on changes in climatic conditions, but does not account for population growth in the town, should it occur.

5.2.1. Inactive pumping bores

Table 2 in Appendix E lists an additional 10 licensed private pumping bores in the model area that have the potential to pump large amounts, but for which no usage data have ever been received, and no usage estimates have ever been supplied. Their status is unknown, and as a result, they are designated inactive in the model. It is not known if any of these may be pumping groundwater, however their inactivity has allowed reasonable replication of water level observations up to the present. Their future usage was unable to be estimated and they are inactive in predictive simulations.

The Warrakimbo bore, located very close by the Maslin Bore, is licensed for irrigation and has a large allocation. As at 2010, it was understood that the bore installed by Mr Mattiske in 2007 (not active in the model) approximately midway between Bores 1 and 2 of the BCPB, did not operate.

Billabong 5 was completed on 23 December 2008 as a replacement for Billabong 1 and 2. The potential for this bore to have been used since 2008, or to be used in the future, is high.

5.3. Results

5.3.1. Water level hydrographs

NSWOW Piezometer GW036553

Figure 5.1 shows the predicted hydrographs for piezometer GW036553 for Scenarios A and B. For Scenario A, the maximum allowable total BCPB pumping rate to maintain piezometer water levels above the trigger level is 5.1 ML/day.

For Scenario B, the piezometer water level stays above the trigger level during the simulation, except in 2031 (mining year 27) when large tonnages of oxide ore are processed. The lowest modelled water level is 125.0 mAHD.

ESB Piezometer PZ02

Figure 5.2 shows the predicted hydrographs for piezometer PZ02 for Scenarios A and B. Modelled water levels in the Cowra Formation at the ESB remain comfortably above the base of the pumping screens during ESB operation.

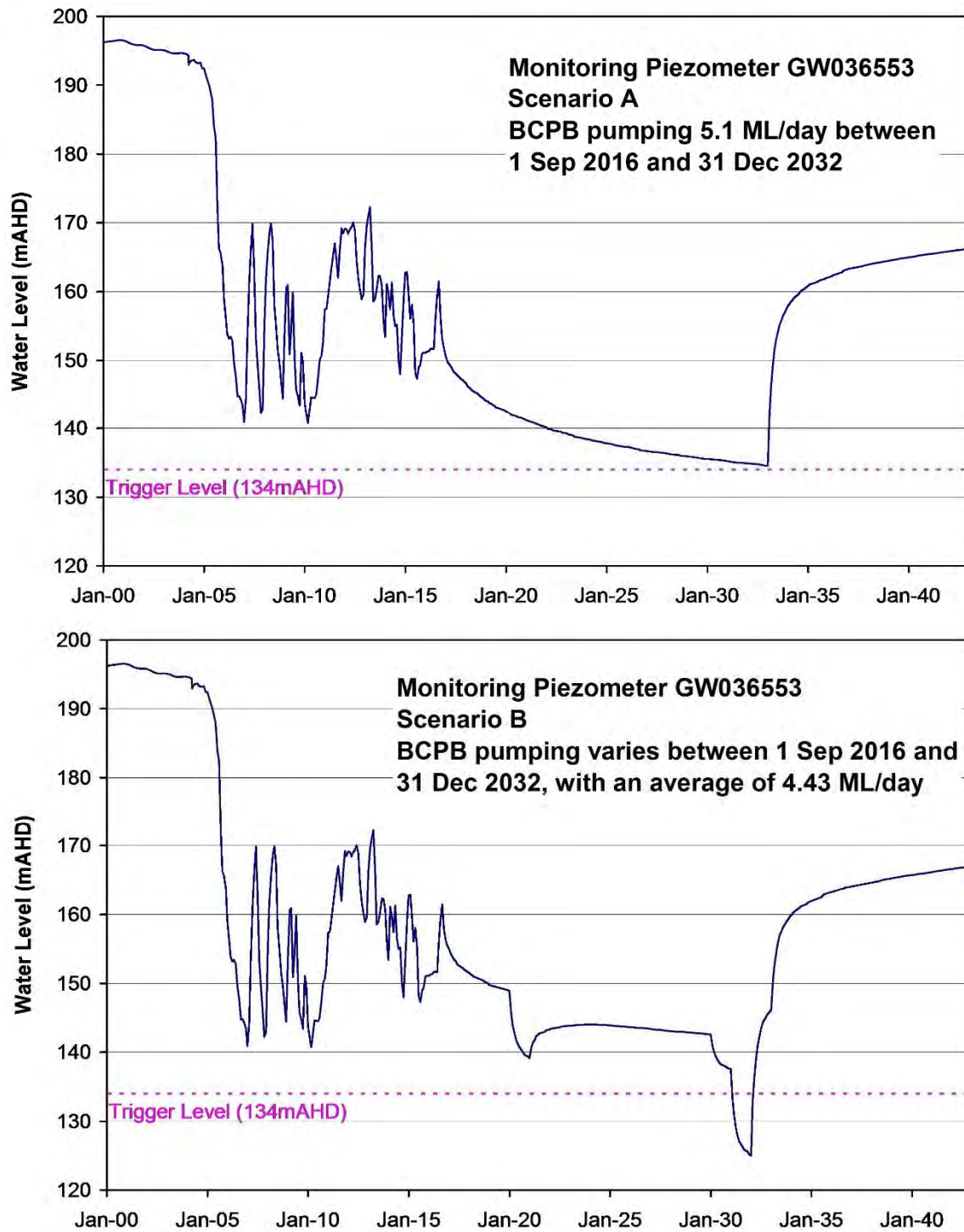

Figure 5.1. Predictive hydrographs for GW036553 for Scenarios A and B.

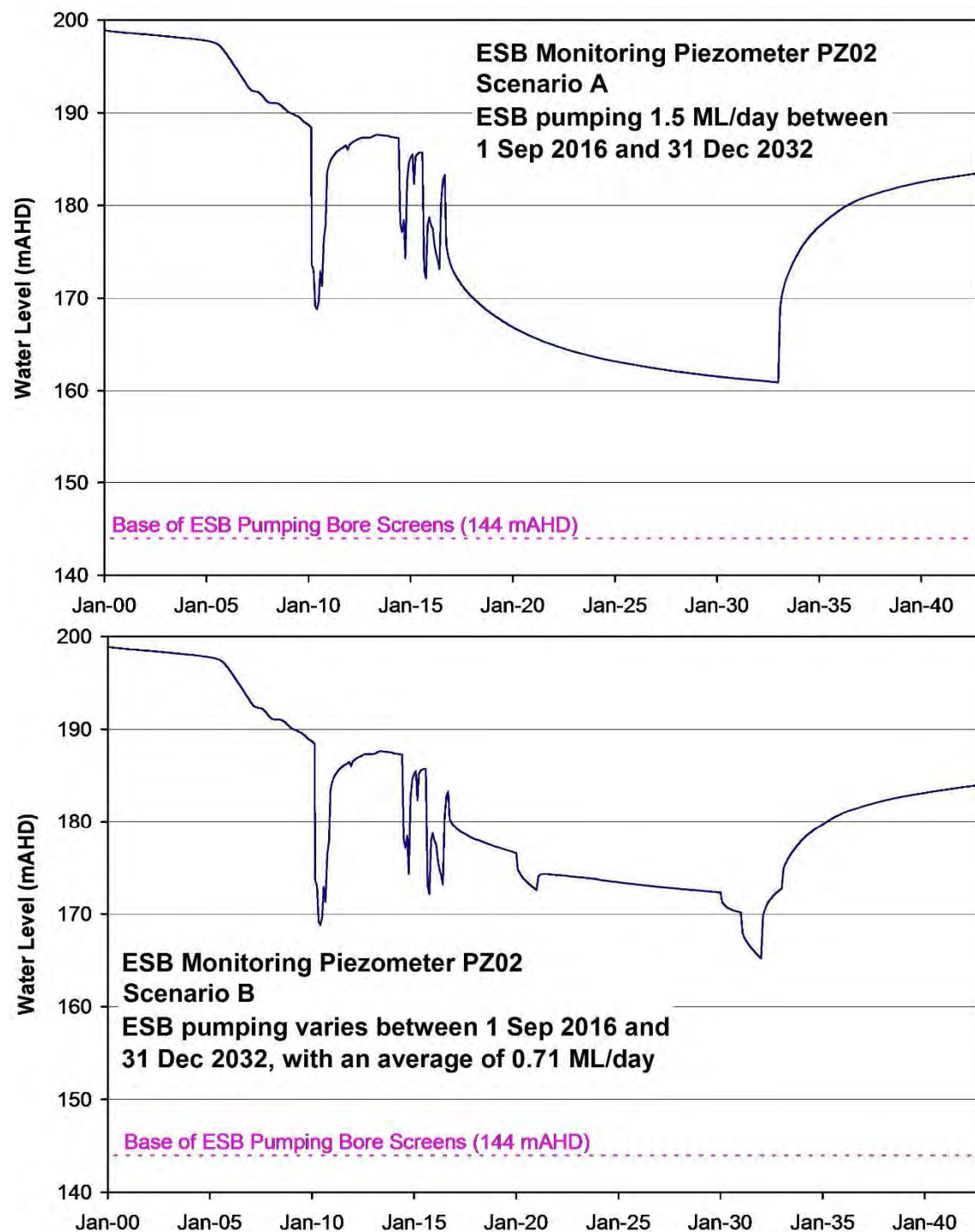

Figure 5.2. Predictive hydrographs for ESB PZ02 for Scenarios A and B.

NSWOW piezometers GW036597 and GW036611

Due to the unavailability of usage information for the Billabong and Maslin bores, the model was used to calculate the drawdown at GW036597 and GW036611 due only to the CGO (using results from the null case). This drawdown was then subtracted from predictive hydrographs for GW36597 and GW036611 which were compiled using historical measurements. These are referred to as predictive surrogate hydrographs, and their calculation is discussed below.

Figure 5.3 shows the observations available for the piezometers, and the cumulative monthly rainfall residual at ABM station 73054. Groundwater pumping from the Billabong and Maslin bores (the dominant influences on the hydrographs) is heavily dependent on rainfall. In fact, these bores are used for irrigation makeup water during shortfalls in surface water irrigation supplies.

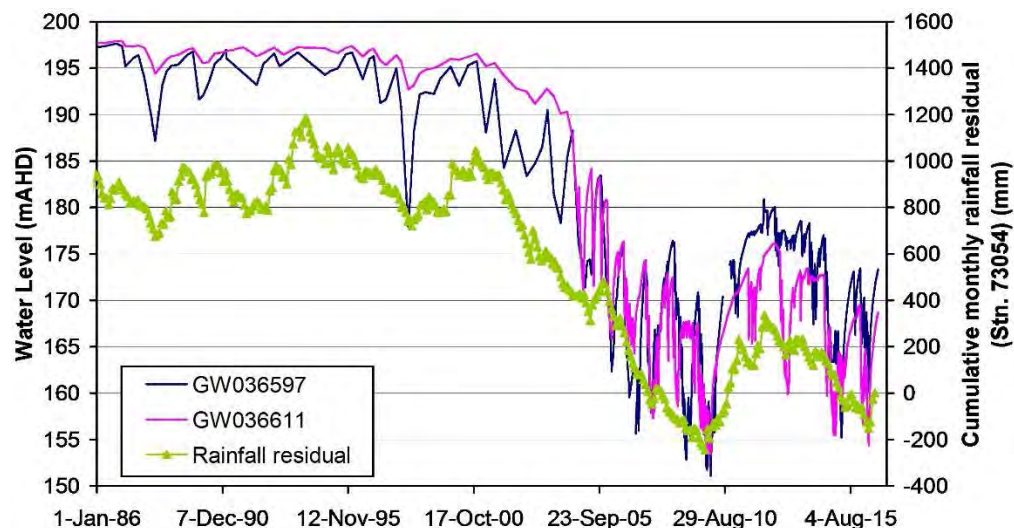

Figure 5.3. Available monitoring data for GW036597 and GW036611 compared to the cumulative monthly rainfall residual.

Predictive surrogate hydrographs were compiled by taking the three lowest water levels as measured during the three growing seasons of greatest pumping in each piezometer over the period of record, taking an average of these, and applying the average value as an invariant level to the hydrographs from 1 September 2016. Figure 5.4 shows the water levels used for calculation, and the calculated predictive surrogate hydrographs.

The calculation method takes into account the severe drought conditions experienced in the area between 2001 and 2009. Dry conditions began again in mid-2012, however these conditions may have entered a turning point in 2016. The conservatism imparted using the surrogate calculation method depends on weather patterns experienced in the future. Only slight conservatism is present should the 2001-2009 drought conditions reoccur in the last years of the CGO, when the drawdown incurred at the piezometers, by the BCPB and ESB, will be large.

Figure 5.4 shows surrogate hydrographs as calculated, and the additional modelled drawdown incurred by the BCPB and ESB, from 1 September 2016. Based on the extended assumptions as discussed above, modelling results suggest the water levels in the piezometers may remain above the trigger levels.

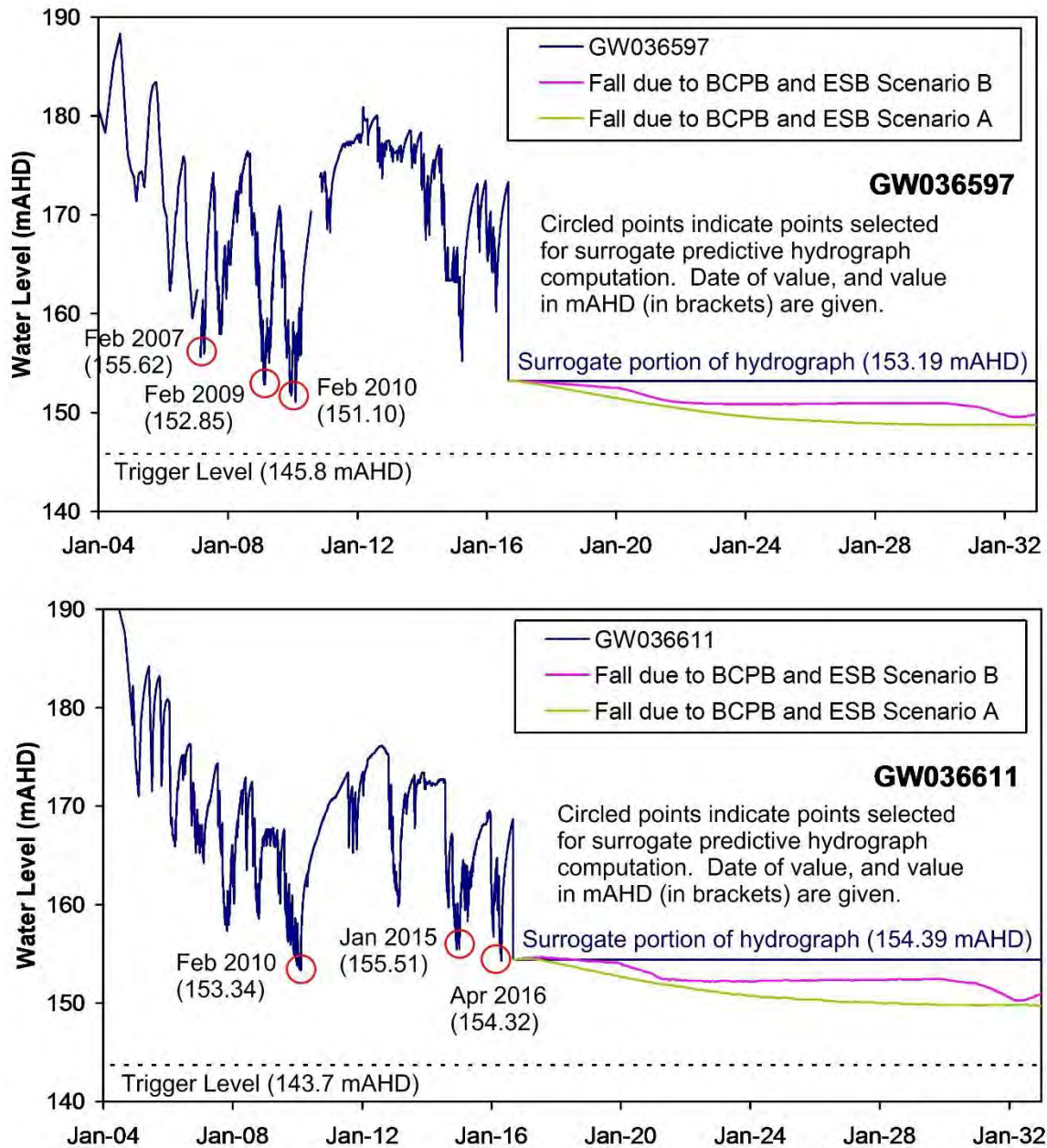

Figure 5.4. Modelled drawdown at GW036597 and GW036611 from BCPB and ESB operation.

5.3.2. Water level drawdown

Groundwater drawdown achieves a maximum just before the end of BCPB and ESB operation, on 31 December 2032. At this time, maximum modelled drawdowns in the Upper Cowra Formation are 2.2 m for Scenario A and 0.9 m for Scenario B, both occurring in the central part of the ESB. These drawdowns are not expected to create difficulty for the majority of private bores in the area.

Drawdown in the Lower Cowra and Lachlan Formations for 31 December 2032 are shown in Appendix H. Table 8 provides a summary of results.

Table 8. Drawdown in the Lower Cowra and Lachlan Formations for 31 December 2032 (cessation of BCPB and ESB pumping).

| Formation and Location | Scenario A | Scenario B |
|---|-------------|-------------|
| Maximum drawdown in Lower Cowra Formation | | |
| Drawdown (m) | 40.5 | 34.9 |
| Location | ESB | BCPB |
| Maximum drawdown in Lachlan Formation | | |
| Drawdown (m) | 70.2 | 68.8 |
| Location | Maslin Area | Maslin Area |
| Maximum drawdown in Lachlan Formation over the BCPB (m) | 69.8 | 56.1 |

There are private registered bores screened in the Lachlan Formation in the area of the BCPB however impacts on these bores are being monitored and mitigation measures have been developed to mitigate potential impacts (see below).

Based on a search of registered private water bore records in 2011, there are 34 private bores (excluding government piezometers and Evolution piezometers or pumping bores) within 15 km of the BCPB and ESB which appear to be screened in the Upper and/or Lower Cowra Formations (depths less than 90m). 32 of these bores are located outside the model domain (29 are located to the east and northeast, on the other side of rock ridges or interpreted shallow bedrock, and three are located to the north-northeast, past the northern model boundary and within the northernmost parts of the Corinella Constriction). The remaining two bores are GW029574 and GW702230. Their locations are shown on the map in Appendix E. Table 9 lists known completion details for these bores.

Table 9. Registered private bores screened in the Cowra formation within 15 km of the BCPB and ESB (excluding government and Evolution bores).

| Bore | Easting (mMGA) | Northing (mMGA) | Depth (mbgl) | Water Level (mbgl) | Licensed use |
|----------|----------------|-----------------|--------------|--------------------|--------------|
| GW029574 | 553360 | 6273194 | 88 | 30 | Stock |
| GW702230 | 555812 | 6287547 | 66 | | Irrigation |

GW702230 is located within the ESB and is known as the Duff bore. There is understood to be an agreement between the mine and the bore owner that permits temporary transfer of water from this bore for use in the mine water supply.

Government bore records indicate that GW029574 is privately owned, and was installed in 1969. A maximum modelled drawdown of between about 31 m and 33 m (in the Lower Cowra Formation) is calculated for GW029574, however the bore is 88m deep and may be able to continue operation if the screen length is sufficiently long and optimally located.

5.3.3. Flow budgets

Table 10 lists the modelled groundwater flow budget for 31 December 2032, immediately prior to cessation of pumping at the BCPB and ESB, for Scenarios A and B, and the null case (BCPB and ESB inactive for the entire simulation period). This time is the time of greatest groundwater drawdown.

Table 10. Flow budgets at the end of BCPB and ESB pumping (31 December 2032).

| Component | Scenario A | | Scenario B | | Null (BCPB and ESB Inactive) | |
|------------------------------------|-------------|--------------|-------------|--------------|------------------------------|--------------|
| | In (ML/day) | Out (ML/day) | In (ML/day) | Out (ML/day) | In (ML/day) | Out (ML/day) |
| Recharge | 17.74 | | 17.74 | | 17.74 | |
| Media storage | | 5.64 | | 8.32 | | 8.83 |
| River Leakage | | 1.01 | | 1.05 | | 1.22 |
| Flow across Corinella Constriction | 5.10 | | 4.03 | | 1.71 | |
| Pumping | | 16.22 | | 12.39 | | 9.62 |
| Total | 22.84 | 22.87 | 21.78 | 21.77 | 19.45 | 19.68 |
| Discrepancy | -0.03 | | 0.01 | | -0.22 | |

Note: Component values are rounded to two decimal places. Totals are calculated from unrounded component values, then rounded to 2 decimal places, therefore each total may differ slightly from the sum of corresponding rounded components.

Flow budgets indicate that groundwater pumping is being sourced almost entirely from media storage on 31 December 2032. Flow budget discrepancies are reasonable.

5.3.4. Salinity

When a fresh water source is pumped and draws vertical leakage from an overlying source of higher salinity, the resulting distribution of total dissolved solids (TDS) concentration in the pumped source is not uniform. The concentration distribution will first be significantly controlled by the variation in the vertical hydraulic head difference between the sources (which is a maximum at the pumped bore). This distribution may change with time, during and after pumping, depending on the magnitude of lateral flow and other factors.

An assessment of the potential impact of extraction from lower EC water in the Lachlan Formation with vertical drainage from overlying higher EC media has been undertaken using a numerical species transport simulation for predictive Scenario A. The simulated species is assumed to be inert (no increase or decrease in concentrations related to chemical reactions, interaction with media, and other processes not related to mixing from groundwater movement or dispersion), and represents TDS in groundwater. Species transport media properties are listed in Table 11. Rainfall recharge was applied with a constant TDS concentration of 10 mg/L. The Upstream Finite Difference solver was employed.

Table 11. Species transport media properties adopted for simulation of TDS concentrations in the Lachlan Formation for predictive Scenario A.

| Layer | Initial TDS concentration* (mg/L) | Effective Porosity (-) | Dispersivity (m) |
|-----------------------|-----------------------------------|------------------------|------------------|
| Upper Cowra Formation | 20985 | 0.05 | 10 |
| Lower Cowra Formation | 9264 | 0.05 | 10 |
| Lachlan Formation | 1260 | 0.08 | 10 |

* See Section 2.7.

Figure 5.5 shows modelled and observed TDS concentrations at BLPR1 (using a conversion factor of 0.67 mg/L per uS/cm).

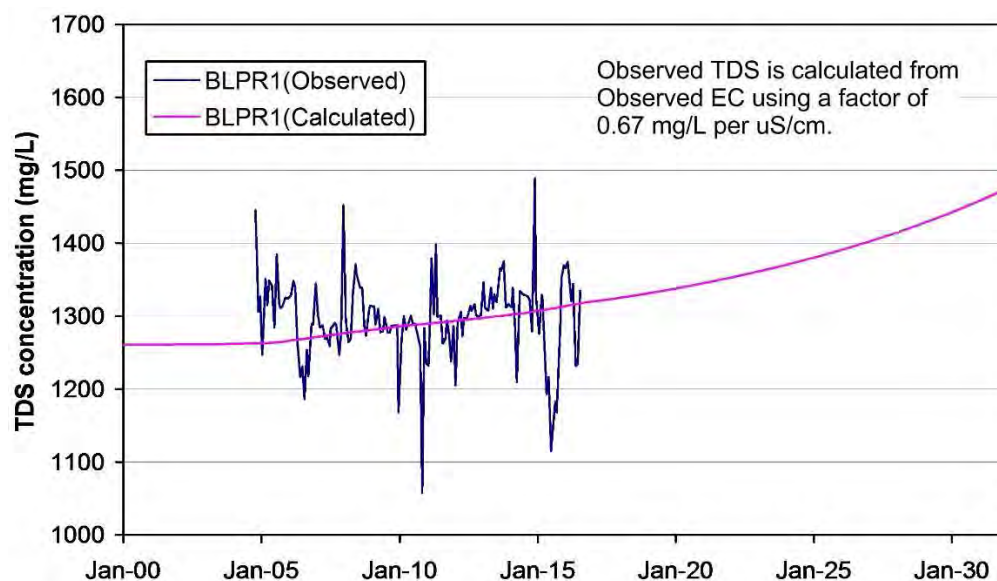

Figure 5.5. Modelled and observed TDS concentrations in the BCPB.

Observed and calculated TDS concentrations show reasonable agreement. Modelling results suggest TDS at BLPR1 will increase to around 1490 mg/L (an EC of around 2200 uS/cm) by 31 December 2032, an increase of about 20% from pre-mining concentrations. Simulation results with and without dispersion differ negligibly, and indicate the dominance of advective processes.

5.3.5. Post-mining water levels

When ESB and BCPB pumping stops, groundwater levels at GW036553 are predicted to recover to around 166 mAHD in 10 years (about 30 m below 1998 water levels), and would continue to gradually recover over time, to a level that is dependent on the amount historically pumped, private bore usage following mine closure, and climate. It may take significant amounts of time for water levels to recover to levels seen in the late 1990s (prior to the drought and onset of extensive pumping) because of the low rate of media recharge and continuing pumping for agricultural purposes.

6. Summary and conclusions

An existing model has been used to predict groundwater impacts associated with operation of the ESB and BCPB for the CGO under the Mine Life Modification. Predictive simulation results are based on significant assumptions regarding high-extraction private water bores in the area.

6.1. Predictive simulation results

Modelling results indicate that the BCPB can pump at a maximum rate of 5.1 ML/day, from 1 September 2016 to 31 December 2032 (with the ESB pumping at 1.5 ML/day), without causing the water level in trigger piezometer GW036553 to fall to below the trigger level of 134 mAHD.

For Scenario B (average total pumping from the BCPB and ESB of 4.43 and 0.71 ML/day respectively, between 1 September 2016 to 31 December 2032), the water level in trigger piezometer GW036553 stays above the trigger level during the simulation, except in 2031 (mining year 27) when large tonnages of oxide ore are processed. The lowest modelled water level is 125.0 mAHD. If the contingency trigger level in trigger piezometer GW036553 is reached during the oxide ore processing in 2031, Evolution may increase the proportion of licensed surface water extractions from the Lachlan River as required to maintain the BCPB groundwater levels above the contingency trigger.

Maximum drawdowns at the end of the CGO, for Scenarios A and B, are 41 m or less in the Lower Cowra Formation and 70 m or less in the Lachlan Formation. A maximum drawdown of about 32 m (in the Lower Cowra Formation) is modelled for GW029574, the only known water bore installed to a depth within the Lower Cowra Formation and within 15km of the BCPB. However, the bore is 88m deep and may be able to continue operation if the screen length is sufficiently long and optimally located.

Simple numerical transport simulation for Scenario A indicates EC at BLPR1 will increase by about 20%, by 31 December 2032, from pre-mining concentrations. This compares with an estimated increase of between 12% and 48% calculated in the previous study using a significantly simplified method.

At cessation of BCPB and ESB pumping, groundwater levels at GW036553 are predicted to recover to around 166 mAHD in 10 years (about 30 m below 1998 water levels).

6.2. Regulatory considerations

6.2.1. Additional allocation for the BCPB

Should license applications be considered by Evolution for additional groundwater allocations, the licensing would be subject to the water sharing plan for the Lachlan Unregulated and Alluvial Water Sources (which commenced on 14 September 2012 for a term of 10 years).

Under this plan, available water determinations are made at the start of each water year for aquifer access licences. 1 ML per unit of share component or lower amount is applied, as results from a growth in extractions response. A supplementary water access licence can be applied for if a growth in use response is triggered. These licences are issued to individuals based on history of extraction as established at the commencement of the Plan.

Licence applications will be assessed against the long-term average annual extraction limit of the Lachlan Alluvial Water Source, which is 94,168 ML/year.

The following points summarise the licensing situation for the CGO:

- Evolution currently holds 3650 units (ML) / annum in the Lachlan River Water Source.

- For the CGO under the Mine Life Modification, the estimated (most probable) maximum volumetric extraction from the Lachlan River Water Source is 2866 ML/annum (in calendar year 2031 or Mining Year 27).
- Evolution would continue to extract groundwater from the Lachlan River Water Source in accordance with existing licence entitlements, and in accordance with the contingency strategy as described in Section 6.2.3.

6.2.2. Aquifer Interference Policy

Merrick (2013) states that, according to Principle 14 of the NSW State Groundwater Policy Framework Document, “All activities or works that intersect an aquifer, and are not for the primary purpose of extracting groundwater, need an aquifer interference approval.”. Since the BCPB and ESB are for the primary purpose of extracting, and using, groundwater, no aquifer interference approval is needed. However, use of the BCPB and ESB are subject to regulatory requirements according to other legal instruments that may be in force. Specifically for the BCPB, a contingency strategy and mitigation measures are in place as discussed below.

6.2.3. Lachlan Formation Water Source

Contingency strategy

The groundwater level in the Lachlan Formation in the BCPB area is monitored on a continuous basis by the NSWOW using its groundwater monitoring bore on Burcher Road (GW036553). Contingency measures have been developed for implementation when water levels reach an elevation of either 137.5mAHD (Trigger Level A) or 134mAHD (Trigger Level B). These trigger levels were developed in consultation with NSWOW and other water users within the Bland Creek Palaeochannel, including stock and domestic users and irrigators. The following contingency measures are understood to be associated with each Trigger Level:

- In the event that the groundwater level in GW036553 is below 137.5 mAHD, one or more of the following contingency measures will be implemented in consultation with the NSWOW:
 - Investigate the groundwater level in the Trigalana bore (GW702286) or any other impacted stock and domestic bores.
 - Determine the pump setting in relevant stock and domestic bores.
 - Determine the drawdown rate in GW702286 and other impacted stock and domestic bores.
 - Develop an impact mitigation plan for impacted stock and domestic bores, and/or set up an alternative water supply for the owner of GW702286 and other owners of stock and domestic bores, if necessary.
- In the event that the groundwater level in GW036553 is below 134 mAHD, one or both of the following contingency measures will be implemented in consultation with the NSWOW:
 - Alter the pumping regime to maintain the water level in the impacted stock and domestic bores.
 - Maintain a water supply to the owner/s of impacted stock and domestic bores.

Mitigation measures

Prior to the drought last decade, stock and domestic water supplies were generally drawn from surface water delivered through the Jemalong Irrigation Limited irrigation channel network. The reduced availability and increased cost of this water, driven by reduced rainfall from around 2002 onwards, led to establishment of stock/domestic bores which utilised the Lachlan Formation aquifer.

Several consortia were established to share the costs of bore installation and to deliver the water across multiple properties.

Evolution was independently approached by various parties for assistance in upgrading the pumping systems such that their design capacity could be met independently of the abstraction from the Lachlan Formation. The known schemes are listed below (see Appendix E for locations):

- Moora Moora (GW702262).
- West Plains (GW702100).
- Trigalana (GW702286, also known as Trigalana West).
- Trigalana East.

Each of the schemes is understood to comprise the following key elements:

- A single bore equipped with a submersible pump.
- Above-ground storage tanks located near the bore.
- A surface-mounted pump to pressurize the pipeline system.
- A pipeline system with control valves at the user offtake.

The Muffet bore (GW701958) is understood to have provided stock water on a single property, through a solar-powered pumping system. Other private, single-farm systems are reported to be powered by solar, diesel, and mains powered pumps.

It is understood that the following measures were implemented by Evolution for ameliorating the impacts of pumping at the BCPB on stock/domestic bores:

- From 2006 to 2007:
 - Moora Moora: Replacement of the pump, installation of a new pump to a greater depth and upgrade of the electrical power supply to enable the system to maintain design flow.
 - West Plains and Trigalana: Provision of water through a metered polyethylene pipeline direct to the stock water tanks.
 - Muffet: Replacement of an existing solar powered submersible pump with a new pump of larger capacity, setting of the new pump to a greater depth, and upgrade of the solar panel array to increase its electrical output.
- During 2011:
 - West Plains: The bore failed and Evolution paid for replacement of the bore in mid-2011. The bore was operating by the fourth quarter of 2011.
 - Isolation of the West Plains and West Trigalana schemes from the direct supply of water from Evolution's pipeline (although water could still be supplied in an emergency since the pipelines remain in place).

6.2.4. Cowra Formation Water Source

Modelling results indicate a maximum predicted drawdown of about 32 m at bore GW029574, the only known water bore installed to a depth within the Lower Cowra Formation and within 15km of the BCPB. However, the bore is 88m deep and may be able to continue operation if the screen length is sufficiently long and optimally located. If not, contingency measures may be required for this bore.

7. Limitations

Predictive simulations have been undertaken using significant assumptions for high-extraction private bores in the Maslin and Billabong areas. These bores have a majority contribution to drawdowns at GW036597 and GW036611, but a minority contribution to drawdown at GW036553. Where actual extraction rates may differ, even by small amounts, from the assumptions, the potential for significant departures of observations from model results increases substantially.

In addition, predictive transport simulations have been undertaken using significant assumptions for species transport parameters which were not calibrated to observations. This adds a higher level of uncertainty to results, especially at longer simulated times. The layer discretisation in the model only allows the variation in TDS with depth (a continuum) to be described by three values (one for each model layer).

Predictive results are subject to the uncertainty inherent in any numerical modelling. The numerical model is necessarily a simplification of the real system and relies on calibration to observation data to produce predictive results. The results are estimates only and may differ significantly from future observations. Also, actual future extraction from the BCPB and ESB may differ from that adopted for predictive simulations.

8. Recommendations

The numerical model requires updating and verification on a regular basis for it to be able to be used as an effective predictive tool. Model recalibration may be necessary from time to time, using additional observations as they are collected.

9. References

- Anderson J, Gates G, and Mount TJ. 1993. Hydrogeology of the Jemalong and Wyldes Plains Irrigation Districts. Technical Services Division, Department of Water Resources. Report TS93.045. August.
- British Institute of Hydrology. 1980a. Research report, v. 1 of Low flow studies: Wallingford, United Kingdom, Institute of Hydrology, 42 p.
- British Institute of Hydrology. 1980b. Catchment characteristic estimation manual, v. 3 of Low flow studies: Wallingford, United Kingdom, Institute of Hydrology, 27 p.
- Carrara EA, Weaver TR, Cartwright I, and Cresswell RG. 2004. 14C and 36Cl as indicators of groundwater flow, Bland Catchment, NSW. Proceedings of the Eleventh International Symposium on Water-Rock Interaction WRI-11, Saratoga Springs, NY, 27 June - 2 July 2004. Pages:377-381
- Coffey Geotechnics Pty Ltd. 2013. Final Hydrogeological Assessment, CGO Extension Modification. Report GEOTLCOV21910AW-AI, prepared for Barrick. September.
- Coffey Geosciences Pty Ltd. 2006. Cowal Gold Mine Groundwater Supply Modelling Study: Model Calibration. Report S21910/02AK prepared for Barrick Australia Limited. October.
- Coffey Partners International Pty Ltd. 1995a. Outside Borefield to Mine Water Transmission Pipeline Feasibility Study. Report No. G255/22-AB. February.
- Coffey Partners International Pty Ltd. 1995b. Outside Borefield Feasibility Study for Lake Cowal Project. Report No. G255/24-AJ. February.
- Coffey Partners International Pty Ltd. 1995c. Results of Additional Hydrogeological Modelling and Borefield Study – Lake Cowal Gold Mine. Report No. G255/29-AD. March
- Coffey Partners International Pty Ltd. 1995d. Lake Cowal Project – Hydrogeological Modelling and Dewatering Study. Report No. G255/28-AF. April
- Coffey Partners International Pty Ltd. 1997. Hydrogeological Assessment – Lake Cowal. Report No.G255/41-AO.
- Coffey Partners International. 1994a. Outside Borefield Study for Endeavour 42 Gold Prospect. Report No. G255/18-AD. June.
- Coffey Partners International. 1994b. Groundwater Modelling Study, Jemalong Wyldes Plain. Report G375/2-AB. November.
- Cook PG, Leaney FW, and Jolly ID. 2001. Groundwater recharge in the Mallee Region, and salinity implications for the Murray River – A review. CSIRO Land and Water Technical Report 45/01. November.
- Cooper HH and Jacob CE. 1946. A generalized graphical method for evaluating formation constants and summarizing well field history. American Geophysical Union Transcripts, Volume 27, p. 526 - 534.
- Groundwater Consulting Services Pty Ltd. 2006. Jemalong Water Supply Borefield Installation and Testing, Cowal Gold Project, West Wyalong, New South Wales. Report compiled for Barrick Australia Limited. August.
- Hawkes GE. 1998. Hydrogeology of the Proposed Lake Cowal Gold Mine, NSW. Unpublished MSc Thesis. University of Technology, Sydney.

- Merrick NP. 2013. How does the Aquifer Interference Policy affect groundwater assessments ?. Presentation to NSW IAH, 12 March 2013.
- Merrick NP. 1989. Lower Namoi Valley Groundwater Model. Heritage Computing.
- North Limited. 1998. Environmental Impact Statement, Cowal Gold Project. Prepared by Resource Strategies. March.
- Ross JB. 1982. Interim report on the Water Resources Commission investigation – Drilling and current observation bore network in the Upper Lachlan Valley. WRC Hydrogeological Report 1982/2.
- SNC-Lavalin Australia. 2003. Cowal Gold Project Geotechnical Investigation Report. Report 334371-0000-4GRA-0001 prepared for Barrick Gold of Australia. December.
- Van der Lely A. 1993. Channel seepage from Warroo Main Canal, Jemalong Irrigation District. NSW Department of Water Resources (Murrumbidgee Region) Technical Report No. 93/04. October.
- Wahl KL and Wahl TL. 1995. Determining the flow of Comal Springs at New Braunfels, Texas, in Proceedings of Texas Water 95, August 16–17, 1995, San Antonio, Tex.: American Society of Civil Engineers, p. 77-86.
- Williams BG. 1993. The shallow groundwater hydrology of the Jemalong – Wyldes Plains Irrigation Districts. NSW Department of Agriculture. March.



Important information about your **Coffey** Report

As a client of Coffey you should know that site subsurface conditions cause more construction problems than any other factor. These notes have been prepared by Coffey to help you interpret and understand the limitations of your report.

Your report is based on project specific criteria

Your report has been developed on the basis of your unique project specific requirements as understood by Coffey and applies only to the site investigated. Project criteria typically include the general nature of the project; its size and configuration; the location of any structures on the site; other site improvements; the presence of underground utilities; and the additional risk imposed by scope-of-service limitations imposed by the client. Your report should not be used if there are any changes to the project without first asking Coffey to assess how factors that changed subsequent to the date of the report affect the report's recommendations. Coffey cannot accept responsibility for problems that may occur due to changed factors if they are not consulted.

Subsurface conditions can change

Subsurface conditions are created by natural processes and the activity of man. For example, water levels can vary with time, fill may be placed on a site and pollutants may migrate with time. Because a report is based on conditions which existed at the time of subsurface exploration, decisions should not be based on a report whose adequacy may have been affected by time. Consult Coffey to be advised how time may have impacted on the project.

Interpretation of factual data

Site assessment identifies actual subsurface conditions only at those points where samples are taken and when they are taken. Data derived from literature and external data source review, sampling and subsequent laboratory testing are interpreted by geologists, engineers or scientists to provide an opinion about overall site conditions, their likely impact on the proposed development and recommended actions. Actual conditions may differ from those inferred to exist, because no professional, no matter how qualified, can reveal what is hidden by earth, rock and time. The actual interface between materials may be far more gradual or abrupt than assumed based on the facts obtained. Nothing can be done to change the actual site conditions which exist, but steps can be taken to reduce the impact of unexpected conditions. For this reason, owners should retain the services of Coffey through the development stage, to identify variances, conduct additional tests if required, and recommend solutions to problems encountered on site.

Your report will only give preliminary recommendations

Your report is based on the assumption that the site conditions as revealed through selective point sampling are indicative of actual conditions throughout an area. This assumption cannot be substantiated until project implementation has commenced and therefore your report recommendations can only be regarded as preliminary. Only Coffey, who prepared the report, is fully familiar with the background information needed to assess whether or not the report's recommendations are valid and whether or not changes should be considered as the project develops. If another party undertakes the implementation of the recommendations of this report there is a risk that the report will be misinterpreted and Coffey cannot be held responsible for such misinterpretation.

Your report is prepared for specific purposes and persons

To avoid misuse of the information contained in your report it is recommended that you confer with Coffey before passing your report on to another party who may not be familiar with the background and the purpose of the report. Your report should not be applied to any project other than that originally specified at the time the report was issued.

Interpretation by other design professionals

Costly problems can occur when other design professionals develop their plans based on misinterpretations of a report. To help avoid misinterpretations, retain Coffey to work with other project design professionals who are affected by the report. Have Coffey explain the report implications to design professionals affected by them and then review plans and specifications produced to see how they incorporate the report findings.



Important information about your **Coffey Report**

Data should not be separated from the report*

The report as a whole presents the findings of the site assessment and the report should not be copied in part or altered in any way. Logs, figures, drawings, etc. are customarily included in our reports and are developed by scientists, engineers or geologists based on their interpretation of field logs (assembled by field personnel) and laboratory evaluation of field samples. These logs etc. should not under any circumstances be redrawn for inclusion in other documents or separated from the report in any way.

Geoenvironmental concerns are not at issue

Your report is not likely to relate any findings, conclusions, or recommendations about the potential for hazardous materials existing at the site unless specifically required to do so by the client. Specialist equipment, techniques, and personnel are used to perform a geoenvironmental assessment. Contamination can create major health, safety and environmental risks. If you have no information about the potential for your site to be contaminated or create an environmental hazard, you are advised to contact Coffey for information relating to geoenvironmental issues.

Rely on Coffey for additional assistance

Coffey is familiar with a variety of techniques and approaches that can be used to help reduce risks for all parties to a project, from design to construction. It is common that not all approaches will be necessarily dealt with in your site assessment report due to concepts proposed at that time. As the project progresses through design towards construction, speak with Coffey to develop alternative approaches to problems that may be of genuine benefit both in time and cost.

Responsibility

Reporting relies on interpretation of factual information based on judgement and opinion and has a level of uncertainty attached to it, which is far less exact than the design disciplines. This has often resulted in claims being lodged against consultants, which are unfounded. To help prevent this problem, a number of clauses have been developed for use in contracts, reports and other documents. Responsibility clauses do not transfer appropriate liabilities from Coffey to other parties but are included to identify where Coffey's responsibilities begin and end. Their use is intended to help all parties involved to recognise their individual responsibilities. Read all documents from Coffey closely and do not hesitate to ask any questions you may have.

* For further information on this aspect reference should be made to "Guidelines for the Provision of Geotechnical information in Construction Contracts" published by the Institution of Engineers Australia, National headquarters, Canberra, 1987.

Drawings

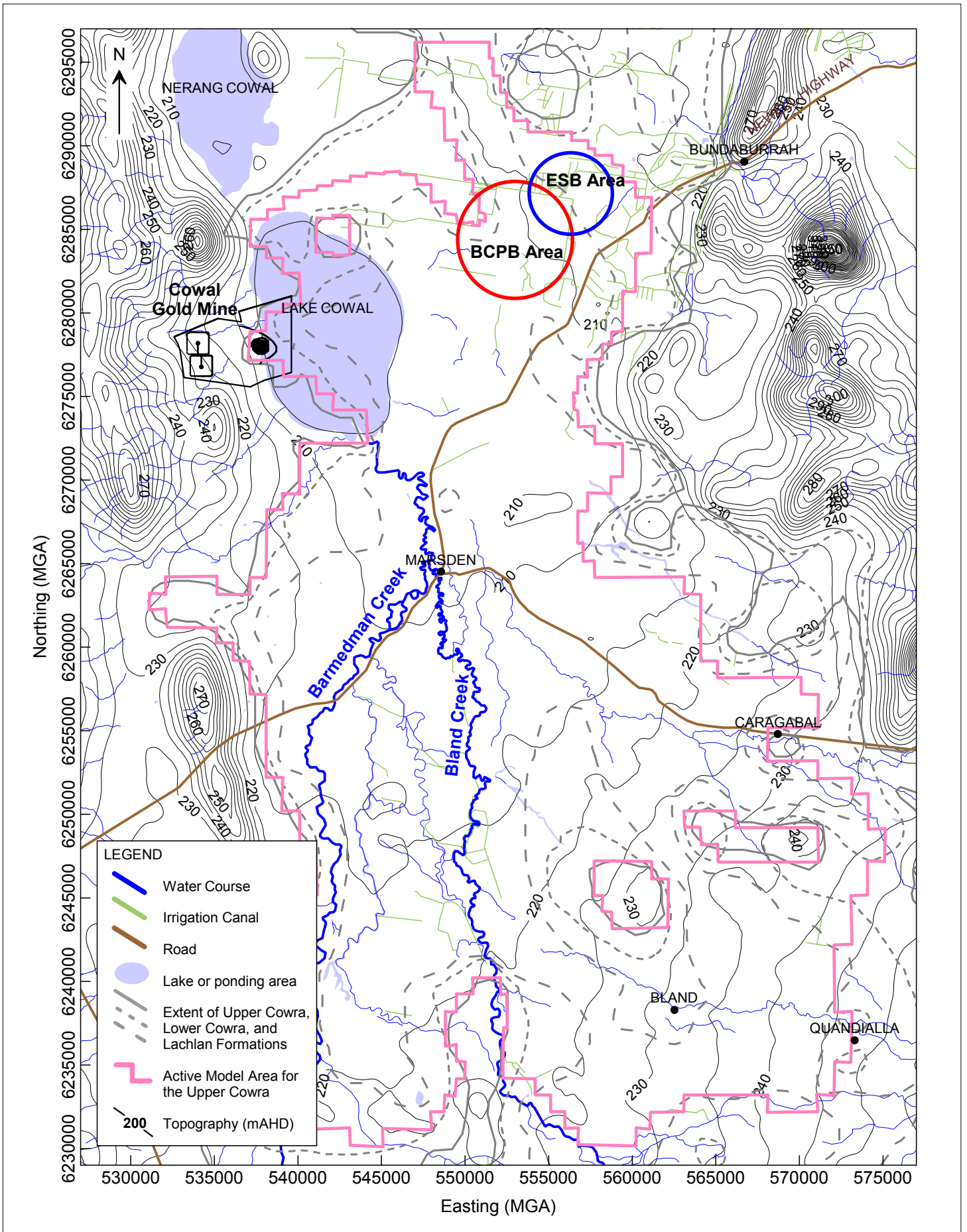

| | | | | | | |
|---------------|------------|---|-------------|--|------------|------------------|
| drawn | PT |  A TETRA TECH COMPANY | client: | Evolution Mining (Cowl) Pty Limited | | |
| approved | | | project: | Cowl Gold Operations Mine Life Modification Groundwater Assessment | | |
| date | 9 Nov 2016 | | title: | Regional Locality Map | | |
| scale | 1:300,000 | | project no: | GEOTLCOV21910BG | figure no: | Drawing 1 |
| original size | A4 | | | | | |

Appendix A - Specific Capacity Analysis

Specific capacity (Sc) is the pumping rate divided by the drawdown in the pumped bore at a specified time. The time is usually taken as 1 day, since most tests are of this duration.

An analysis is undertaken using tests where temporal drawdown data are available. For each test, Sc is calculated at 1 day. Transmissivity is interpreted from temporal drawdown at the pumped bore using the Cooper and Jacob (1946) method for confined conditions (Tj). The quantity $(T_j - S_c)/T_j$ is then plotted against pumping rate and the relationship approximated with a trendline. This relationship is then used to convert Sc for tests where temporal drawdown is unavailable (the majority of government records). The method assumes the bores in the database are approximately similar in hydraulic behaviour (well loss component), and that dissimilarities in screened lithology are minor.

Table 1 lists the pumping tests (from 9 bores) used to find a relationship, and Figure 1 shows the resulting relationship. For some tests, the drawdown at 1 day was either unavailable or could not be estimated. This adds additional approximation to the fitted line.

Table 1. Bore tests used for specific capacity analysis.

| Bore | Screened Formation | Registration Number | Pumping Rate (m3/day) | Test Duration (hours) | Tj* (m2/day) | Interpretation | Specific Capacity | | | (Tj-Sc)/Tj |
|-----------------|--------------------|---------------------|-----------------------|-----------------------|--------------|--------------------------|-------------------|-------|-------------|------------|
| | | | | | | | Draw-down (m) | Time | Sc (m2/day) | |
| CGO BCPB Bore 1 | Lachlan | GW701660 | 2894 | 0.4 | 662 | Coffey 2008 | 9.0 | 1 day | 322 | 0.514 |
| CGO BCPB Bore 2 | Lachlan | GW701659 | 4752 | 24 | 870 | Coffey 2008 | 9.1 | 1 day | 522 | 0.400 |
| CGO BCPB Bore 3 | Lachlan | GW701658 | 4752 | 24 | 1242 | Coffey 2008 | 12.1 | 1 day | 393 | 0.684 |
| CGO BCPB Bore 4 | Lachlan | GW701657 | 4752 | 24 | 870 | Coffey 2008 | 14.5 | 1 day | 328 | 0.623 |
| BLRP2 Test 1 | Lachlan | | 2678 | 48 | 460 | Coffey 1994 (G255/18-AD) | 11.1 | 1 day | 241 | 0.476 |
| BLRP2 Test 2 | Lachlan | | 5702 | 168 | 482 | Coffey 1995 (G255/24-AJ) | 19.0 | 1 day | 300 | 0.377 |
| Duff 2009 | Lower Cowra | GW702230 | 1452 | 91 | 98 | GCS 2010 (BARR010) | 23.0 | End | 63 | 0.356 |
| Duff 2004 | Lower Cowra | GW702230 | 1597 | 24 | 104 | Coffey 2008 | 34.6 | 1 day | 46 | 0.556 |
| PBA | Upper Cowra | | 173 | 53 | 248 | Coffey 1994 (G375/1-AF) | 1.0 | End | 173 | 0.303 |
| PBB | Upper Cowra | | 86 | 5 | 243 | Coffey 1994 (G375/1-AF) | 0.4 | End | 237 | 0.023 |
| PBC | Upper Cowra | | 51 | 44 | 76 | Coffey 1994 (G375/1-AF) | 0.8 | End | 61 | 0.203 |

*Tj = Transmissivity using Cooper Jacob (1946) method.

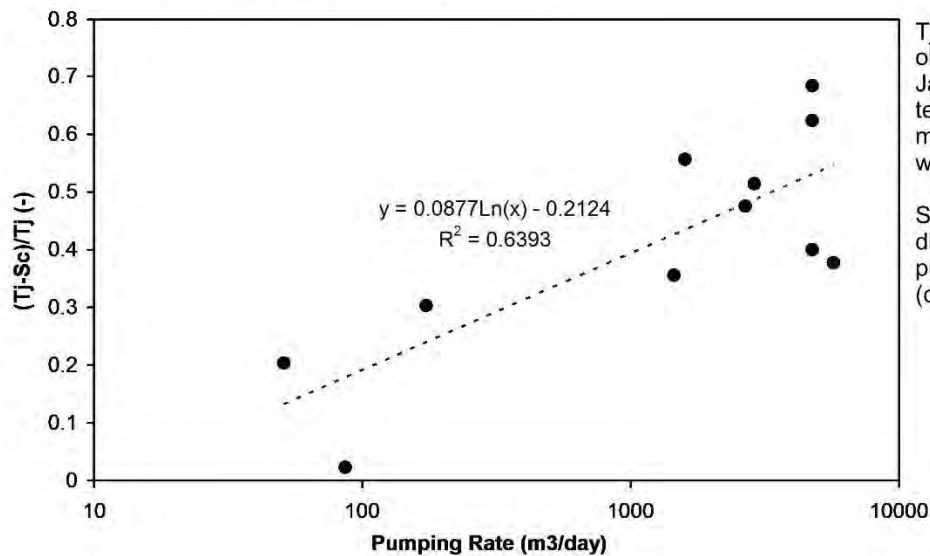

Tj denotes the transmissivity obtained using the Cooper and Jacob (1946) method using temporal drawdown measurements from the pumped well.

Sc denotes the pumping rate divided by the drawdown in the pumped well at a specified time (commonly 1 day).

Figure 1. Results of specific capacity analysis for tests in Table 1.

Appendix B - Groundwater Monitoring Network

Bland Creek Palaeochannel Monitoring Bore Network

| Piezometer / Bore | Owner | Collar Elevation (mAHD) | Easting (mMGA) | Northing (mMGA) | Stratum | Screen (mbgl) | | Comment |
|-------------------|-----------|-------------------------|----------------|-----------------|---------|---------------|-----|--|
| | | | | | | From | To | |
| BLPR1-Ln | Evolution | 211.14 | 553858 | 6285166 | Ln | 102 | 110 | BCPB monitoring |
| BLPR2-Ln | Evolution | 209.16 | 553044 | 6285330 | Ln | 106 | 126 | BCPB monitoring |
| BLPR3-LC | Evolution | 210.50 | 553417 | 6289305 | LC | 72 | 84 | BCPB monitoring |
| BLPR4-Ln | Evolution | 210.77 | 553117 | 6287305 | Ln | 94 | 110 | BCPB monitoring |
| BLPR5-Ln | Evolution | 209.61 | 552392 | 6282505 | Ln | 107 | 120 | BCPB monitoring |
| BLPR6-Ln | Evolution | 210.09 | 553592 | 6283955 | Ln | 97 | 115 | BCPB monitoring |
| BLPR7-Ln | Evolution | 210.47 | 555292 | 6283405 | Ln | 103 | 133 | BCPB monitoring |
| PZ01-UC/LC | Evolution | 210.71 | 555703 | 6287188 | UC/LC | 20 | 80 | ESB Monitoring. Decommissioned May 2012. |
| PZ02-UC/LC | Evolution | 210.69 | 556267 | 6288075 | UC/LC | 18 | 78 | ESB Monitoring. |
| PZ05-UC/LC | Evolution | 211.05 | 555984 | 6286935 | UC/LC | 18 | 78 | ESB Monitoring. |
| PZ06 | Evolution | 212.09 | 557239 | 6289189 | | | | ESB Monitoring. Screen interval unknown. Probably UC/LC or LC. |
| PZ07 | Evolution | 211.80 | 557343 | 6288365 | | | | ESB Monitoring. Screen interval unknown. Probably UC/LC or LC. |
| PZ08 | Evolution | 210.97 | 556465 | 6286840 | | | | ESB Monitoring. Screen interval unknown. Probably UC. |
| PZ09-UC | Evolution | 211.19 | 556580 | 6288433 | UC | 13 | 16 | ESB Monitoring |
| PZ10-LC | Evolution | 211.19 | 556584 | 6288435 | UC/LC | 48 | 51 | ESB Monitoring |
| PZ11-LC | Evolution | 211.33 | 556588 | 6288437 | LC | 60 | 64 | ESB Monitoring |
| SB03 | Evolution | 211.57 | 557116 | 6289198 | UC/LC | 46 | 64 | ESB Monitoring (outfitted as pumping bore but not pumped) |
| SB04 | Evolution | 211.68 | 557324 | 6288376 | LC | 59 | 65 | ESB Monitoring (outfitted as pumping bore but not pumped) |
| SB05 | Evolution | 211.06 | 556447 | 6286849 | LC | 58 | 64 | ESB Monitoring (outfitted as pumping bore but not pumped) |
| Bore16-UC | JIL | 211.06 | 553425 | 6288550 | UC | Water table | | Screen interval unknown. Straddles water table. |
| WT50-UC | JIL | 208.56 | 551121 | 6281522 | UC | Water table | | Screen interval unknown. Straddles water table. |
| GW036524-UC | NSWOW | 207.37 | 546337 | 6286862 | UC | 15 | 17 | Backfilled 89m. Water levels appear to be representative. |
| GW036553-Ln | NSWOW | 209.33 | 552434 | 6285773 | Ln | 118 | 126 | |
| GW036594-LC | NSWOW | 208.79 | 549558 | 6286186 | LC | 69 | 71 | Pipes in same drillhole, but SWLs not the same. |
| GW036594-UC | NSWOW | 208.79 | 549558 | 6286186 | UC | 11 | 15 | Pipes in same drillhole, but SWLs not the same. |
| GW036595-LC | NSWOW | 209.32 | 547929 | 6263905 | LC | 85 | 87 | Backfilled 45m. SWLs appear to be representative. |
| GW036596-LC | NSWOW | 209.27 | 550938 | 6264661 | LC | 64 | 66 | Pipes in separate drillholes. |

| Piezometer / Bore | Owner | Collar Elevation (mAHD) | Easting (mMGA) | Northing (mMGA) | Stratum | Screen (mbgl) | | Comment |
|----------------------|---------|-------------------------|----------------|-----------------|---------|---------------|-----|--|
| | | | | | | From | To | |
| GW036596-Ln | NSWOW | 209.00 | 550938 | 6264661 | Ln | 85 | 87 | Pipes in separate drillholes. |
| GW036597-Ln | NSWOW | 209.81 | 544505 | 6263713 | Ln | 95 | 99 | Pipes in same drillhole. SWLs same as 36597-LC. Only Ln screen used. |
| GW036605-Ln | NSWOW | 221.11 | 554028 | 6241420 | Ln | 80 | 86 | |
| GW036606-Ln | NSWOW | 234.18 | 564753 | 6238189 | Ln | 99 | 105 | |
| GW036609-Ln | NSWOW | 210.92 | 554624 | 6285396 | Ln | 106 | 113 | |
| GW036610-LC | NSWOW | 209.33 | 549088 | 6264456 | LC | 64 | 68 | Backfilled 45m. Water levels appear to be representative. |
| GW036611-Ln | NSWOW | 209.09 | 553937 | 6264823 | Ln | 107 | 113 | |
| GW036613-LC | NSWOW | 213.41 | 541663 | 6263705 | LC | 35 | 45 | Backfilled 33m. Screen in UC but SWLs interpreted as LC. |
| GW036700-LC | NSWOW | 209.03 | 555433 | 6264788 | LC | 65 | 75 | No backfill. |
| GW039379-Ln | NSWOW | 223.99 | 557312 | 6240441 | Ln | 74 | 100 | Directly coincident with 36604-Ln (36604-Ln not used). |
| GW090093-LC | NSWOW | 210.19 | 549832 | 6294377 | LC | 60 | 66 | Pipes in separate drillholes. |
| GW090093-Ln | NSWOW | 210.12 | 549832 | 6294377 | Ln | 130 | 136 | Pipes in separate drillholes. |
| GW090093-UC | NSWOW | 210.05 | 549832 | 6294377 | UC | 5 | 11 | Pipes in separate drillholes. |
| Coles(GW701579) | Private | 209.20 | 553767 | 6269660 | Ln | 107 | 110 | |
| Koreela(GW702262) | Private | 212.80 | 549449 | 6293272 | Ln | 117 | 125 | Also in model as a pumping bore. |
| Muffet(GW701958) | Private | 209.00 | 556272 | 6270630 | Ln | 88 | 93 | Also in model as a pumping bore. |
| Trigalana(GW702286) | Private | 208.30 | 555900 | 6279959 | Ln | 102 | 113 | Also in model as a pumping bore. |
| Warrakimbo(GW701681) | Private | 208.00 | 552812 | 6266221 | Ln | | | Very close to Maslin Pumping Bore. |

Glossary: JIL denotes Jemalong Irrigation Limited. mbgl denotes metres below ground level. UC denotes Upper Cowra Formation. LC denotes Lower Cowra Formation. Ln denotes Lachlan Formation. SWL denotes standing water level.

Bland Creek Palaeochannel Monitoring Piezometer Network

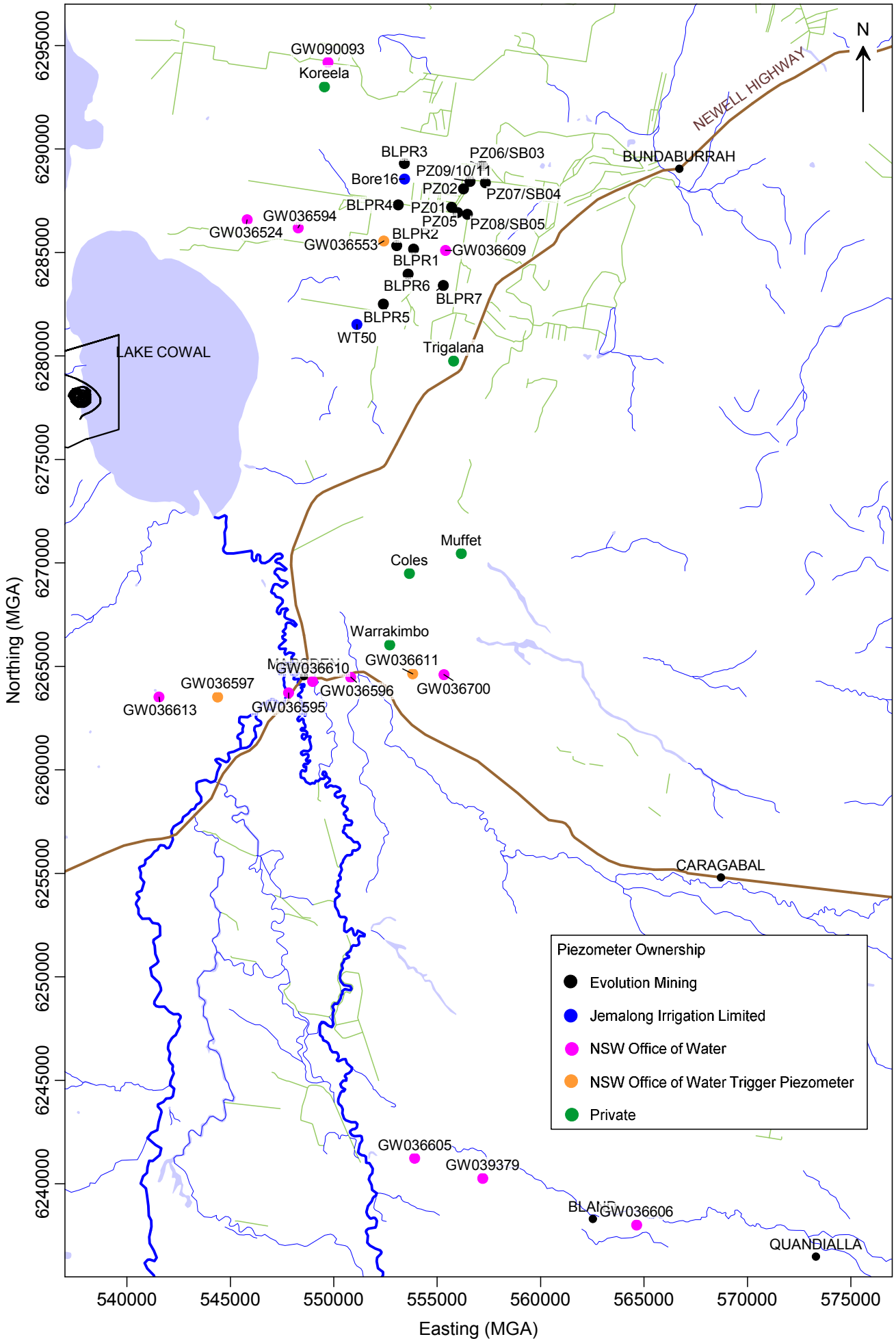

Appendix C – Interpolated Hydraulic Head Surfaces

Interpolated Hydraulic Head Surfaces for the Upper Cowra Formation

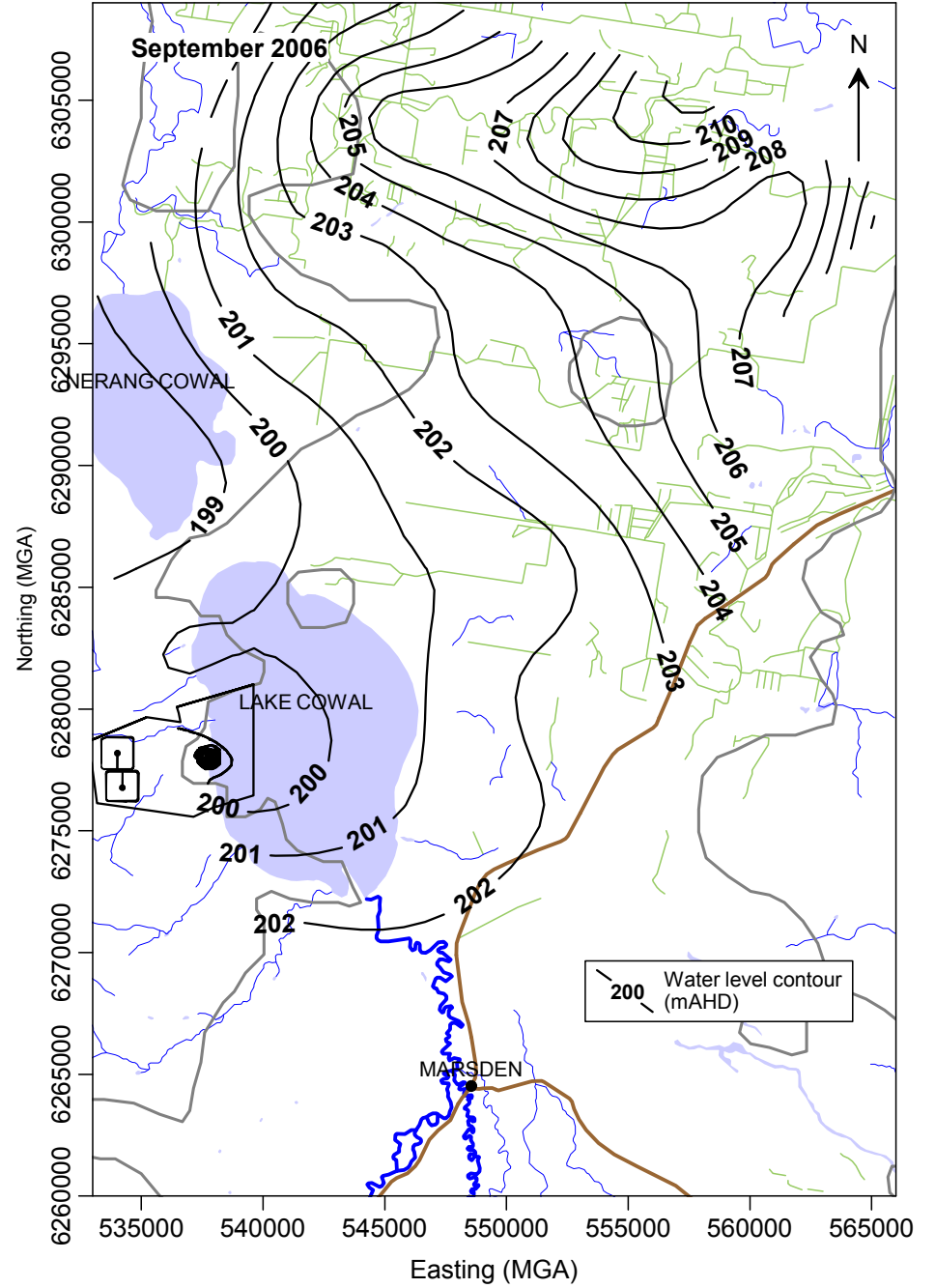
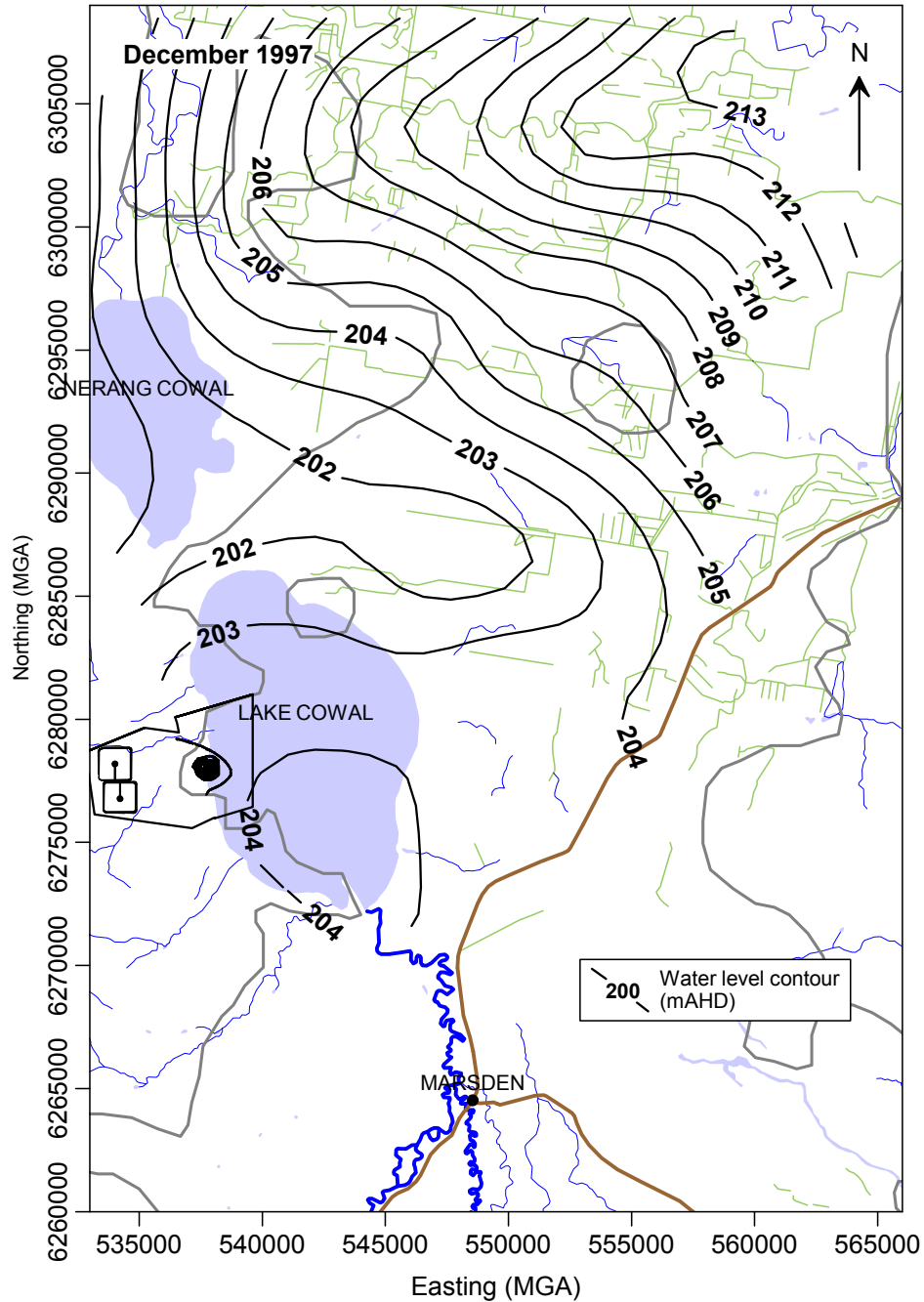

Interpolated Hydraulic Head Surfaces for the Lower Cowra Formation

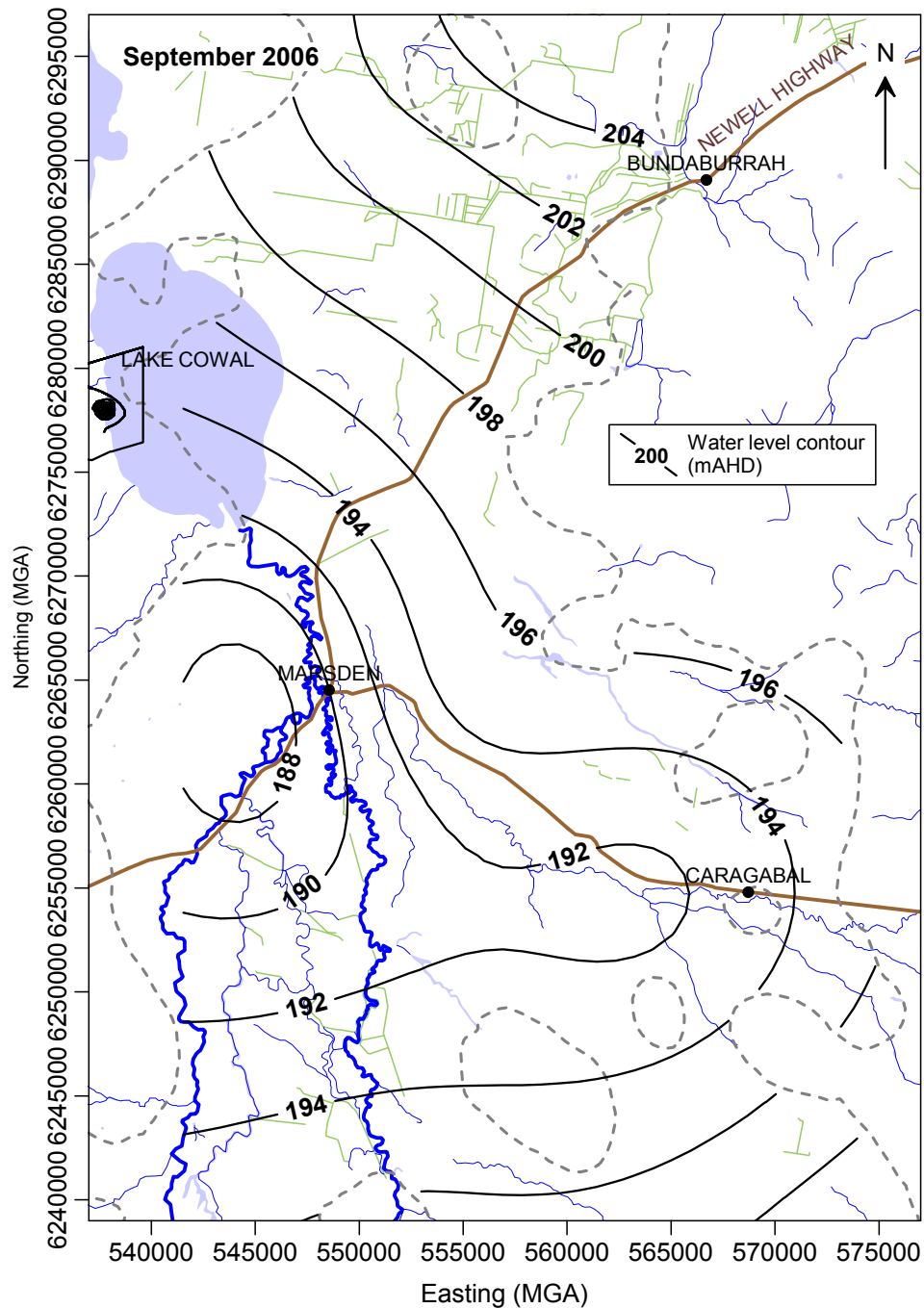
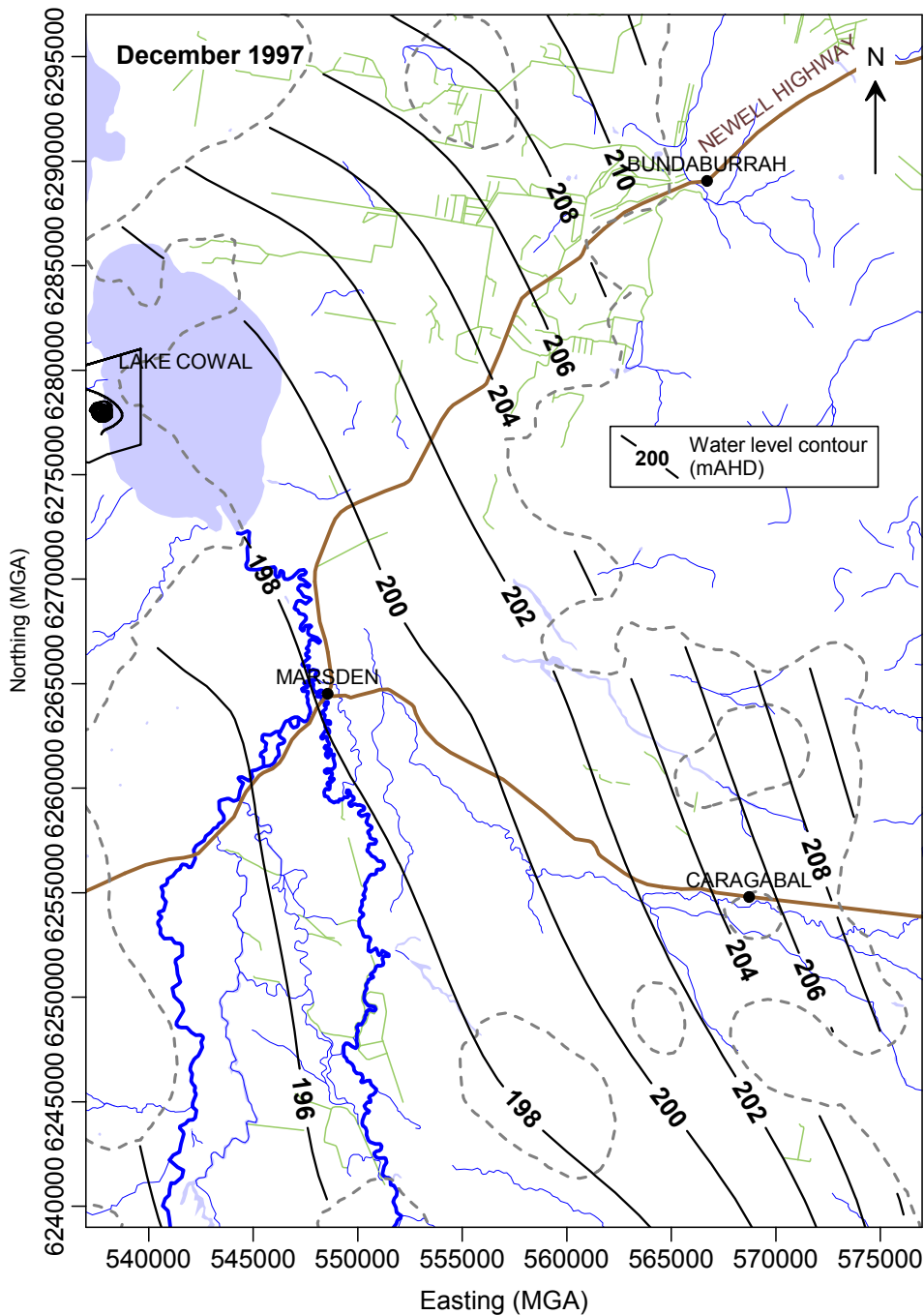

Interpolated Hydraulic Head Surfaces for the Lachlan Formation

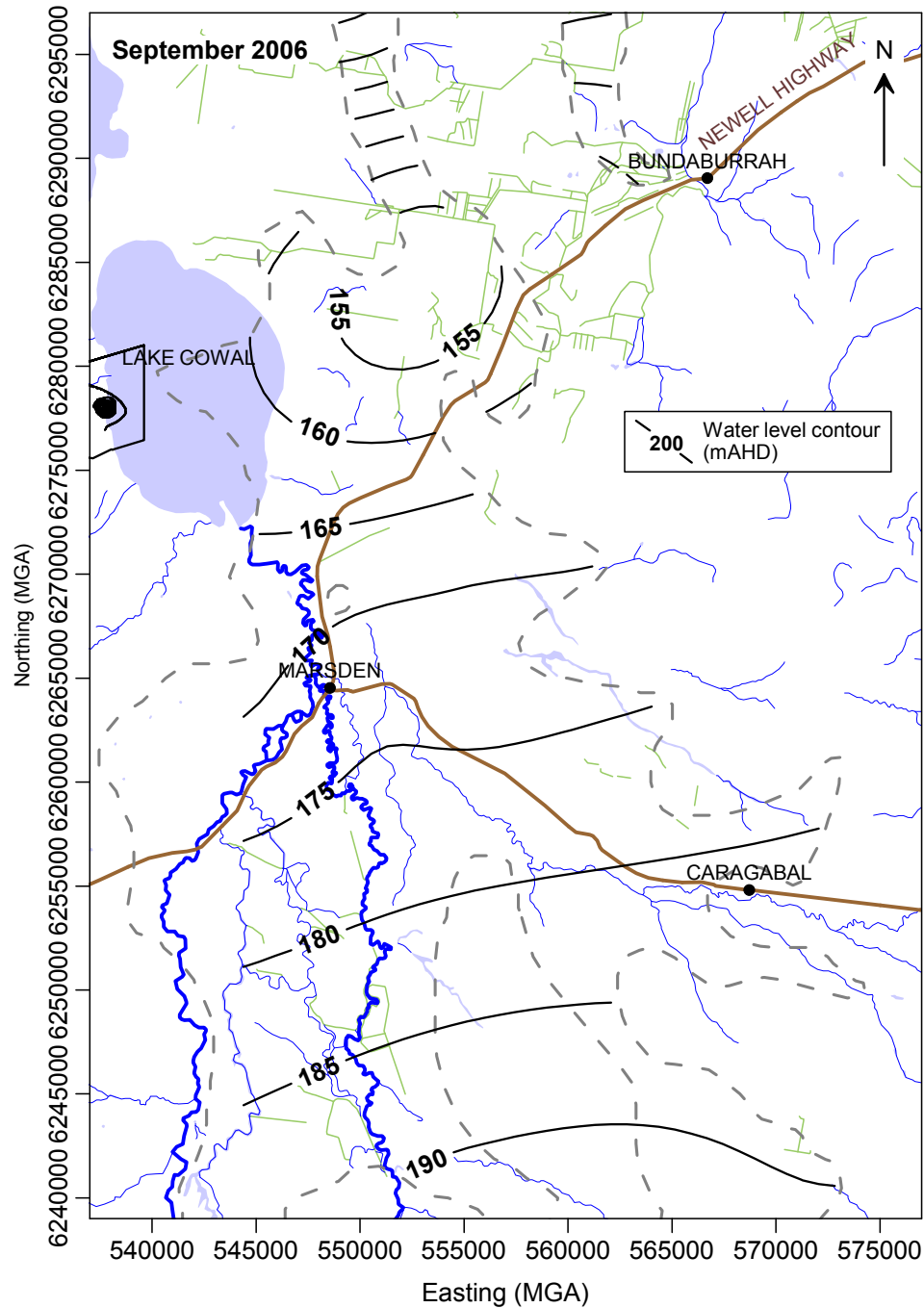
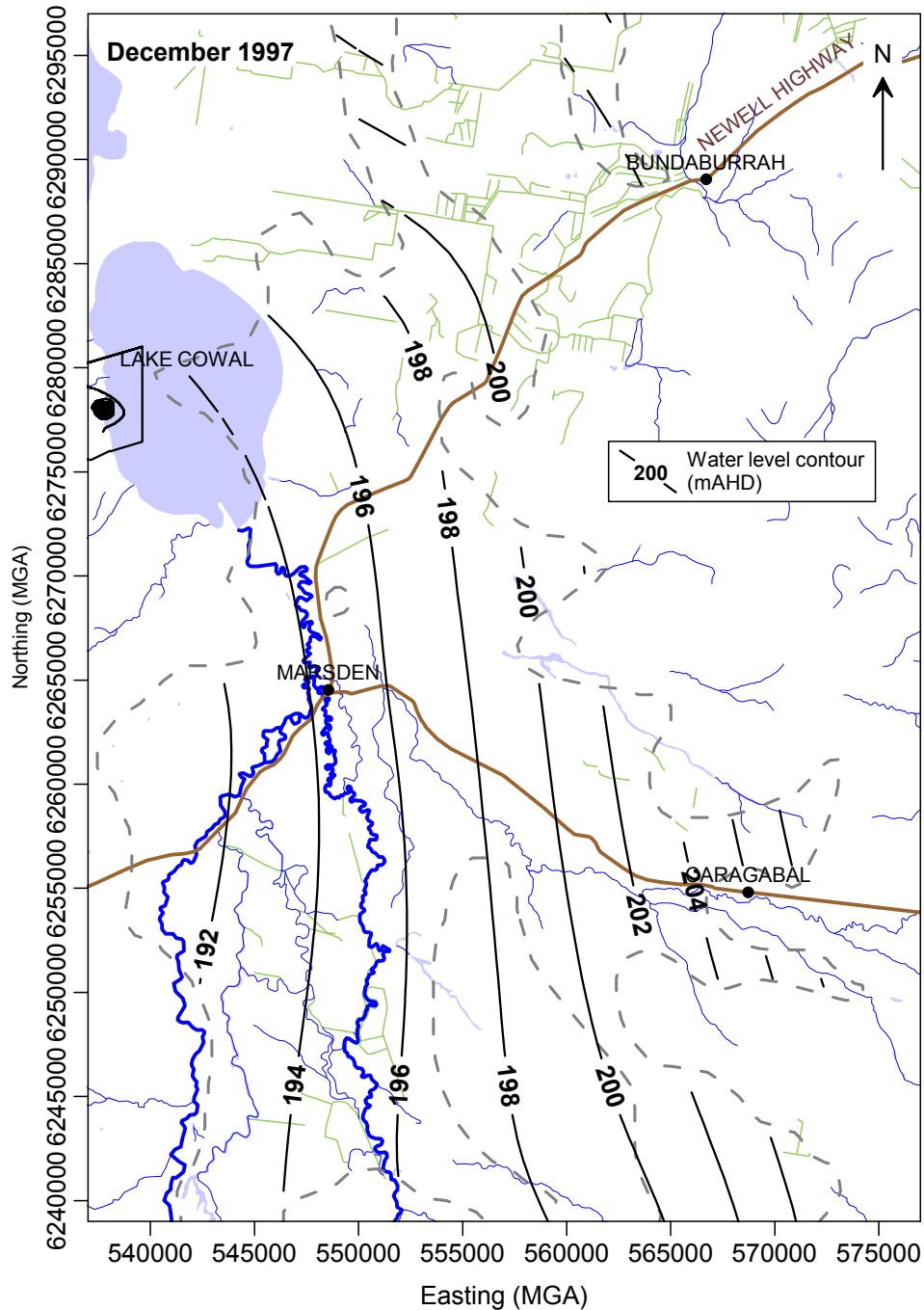

Appendix D - Groundwater Electrical Conductivity Averages

Groundwater Electrical Conductivity Database

| Bore | Log-Average EC (uS/cm) | Average EC minus one standard deviation* (uS/cm) | Average EC plus one standard deviation* (uS/cm) | Depth (mbgl) | Data Source |
|----------------------|------------------------|--|---|--------------|---|
| BLPR1 (2004 to 2016) | 1933 | 1848 | 2023 | 106 | BLPR series averages. Barrick / EM. |
| BLPR2 (2004 to 2016) | 2400 | 1733 | 3323 | 116 | |
| BLPR3 (2004 to 2016) | 4979 | 4810 | 5153 | 78 | |
| BLPR4 (2005 to 2016) | 2038 | 1878 | 2211 | 102 | |
| BLPR5 (2005 to 2016) | 2473 | 2305 | 2653 | 114 | |
| BLPR6 (2004 to 2016) | 1917 | 1831 | 2007 | 106 | |
| BLPR7 (2004 to 2016) | 1826 | 1598 | 2086 | 118 | |
| P414B (2004 to 2008) | 41055 | 38554 | 43720 | 13 | Mine Site averages. Barrick / EM. |
| P417B (2004 to 2008) | 32621 | 29238 | 36395 | 11 | |
| P418B (2004 to 2008) | 44208 | 41971 | 46564 | 13 | |
| PDB1B (2004 to 2008) | 49494 | 48600 | 50404 | 17 | |
| PZ02 (2010 to 2016) | 26170 | 24688 | 27741 | 48 | ESB averages. Barrick / EM. |
| PZ05 (2010 to 2016) | 6064 | 4114 | 8937 | 48 | |
| PZ09 (2013 to 2016) | 24866 | 23188 | 26666 | 15 | |
| PZ10 (2013 to 2016) | 9921 | 8544 | 11519 | 50 | |
| PZ11 (2013 to 2016) | 13444 | 11896 | 15193 | 62 | |
| SB01 (2011 to 2012) | 13258 | 12404 | 14171 | 60 | |
| SB02 (2011 to 2012) | 24150 | 23577 | 24737 | 56 | |
| BCPB Bore1 | 2210 | | | 98 | BCPB Pumping Bores 1 to 4. Barrick / EM. |
| BCPB Bore2 | 2060 | | | 90 | |
| BCPB Bore3 | 1950 | | | 94 | |
| BCPB Bore4 | 3690 | | | 93 | |
| BLPR2 | 1350 | | | 116 | Coffey report G255/18-AD (1994). Sampled 6 Jan 1994. |
| BLPR2 | 1500 | | | 116 | Coffey report G255/18-AD (1994). Sampled 6 Mar 1994. |
| BLPR2 | 1550 | | | 116 | Coffey report G255/24-AJ (1994). Sampled 12 Apr 1994. |
| BLPR2 | 1540 | | | 116 | Coffey report G255/24-AJ (1994). Sampled 24 Nov 1994. |
| BLPR4 | 2020 | | | 102 | Coffey report G255/24-AJ (1994). Sampled 12 Aug 1994. |
| BLPR5 | 610 | | | 114 | Coffey report G255/24-AJ (1994). Sampled 12 Aug 1994. |
| BLPR7 | 1820 | | | 118 | Coffey report G255/24-AJ (1994). Sampled 12 Aug 1994. |
| GW036524 | 50300 | | | 15 | NSWOW Piezometers (Anderson et al. 1993 and NSWOW records). |
| GW036528 | 35100 | | | 10 | |
| GW036528 | 22700 | | | 38 | |
| GW036528 | 10570 | | | 51 | |
| GW036528 | 9990 | | | 51 | |
| GW036551 | 35900 | | | 4 | |
| GW036551 | 24700 | | | 27 | |
| GW036551 | 2750 | | | 40 | |
| GW036552 | 11000 | | | 33 | |
| GW036552 | 615 | | | 64 | |
| GW036552 | 1451 | | | 101 | |
| GW036553 | 2100 | | | 85 | |
| GW036553 | 1850 | | | 121 | |
| GW036553 | 1846 | | | 121 | |
| GW036554 | 17000 | | | 13 | |
| GW036554 | 1050 | | | 43 | |
| GW036554 | 351 | | | 56 | |
| GW036563 | 39600 | | | 19 | |
| GW036594 | 45600 | | | 13 | |
| GW036594 | 27400 | | | 70 | |
| GW036595 | 14490 | | | 86 | |
| GW036595 | 14300 | | | 86 | |
| GW036596 | 3100 | | | 85 | |
| GW036597 | 544 | | | 18 | |
| GW036597 | 2370 | | | 78 | |
| GW036597 | 1864 | | | 95 | |
| GW036609 | 1990 | | | 106 | |
| GW036610 | 14550 | | | 64 | |
| GW036611 | 1857 | | | 109 | |
| GW036611 | 1655 | | | 109 | |
| GW036613 | 31700 | | | 48 | |

Green shading indicates single measurement only.

* in log space.

Appendix E - Pumping Bores

Bland Creek Palaeochannel Pumping Bore Manifest (excludes basic rights bores, and includes only those in the model domain).

Table 1. Active Pumping Bores in the Model Domain.

| Bore Number and/or Name | Owner | Easting (mMGA) | Northing (mMGA) | Ground Elevation (mAHD) | Collar Elevation (mAHD) | Screen Interval (mbgl) | | Screened Stratum | Allocation (ML/year) | Comment |
|--------------------------|-----------|----------------|-----------------|-------------------------|-------------------------|------------------------|------------------|------------------|--|---|
| | | | | | | From | To | | | |
| Bore1 (GW701660) | Evolution | 553276 | 6287386 | 209.7 | 210.4 | 95 | 116 | Ln | 3650 | BCPB. Commenced 2004. |
| Bore2 (GW701659) | | 553071 | 6285635 | 208.7 | 209.4 | 92 | 125 | Ln | | |
| Bore3 (GW701658) | | 555360 | 6283678 | 209.4 | 210.1 | 107 | 128 | Ln | | |
| Bore4 (GW701657) | | 552408 | 6282736 | 208.5 | 209.2 | 108 | 117 | Ln | | |
| SB01 (GW703944) | | 555740 | 6287128 | 210.7 | 211.3 | 54 | 66 | LC | ESB. Commenced February 2010 | |
| SB02 (GW703943) | | 556315 | 6288003 | 210.6 | 211.5 | 45 | 66 | UC/LC | | |
| GW029094 (Billabong 1) | Private | 547041 | 6267503 | | | 100 | 107 | Ln | 2000 | Decommissioned in March 2006. To have been replaced by Billabong 5 in 2008. |
| GW057974 (Billabong 2) | | 547180 | 6268021 | | | 96 | 108 | Ln | | Decommissioned in March 2004. To have been replaced by Billabong 5 in 2008. |
| GW701646 (Billabong 3) | | 545012 | 6265729 | | 208.0 | 98 | 109 | Ln | | Decommissioned in late 2008. Replaced by Billabong 6. |
| GW702127 (Billabong 4) | | 542922 | 6259675 | | 210.0 | 108 | 123 | Ln | Commenced October 2005. Replacement for Billabong 1 and Billabong 2. | |
| GW703639 (Billabong 6) | | 545000 | 6265720 | | | 98 | 110 | Ln | Commenced after 30 June 2008. Replacement for Billabong 3. | |
| GW701267 (Maslin) | | 552731 | 6266198 | | | | 125 ¹ | Ln | 2000 | |
| GW701454 (QuandiallaTWS) | | 557158 | 6240472 | | | 98 | 106 | Ln | 266 | |
| GW701958 (Muffet) | | 556272 | 6270630 | | | 88 | 93 | Ln | 100 | Sandpack from 87m to 95m bgl. |
| GW702013 (Hart) | | 556515 | 6278585 | | | 102 | 109 | Ln | | |
| GW702262 (Mooramoor) | | 549449 | 6293272 | | 212.8 | 117 | 125 | Ln | | Also known as Koreela / McDonald. |
| GW702286 (Trigalana) | 555900 | 6279959 | | 208.3 | 102 | 113 | Ln | | Also known as the Fuge bore. | |
| Trigalana East | 556501 | 6279959 | | | | 110 ² | Ln | | | |

1. Completed depth (screen details unavailable).

2. Screen base is an estimate based on structure contour surfaces developed for modelling.

Glossary: mbgl denotes metres below ground level. UC denotes Upper Cowra Formation. LC denotes Lower Cowra Formation. Ln denotes Lachlan Formation. SWL denotes standing water level.

Table 2. Pumping Bores In the Model Domain For Which No Usage Data Are Available (Designated Inactive In the Model).

| Bore Number and/or Name | Owner | Easting (mMGA) | Northing (mMGA) | Ground Elevation (mAHD) | Collar Elevation (mAHD) | Screen Interval (mbgl) | | Screened Stratum | Allocation (ML/year) | Comment |
|-------------------------|---------|----------------|-----------------|-------------------------|-------------------------|------------------------|-----------------|------------------|----------------------|---|
| | | | | | | From | To | | | |
| GW701579 (Coles) | Private | 553767 | 6269660 | | | 107 | 111 | Ln | | |
| GW701681 (Warrakimbo) | | 552812 | 6266221 | | | 96 | 111 | Ln | | Used as an observation bore until 2006. |
| GW702100 (Hammond) | | 552407 | 6285421 | | | 107 | 115 | Ln | | |
| GW702230 (Duff) | | 555812 | 6287547 | | | | 66 ¹ | UC/LC | | Pump tested for ESB. |
| GW702285 (Mattiske) | | 553174 | 6286458 | | | 105 | 114 | Ln | 1960 | |
| GW703303 (YerraYerra) | | 555926 | 6278354 | | | 109 | 114 | Ln | | Sandpack from 60 to 115 mbgl. |
| GW703389 (Oakhurst) | | 548300 | 6248113 | | | | 40 ¹ | UC/LC | | |
| GW703638 (Billabong 5) | | 547160 | 6267785 | | | 90 | 108 | Ln | | Replacement for Billabong 1 and 2. |
| Low | | 550000 | 6277500 | | | | | | 2000 | Licence application lodged |
| Tulloch | | 544000 | 6243000 | | | | | | 2000 | Licence application lodged |

1. Completed depth (screen details unavailable).

Glossary: mbgl denotes metres below ground level. UC denotes Upper Cowra Formation. LC denotes Lower Cowra Formation. Ln denotes Lachlan Formation. SWL denotes standing water level.

Bland Creek Palaeochannel Pumping Bores

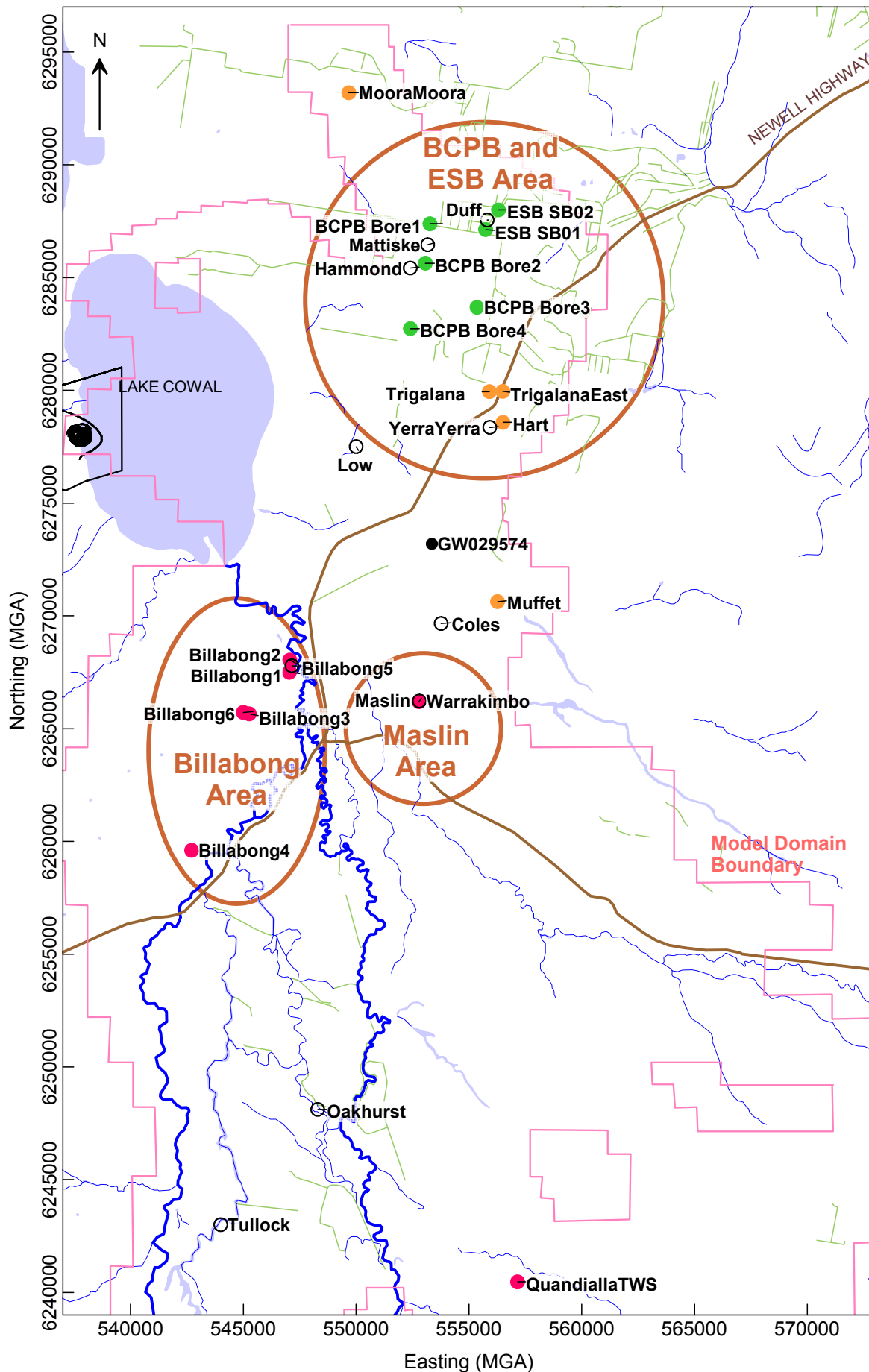

- EM CGO bore (active in model).
- Private bore active in model. Usage data available to June 2010, or decommissioning, whichever earlier (except for Billabong 1, where supplied usage data ends June 2004, but bore was decommissioned in March 2006).
- Private bore active in model. No usage data available but necessarily included in model (from 2007) for calibration and predictive periods. Usage estimates supplied by Lachlan Valley Users Group.
- Private bore inactive in model (no usage data available).

**Appendix F - Bland Creek Palaeochannel Numerical
Groundwater Flow Model**

Table of contents

| | |
|---|---|
| 1. Structure | 1 |
| 2. Boundary Conditions | 4 |
| 2.1. Recharge and Discharge Processes | 5 |
| 3. Media properties..... | 6 |

Tables

Table 1. Calibrated model media properties.

Figures

Figure 1. Model domain boundary.

Figure 2. Layer parameter zones and boundary conditions.

Bland Creek Palaeochannel Numerical Groundwater Flow Model

1. Structure

The model active area covers about 1,800 km². Figure 1 shows the calculated extents of the Upper Cowra, Lower Cowra, and Lachlan Formations, and the boundary of the modelled area (for the uppermost model layer).

Figure 2 shows the modelled areas for each of the three model layers. The total extents of the Cowra and Lachlan Formations (calculated from borehole data and bedrock outcrop) are also shown in Figure 2 as the darker lines. The model areas do not extend to the extremities of the calculated total extents of the sediments since in these areas the sediments in each formation thin out considerably and practical limits were applied to the model boundaries. The model grid consists of a uniform mesh of 50 m by 50 m cells over the Bland Creek Palaeochannel Borefield (BCPB) area (covering an area of about 36 km²) gradually expanding to a maximum cell size of 1 km by 1 km at the edges of the model area. Cell dimensions increase by a factor of 1.2 between cells to maintain model stability and allow accurate calculation of heads.

The groundwater system is simulated using three layers as follows:

- Layer 1: The Upper Cowra Formation (unconfined). The base of the Upper Cowra is set to 47 m below ground level based on hydraulic conductivity (K) data and downhole gamma logs from bores in the vicinity of the BCPB.
- Layer 2: The Lower Cowra Formation (confined / unconfined).
- Layer 3: The Lachlan Formation (confined / unconfined).

The Upper Cowra Formation has one parameter zone (see Figure 2). The Lower Cowra Formation has three parameter zones (northern, central, and southern) of approximately equal extent, broadly based on geology. The Lachlan Formation has two parameter zones representing:

- High K sands and gravels close to and within the deeper parts of the palaeochannel.
- Lower K, finer-grained sediments that generally occur further away from the deeper parts of the paleochannel and surround the high K sands and gravels.

K measurements indicate that bedrock K is probably about 1000 times lower, at the same depth, than the high K part of the Lachlan Formation in the deeper parts of the palaeochannel (about 100 m depth). Therefore, bedrock in the Bland Creek Palaeochannel underlying the alluvial sequence has been assumed to be impermeable for the purpose of numerical simulation, and has not been modelled. This is considered reasonable since the rock occurs at burial depths exceeding 100 m (significantly lowering its hydraulic conductivity), and is separated from the alluvial sequence by a low K clay palaeosol of several metres thickness.

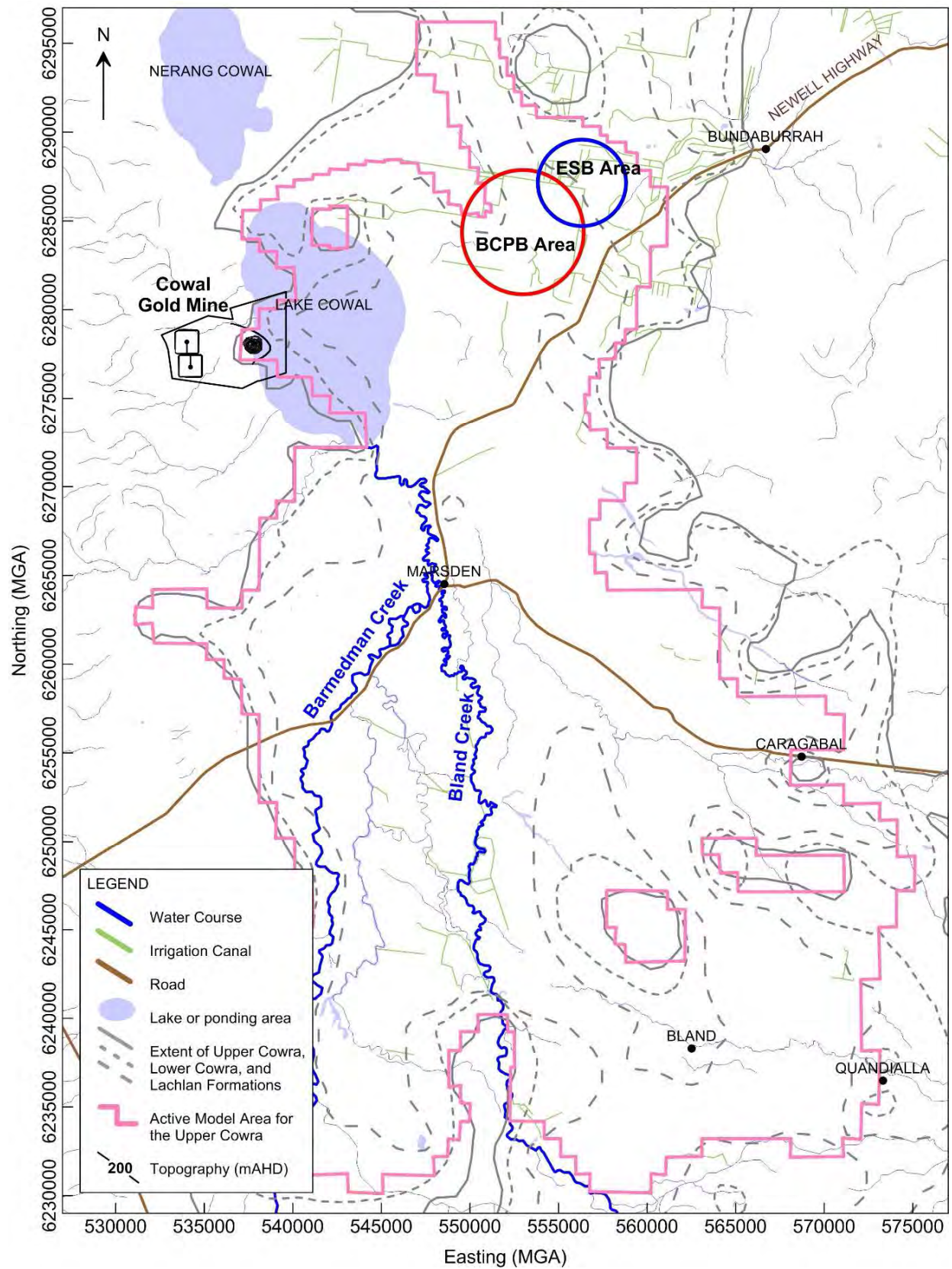
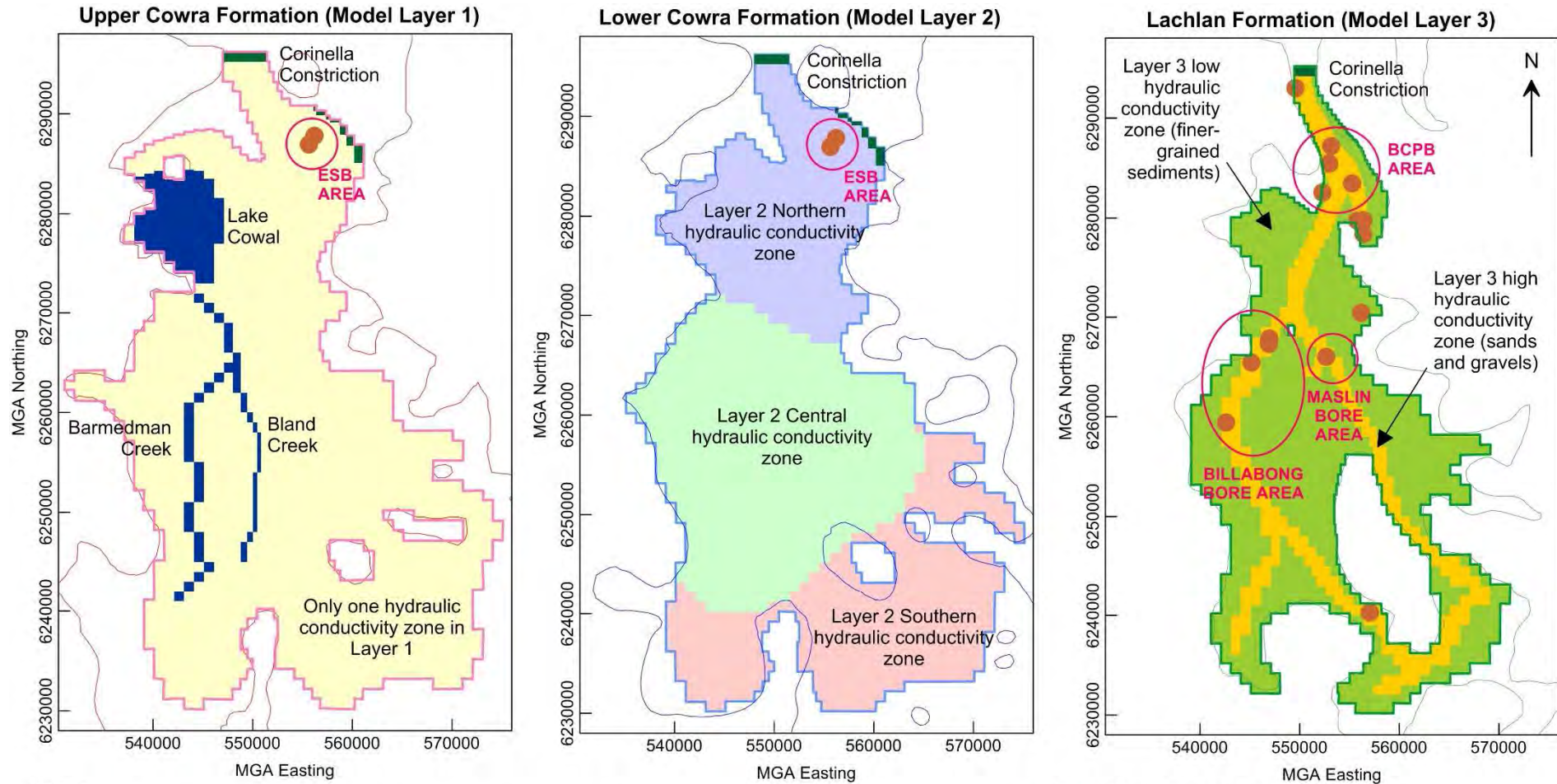

Figure 1. Model domain boundary.



NOTE:

1. Thicker lighter-coloured lines indicate model layer boundaries.
2. Thinner darker-coloured lines indicate interpreted total extents of the formations (to zero thickness).
3. Storativity parameter zones are the same as K parameter zones.

Figure 2. Layer parameter zones and boundary conditions.

2. Boundary conditions

Model boundary conditions are illustrated in Figure 2 and described below.

Rainfall recharge is applied at a uniform percentage of incident rainfall (on a daily, monthly, or yearly basis, depending on stress period size) over the entire extent of the Cowra Formation in the model domain.

The northern boundary of the model was chosen at a point where narrowing of the Bland Creek Palaeochannel is interpreted to occur in the Lachlan Formation at the Corinella Constriction (see Figure 2). Including the area to the north of this point and beyond would have involved the added complexity of treatment of the Lachlan Valley groundwater system and the associated groundwater interactions. To allow groundwater flow across this boundary, a general head condition was applied in all three layers. The general head boundary conditions assigned at this location allow aquifer flow to enter and leave the model at a rate proportional to the difference in head across the boundary.

Parameters for the general head boundaries were initially calculated by assuming that the Lachlan River and Goobang Creek to the north act as ultimate hydraulic controls, and calculating the conductances based on average cell widths, distances to these boundaries from the Corinella Constriction, and estimated layer hydraulic conductivities over this distance. Conductances were then varied slightly during calibration based on the hydrograph for the Koreela bore and government monitoring piezometer GW090093 (see Appendix B of the main report).

Based on a review of stream flow and river stage data from the Government Pinneena database, and field observations, the following water courses have been included in the model using the River package:

- Barmedman and Bland Creeks near Lake Cowal.
- Lake Cowal.

These water courses were selected based on groundwater hydrographs and duration of water flow. Riverbed elevations were assessed from topographic maps, digital elevation data, and stream gauging station survey information. These data were used to assign smoothly-varying riverbed elevations over the model area for the creeks and Lake Cowal. River water level heights were obtained from the Pinneena database. Water levels for Lake Cowal were estimated from data presented in the Cowal Gold Project Environmental Impact Statement (North Limited 1998).

Leakage from Lake Cowal is expected to flow in a northwesterly direction, out of the model active area. To the northwest of Lake Cowal lies Nerang Cowal and a thin cover of surface soil overlying rock. In the model, flow of lake leakage is not possible from the lake to the northwest (because the Upper Cowra Formation is not present there), therefore the calibrated conductance of the lake bed material allows only that flow which reports to the active area of the Upper Cowra Formation in the model.

The CGO Western Saline Borefield (WSB) is located in the mine lease and is included in a separate local groundwater model for the mine lease area, and is not included in the regional model of the current work. The WSB pumps from the Upper Cowra Formation only, at relatively small rates, and is considered unlikely to significantly affect drawdown in the Upper Cowra, Lower Cowra, or Lachlan Formations further east.

The CGO mine pit is included in the separate local groundwater model and is not included in the regional model. The mine pit is located on the western margin of the regional model and intersects alluvial sediments, saprolite (clay), and fractured media. The alluvial sediments are the equivalent of

the Upper Cowra Formation. They have been slightly impacted by drainage into the mine pit. The Lower Cowra and Lachlan Formations are not present at the mine site. The drawdown in the Upper Cowra Formation from pit drainage has been small and localised, and is considered unlikely to significantly affect drawdown in the Upper Cowra, Lower Cowra, or Lachlan Formations further east. Drawdown in the saprolite, saprock, and fresh rock from drainage at the mine pit is not likely to influence groundwater processes in the active model area, apart from the localised effect near the pit of inducing vertical drainage from the Upper Cowra Formation (in addition to lateral drainage towards the pit face).

18 pumping bores are active in calibration, verification, or predictive model simulations. These comprise six Evolution bores (4 at the BCPB and 2 at the ESB) and 12 private bores. Appendix E of the main report lists these bores and their details. Low-extraction basic rights bores (used for stock and domestic purposes) are not included.

2.1. Recharge and discharge processes

Model recharge processes are:

- Rainfall recharge.
- Leakage from rivers (Bland Creek and Lake Cowal).
- Flow into the model from the Corinella Constriction in all layers.

Model discharge processes are:

- Groundwater extraction from the Upper Cowra, Lower Cowra, and Lachlan Formations.
- Leakage to rivers (Bland Creek and Lake Cowal).
- Flow out of the model to the Corinella Constriction in all layers.

Evaporation is not modelled because the average depth of the water table in the Upper Cowra Formation is around 5 m over the majority of the model domain, and below the extinction depth typical for the land use, surface lithology, and climate of the area.

Intermittent recharge from flooding from remnant ponds outside the water course channels is not modelled in calibration simulations since no flooding was known to have occurred in the area during the model calibration period. However, the calibrated riverbed conductances and rainfall recharge would incorporate the effect of this process where it may have occurred but was not explicitly identified in observations.

3. Media properties

Calibrated model media properties are listed in Table 1.

Initial estimates for riverbed conductance were based on consideration of values used for river systems in the Lower Namoi Valley groundwater flow model (Merrick 1989). The Lower Namoi Valley and Bland Creek Palaeochannel display many similar characteristics such as climate, subsurface media types, and river types.

Automated parameter estimation conducted as part of the 2006 modelling process indicated that the calibrated values for various parameters were considered defensible and appropriate based on site-specific observations, published studies, and model formulation. A finding of the estimation study was that in the more southerly parts of the model domain the vertical leakance in the Cowra Formation was likely to be lower than the calibrated value of the 2006 model. It was considered that, based on available data, the vertical leakance between the Cowra and Lachlan Formations was likely to decrease in a southerly direction. This finding was taken into account by dividing the Lower Cowra Formation into three zones (northern, central, and southern) of approximately equal extent, broadly based on geology, so that vertical leakance could be varied between zones.

Table 1. Calibrated model media properties.

| Parameter | Model Zone | | | | | |
|--|---------------------|----------------------|-----------------------|----------------------|----------------------------|-----------------------------|
| | Upper Cowra | Lower Cowra (North) | Lower Cowra (Central) | Lower Cowra (South) | Lachlan (Low Conductivity) | Lachlan (High Conductivity) |
| Lateral Hydraulic Conductivity (m/day) | 1 | 2 | 1 | 1 | 3 | 28 |
| Average Thickness over Model Area (m) | 35 | 34 | 34 | 34 | 30 | 30 |
| Average Transmissivity over Model Area (m ² /day) | 35 | 68 | 34 | 34 | 90 | 840 |
| Vertical Hydraulic Conductivity (m/day) | 6 x10 ⁻⁵ | 1 x10 ⁻⁵ | 6 x10 ⁻⁶ | 1x10 ⁻⁵ | 3 | 28 |
| Specific Storage (m ⁻¹) | N/A | 1.5x10 ⁻⁵ | 1.5x10 ⁻⁵ | 1.5x10 ⁻⁵ | 1.5x10 ⁻⁵ | 1.5x10 ⁻⁵ |
| Specific Yield | 0.04 | N/A | N/A | N/A | N/A | N/A |
| General Head Boundaries | | | | | | |
| External Head (mAHD) | 198 | 196 | N/A | N/A | N/A | 196 |
| Conductance (m ² /day) | 1 | 1 | N/A | N/A | N/A | 25 |
| River Bed Conductance (m ² /day): | | | | | | |
| Bland and Barmedman Creeks | 10 | N/A | N/A | N/A | N/A | N/A |
| Lake Cowal | 5 | N/A | N/A | N/A | N/A | N/A |
| Rainfall Recharge (% of average annual rainfall) | 1.0 | N/A | N/A | N/A | N/A | N/A |

Assuming an average river channel width of 20 m (including overbank ponds), an average river reach of 1200 m in each cell, and 0.2 m of barrier material in the river bottom, the calibrated riverbed conductance for Bland and Barmedman Creeks is equivalent to a vertical hydraulic conductivity for the river bed barrier material of 9 x 10⁻⁵ m/day. For Lake Cowal leakage occurs over the entire area of each cell so the riverbed conductance is equivalent to a vertical hydraulic conductivity in the lake bed material of 1 x 10⁻⁶ m/day. This compares favourably with results from laboratory analysis of

lakebed sediments indicating an average vertical hydraulic conductivity of 5.0×10^{-7} m/day (Hawkes 1998), allowing for upscaling from a laboratory sample scale to a regional scale. Hydraulic test results in Hawkes (1998) also indicate an average lateral hydraulic conductivity for the lake bed material of 5.5×10^{-5} m/day for one location on the lake.

Rainfall recharge is calibrated to 1% of annual rainfall and compares favourably with other estimates for the area (between 0.3% and 2%). It is an overall average for the model area, mostly comprising recharge from rainfall and irrigation, but also likely to contain a small component representing seepage from shallow, higher conductivity rock on the fringes of the alluvial sediments. It is also likely that the calibrated value includes the effects of intermittent ponding associated with water courses.

The calibrated specific storage ($1.5 \times 10^{-5} \text{ m}^{-1}$) compares favourably with pump test results (average of around $9 \times 10^{-6} \text{ m}^{-1}$).

Appendix G - Verification Hydrographs

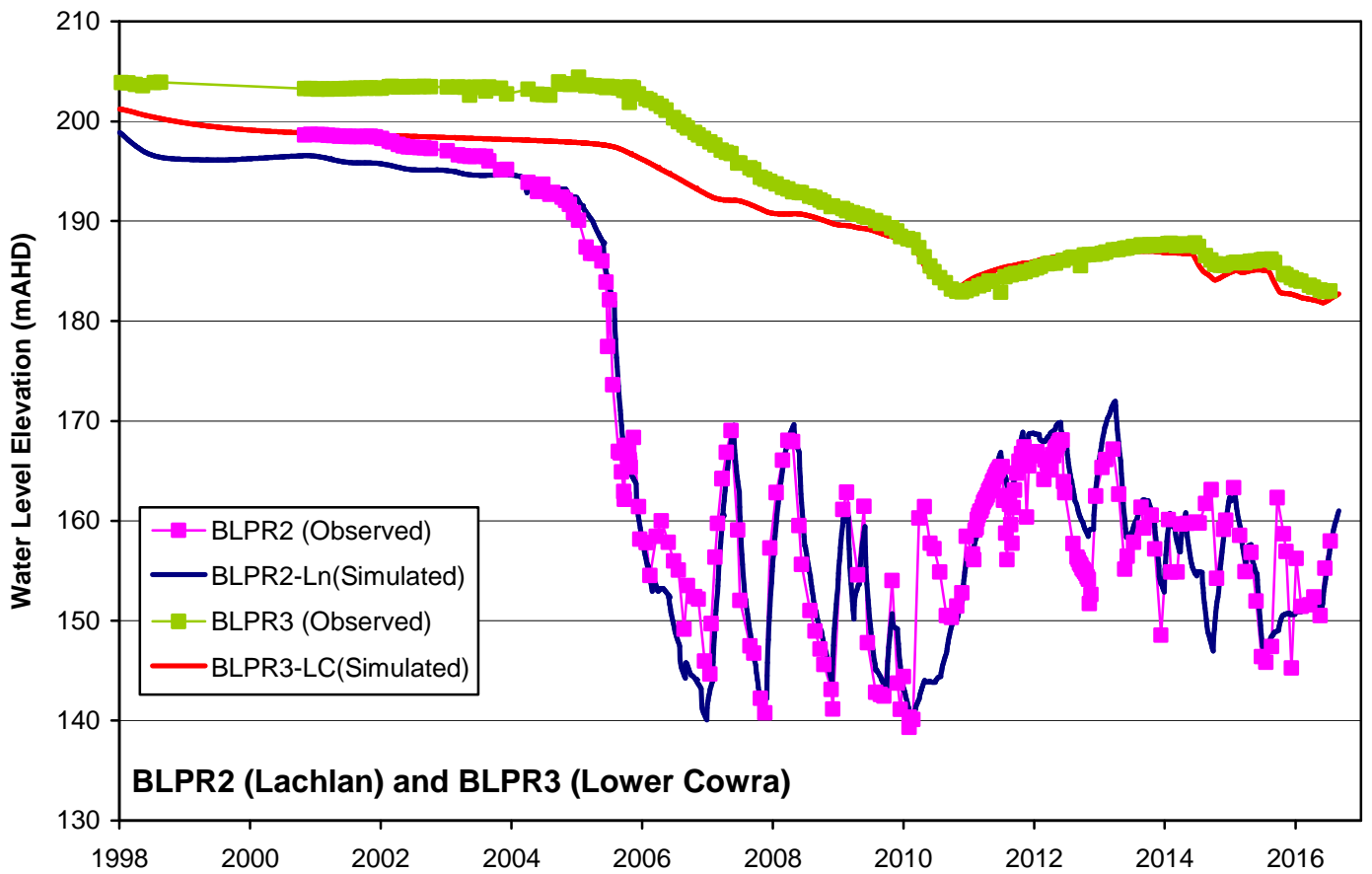
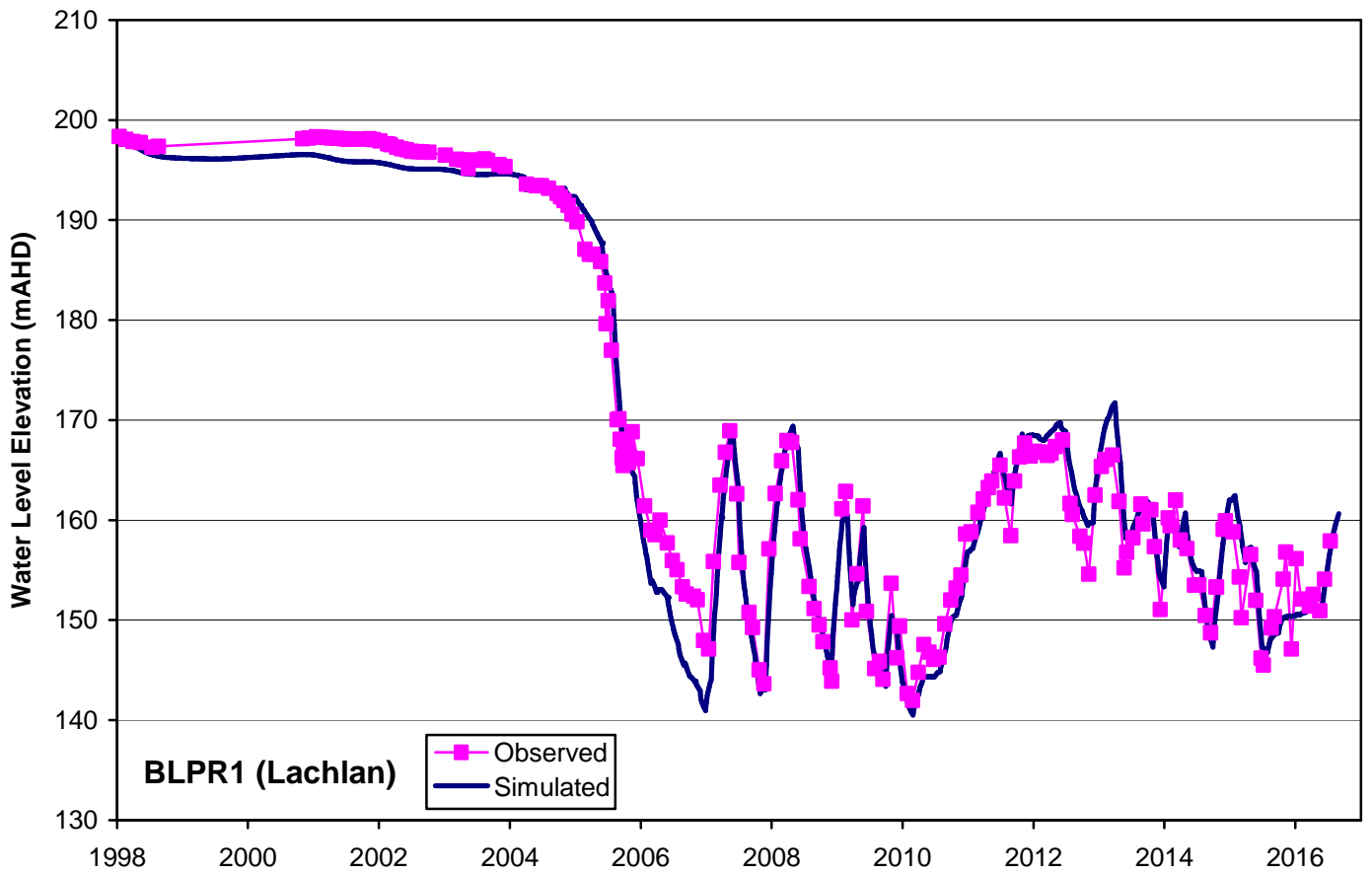

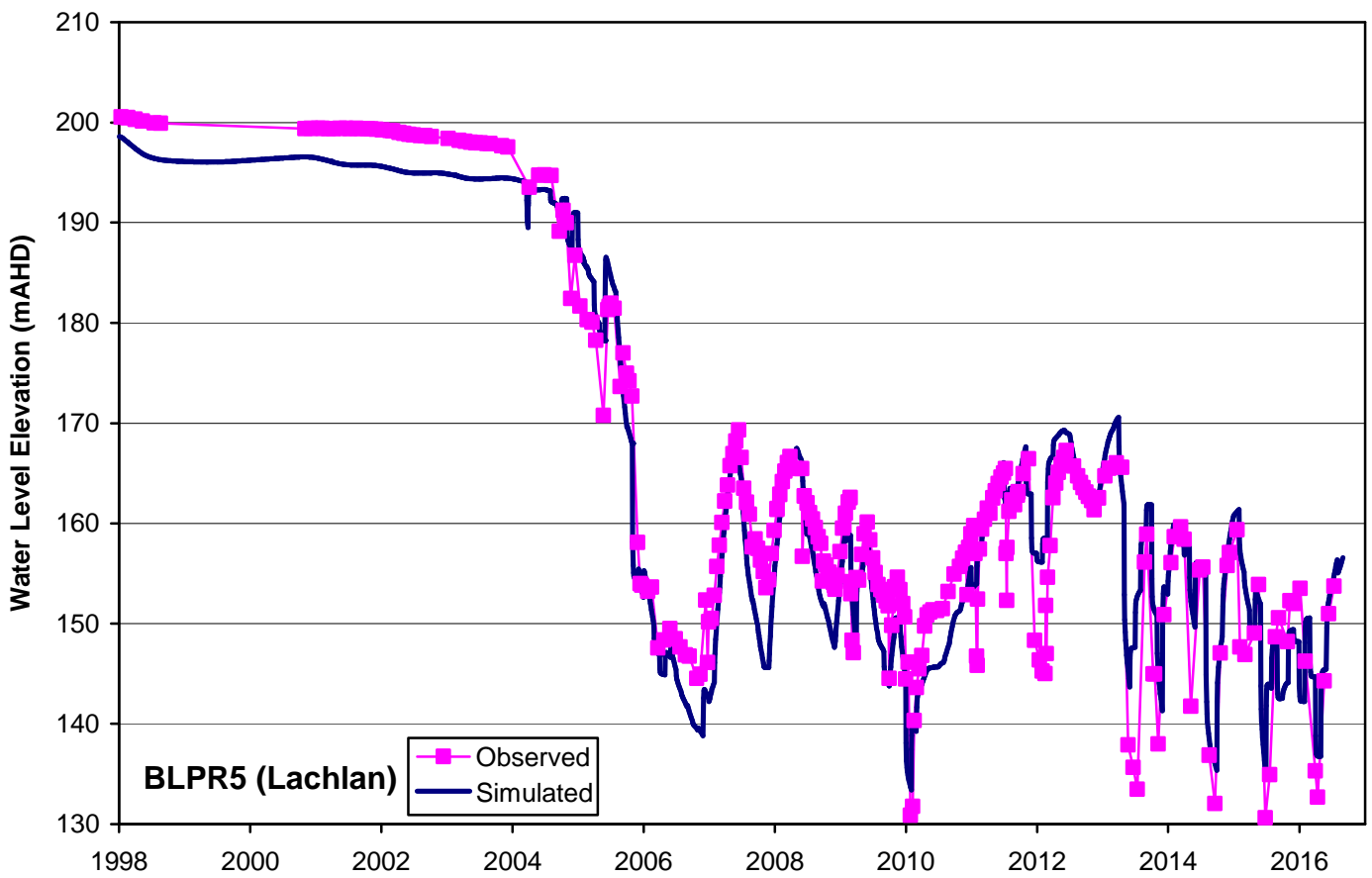
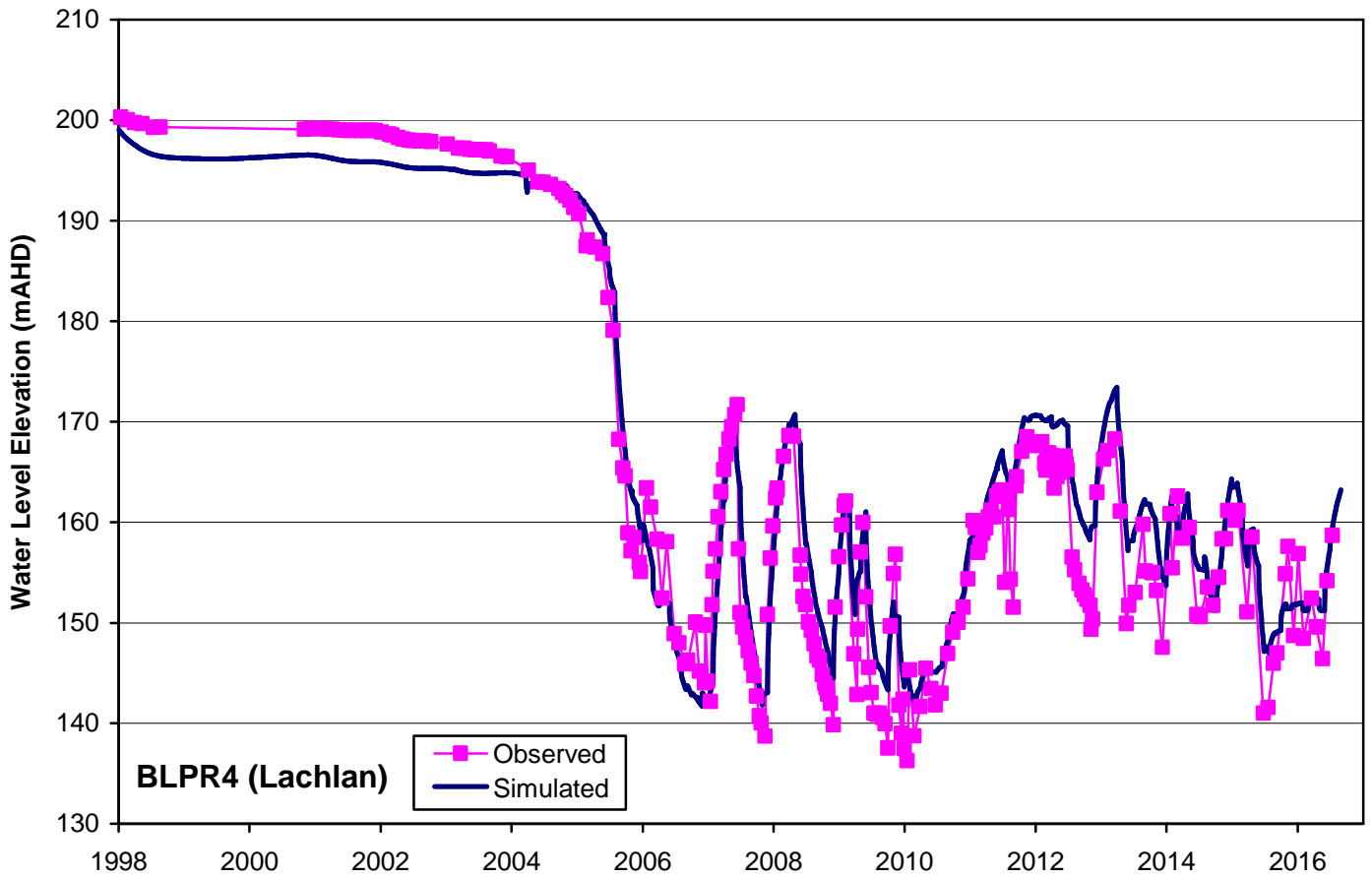

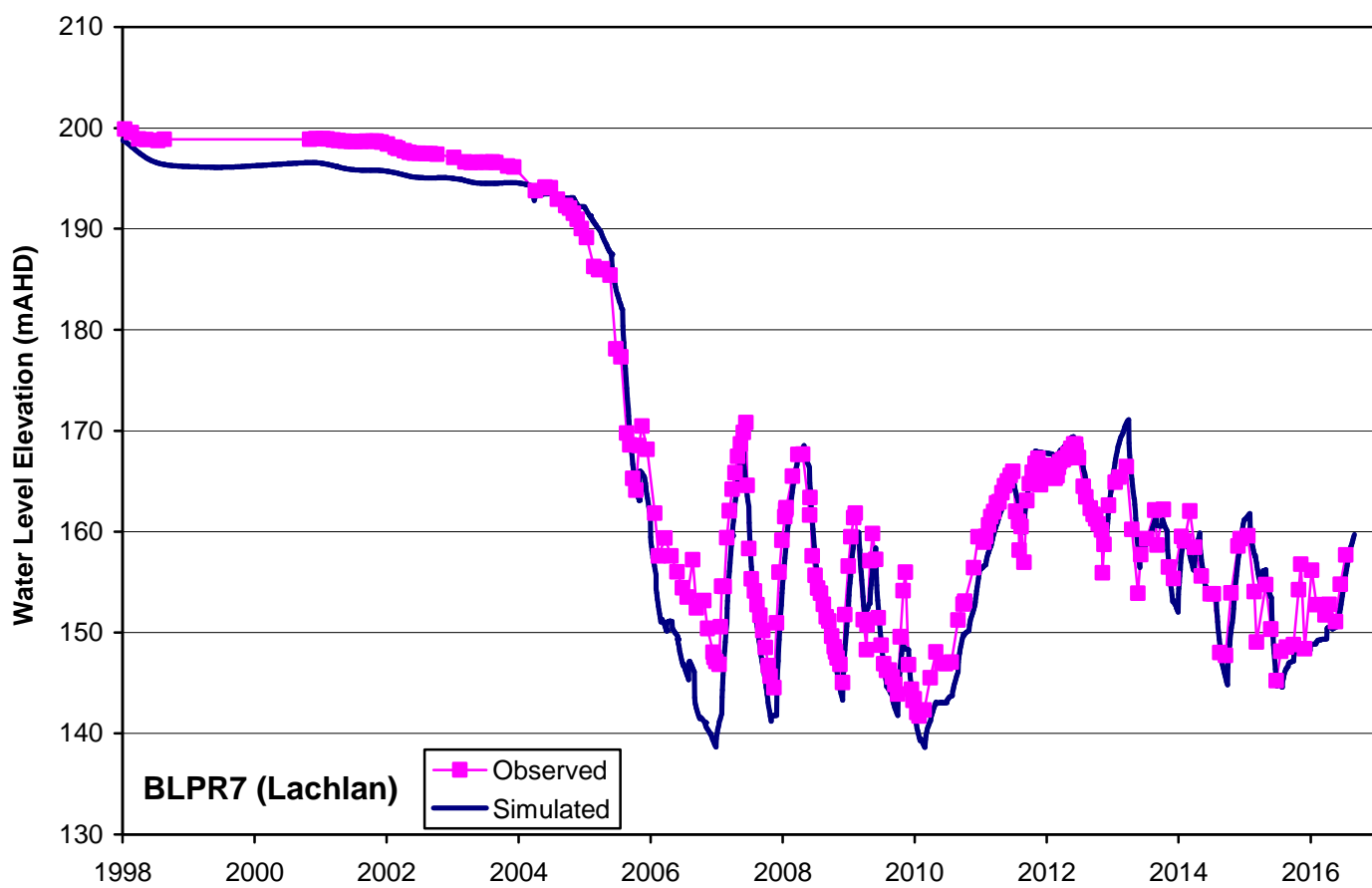
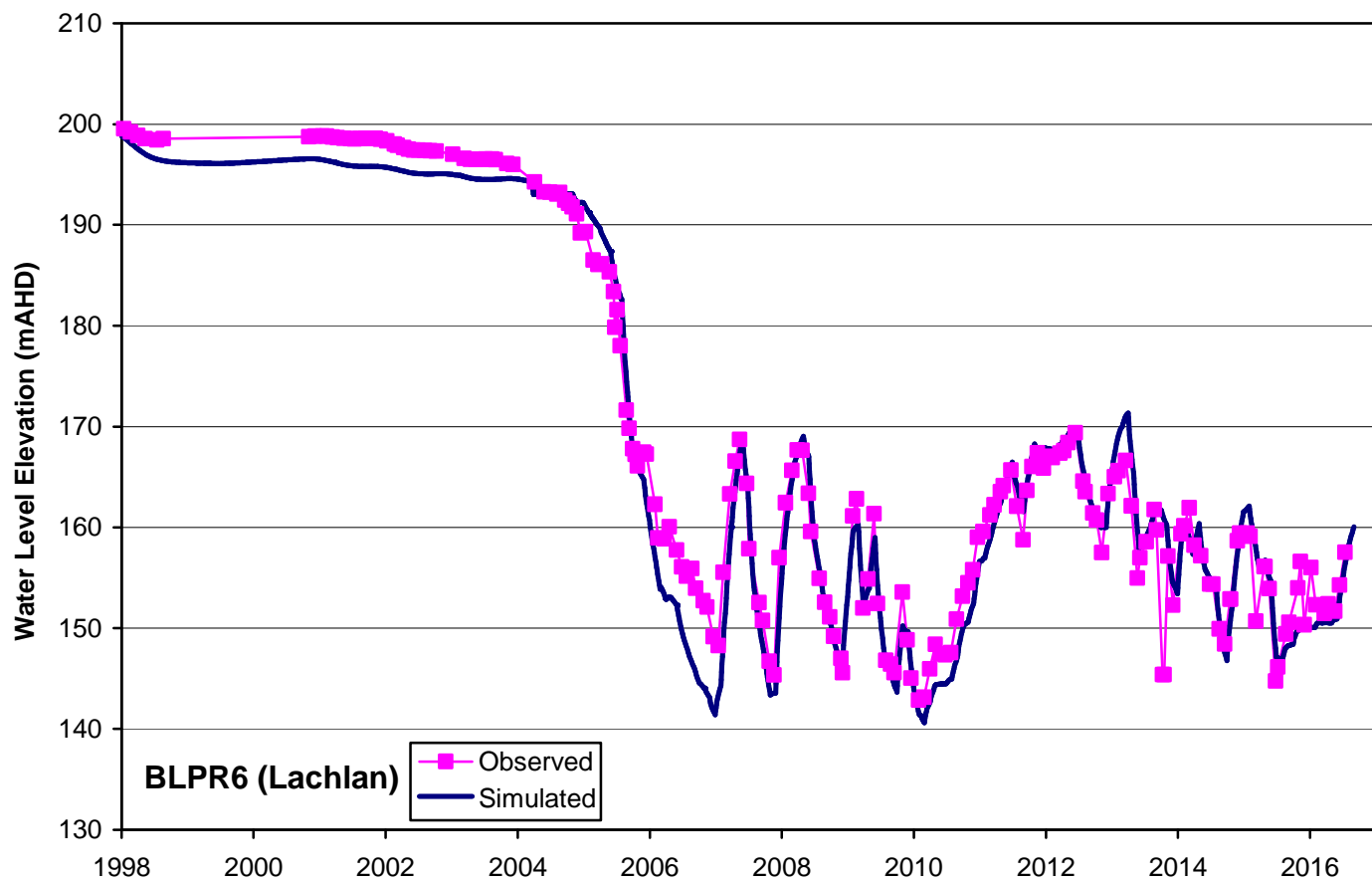

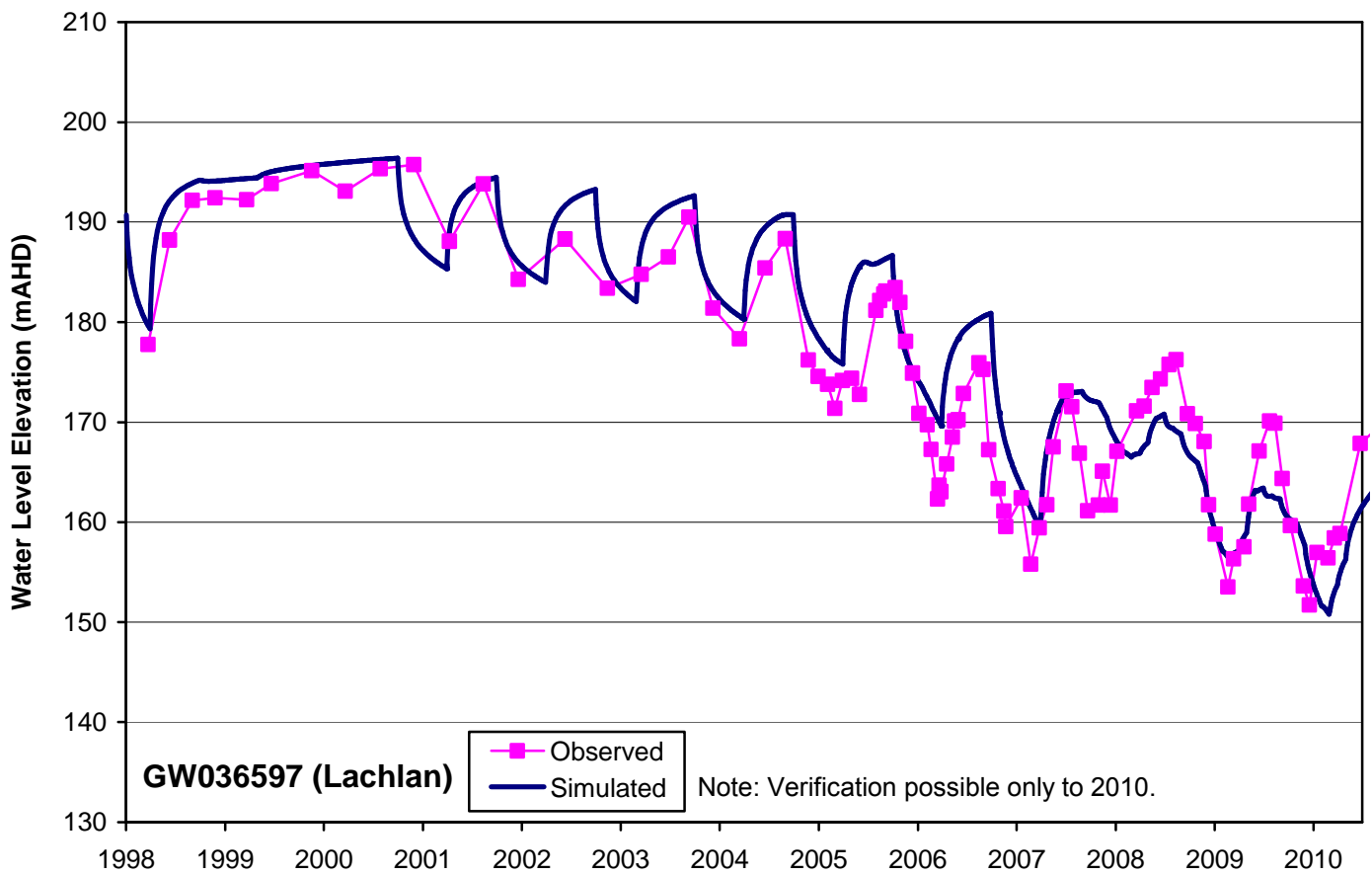
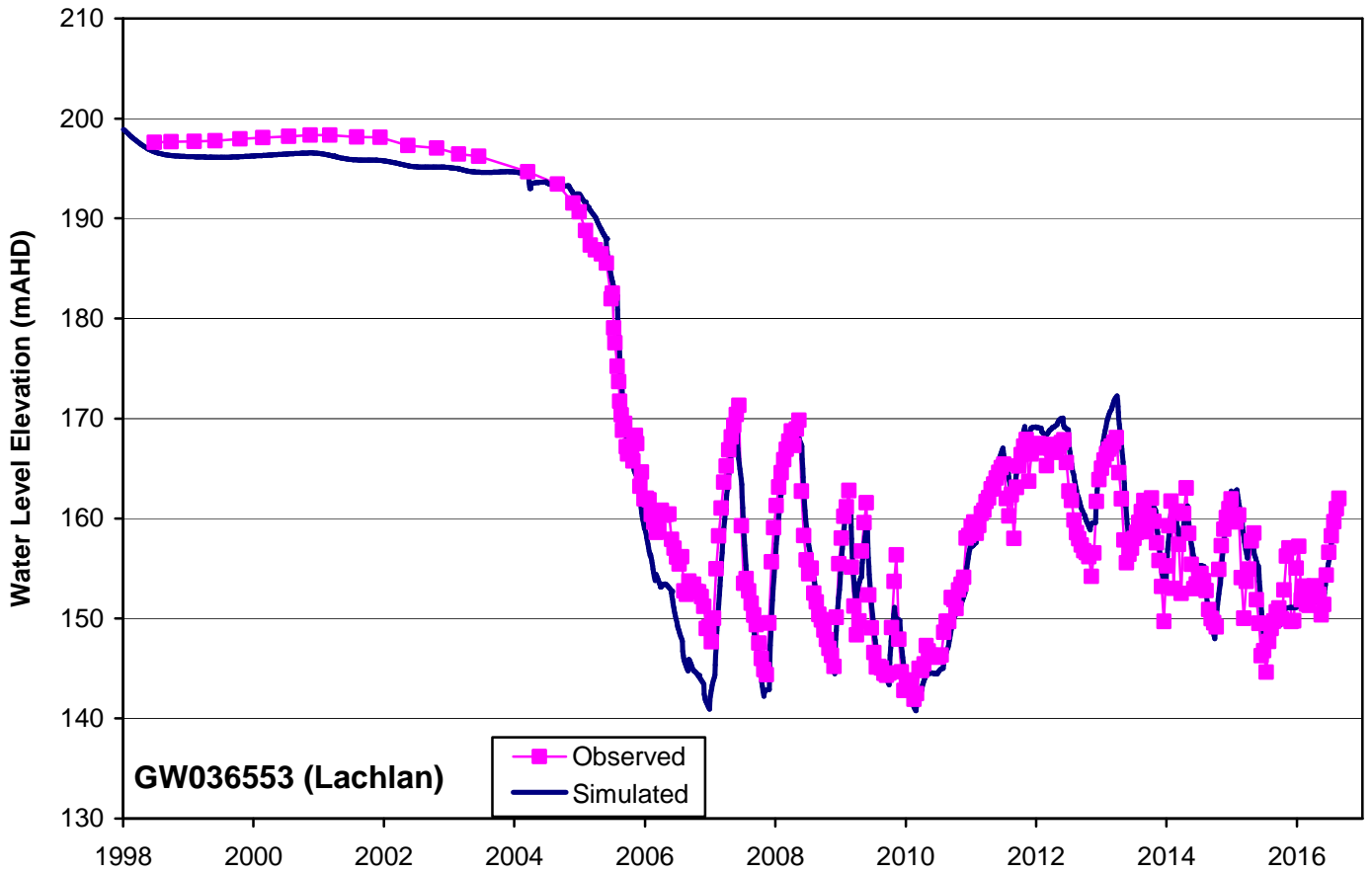

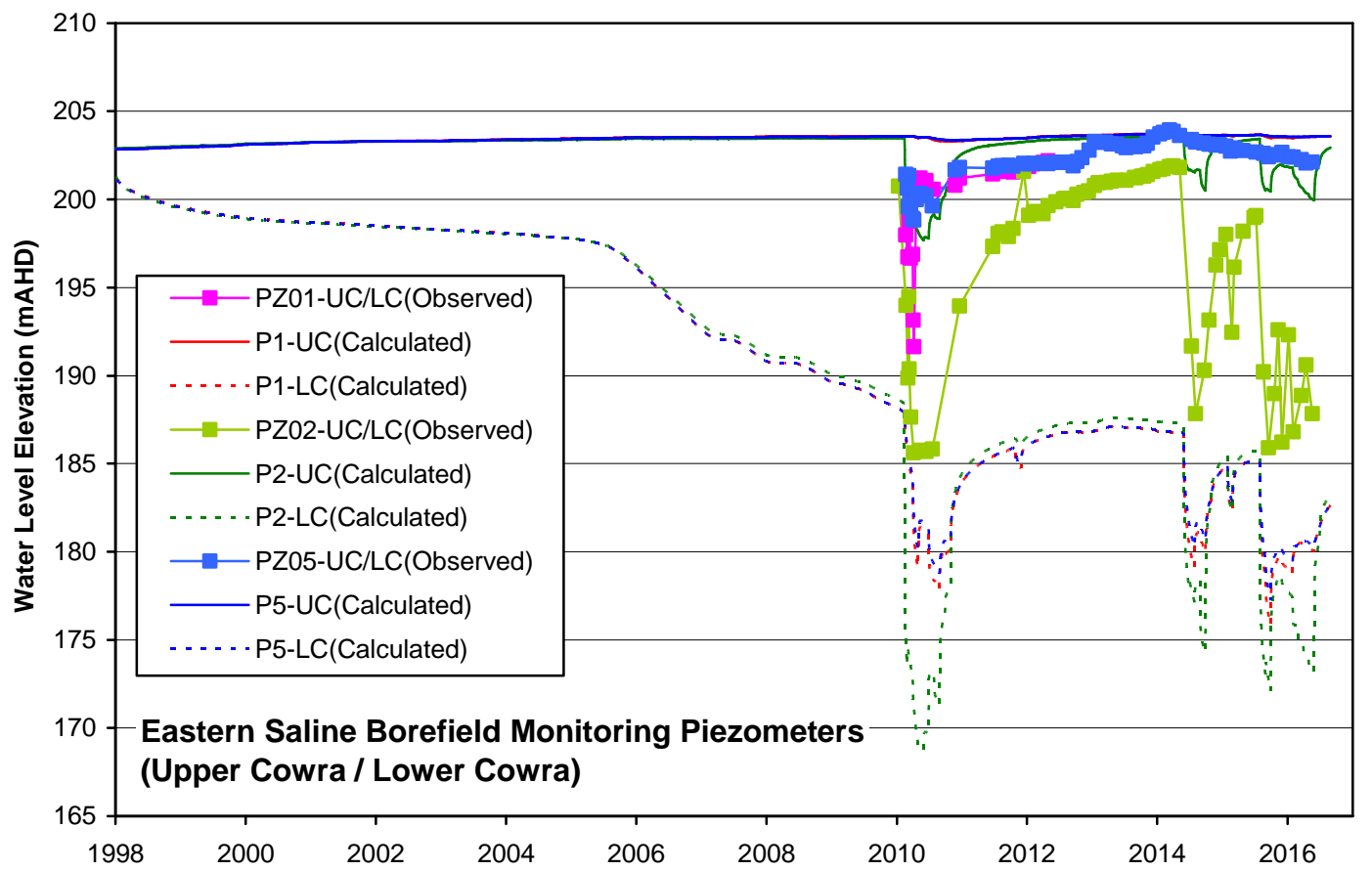
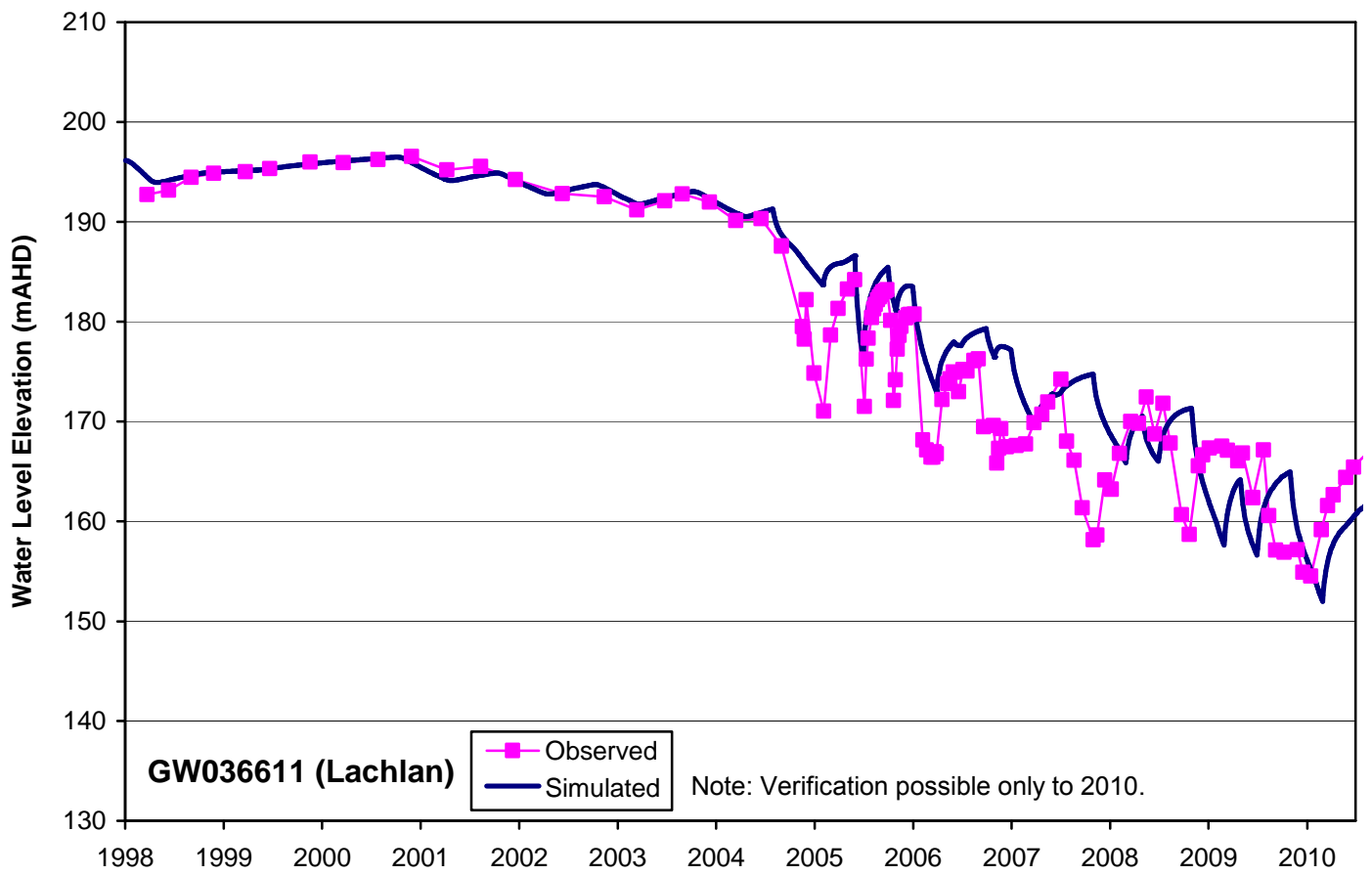

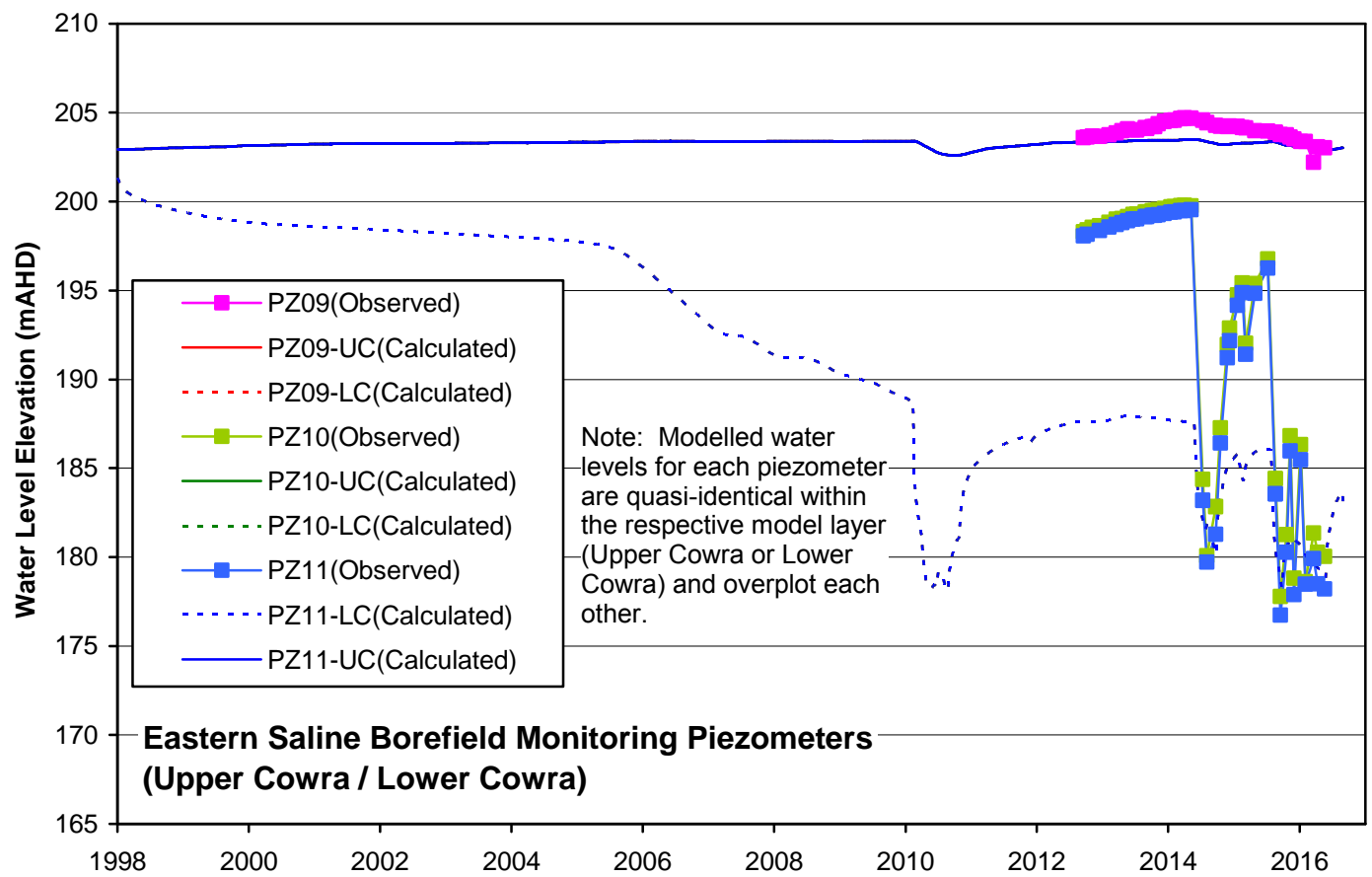
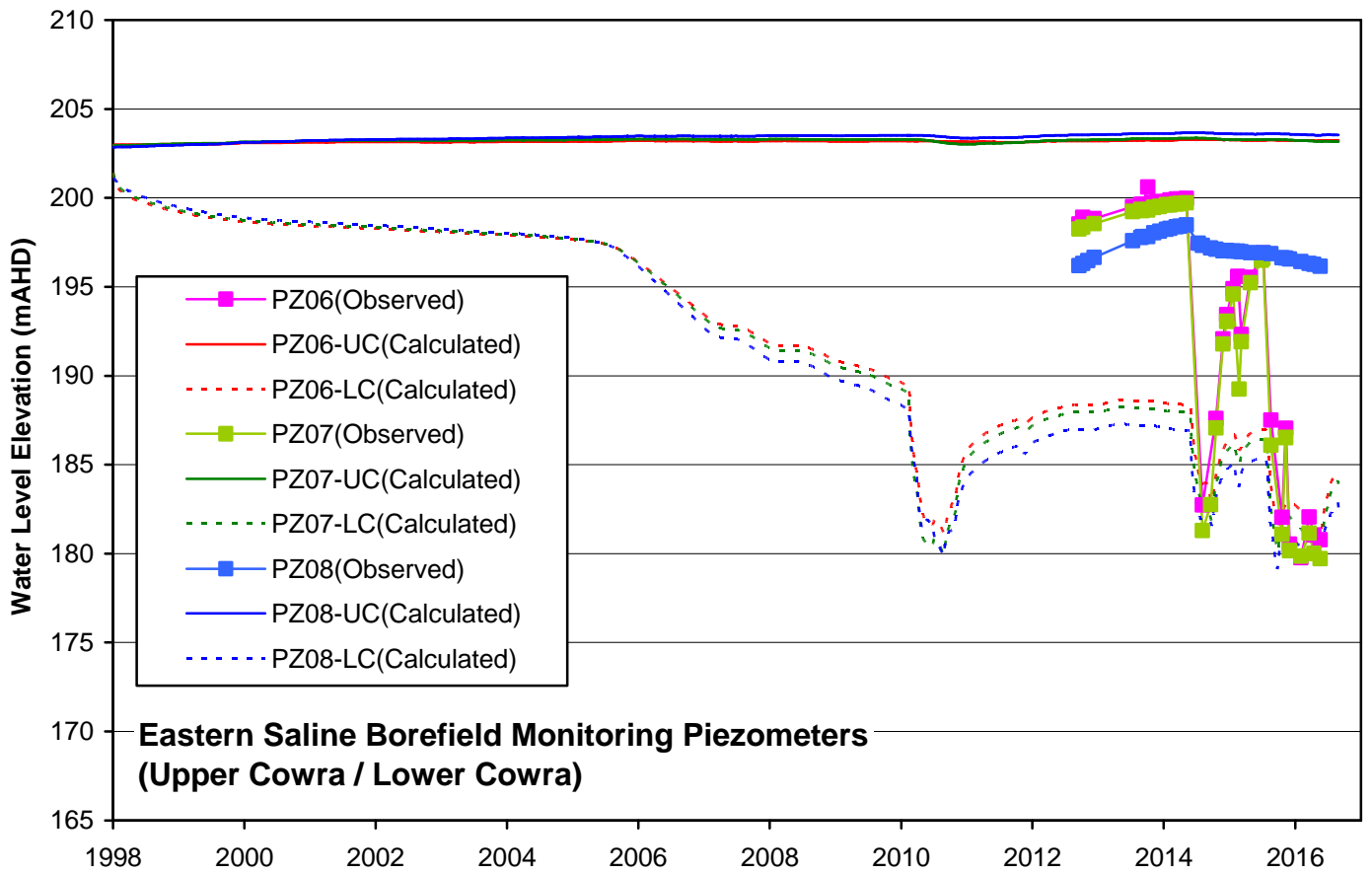

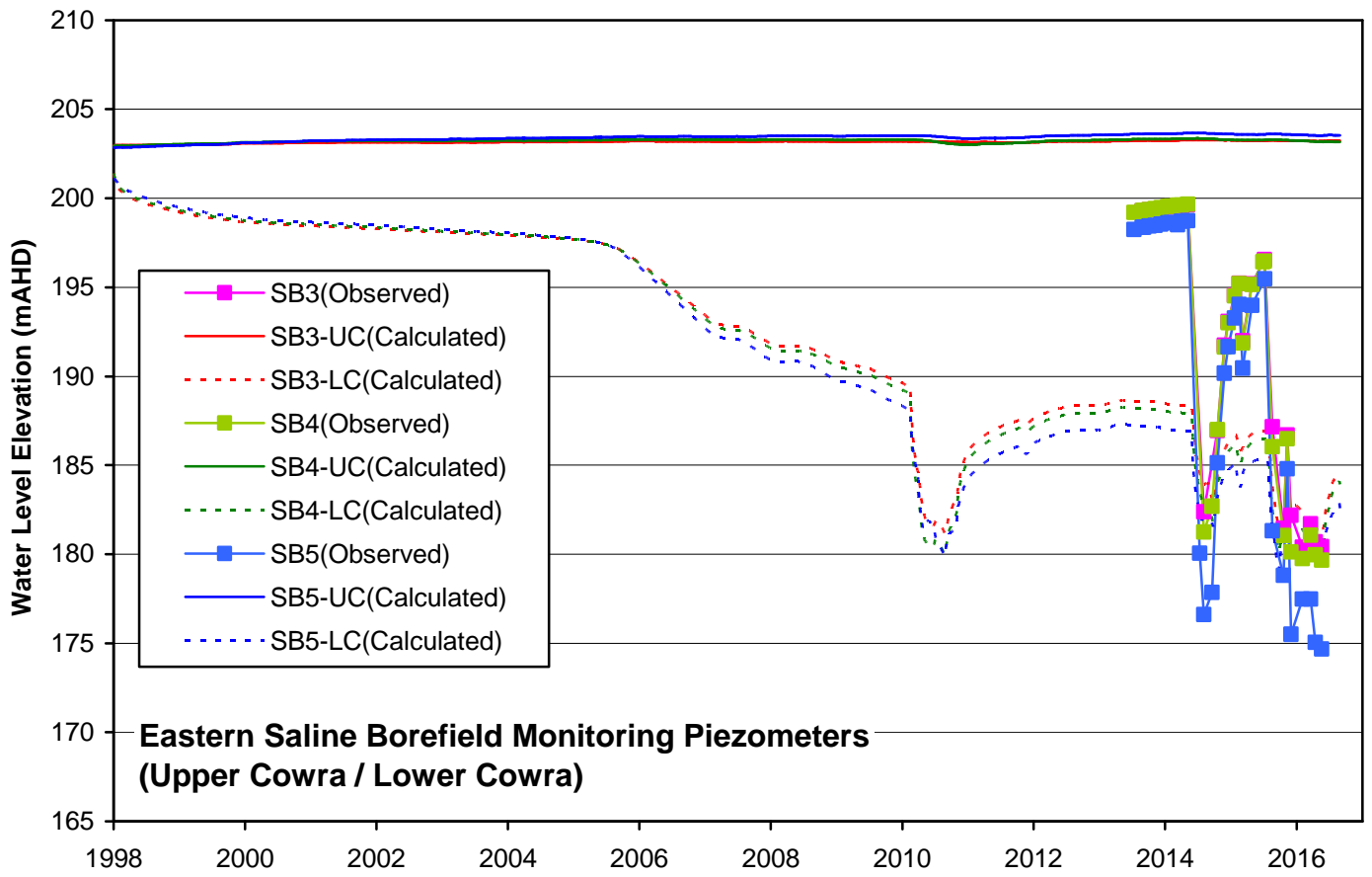

**Appendix H - Drawdown in the Lower Cowra and
Lachlan Formations at the end of BCPB and ESB
Operation (31 Dec 2032)**

Drawdown in the Lower Cowra Formation at the end of BCP and ESB Pumping (31 Dec 2032)

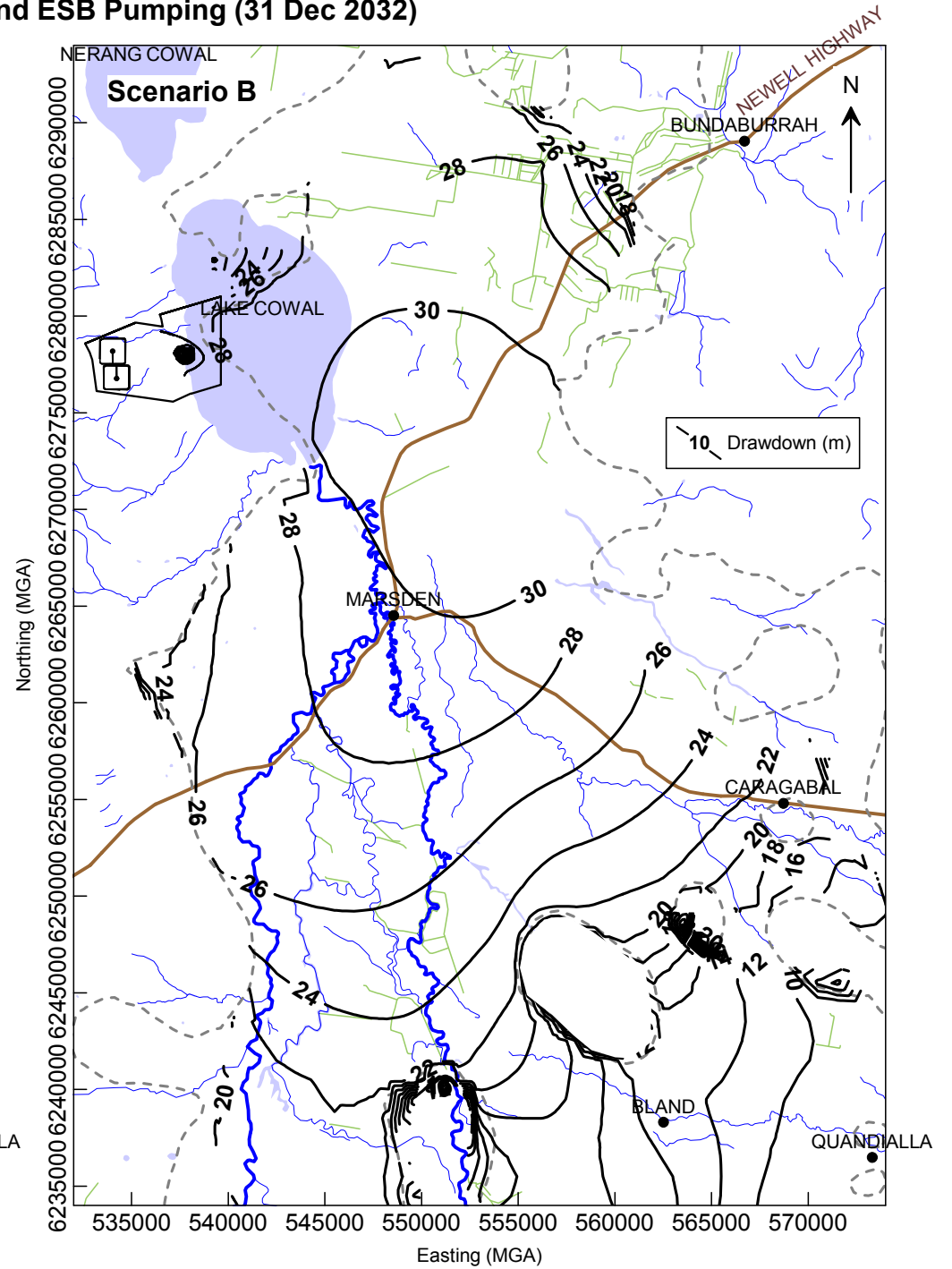
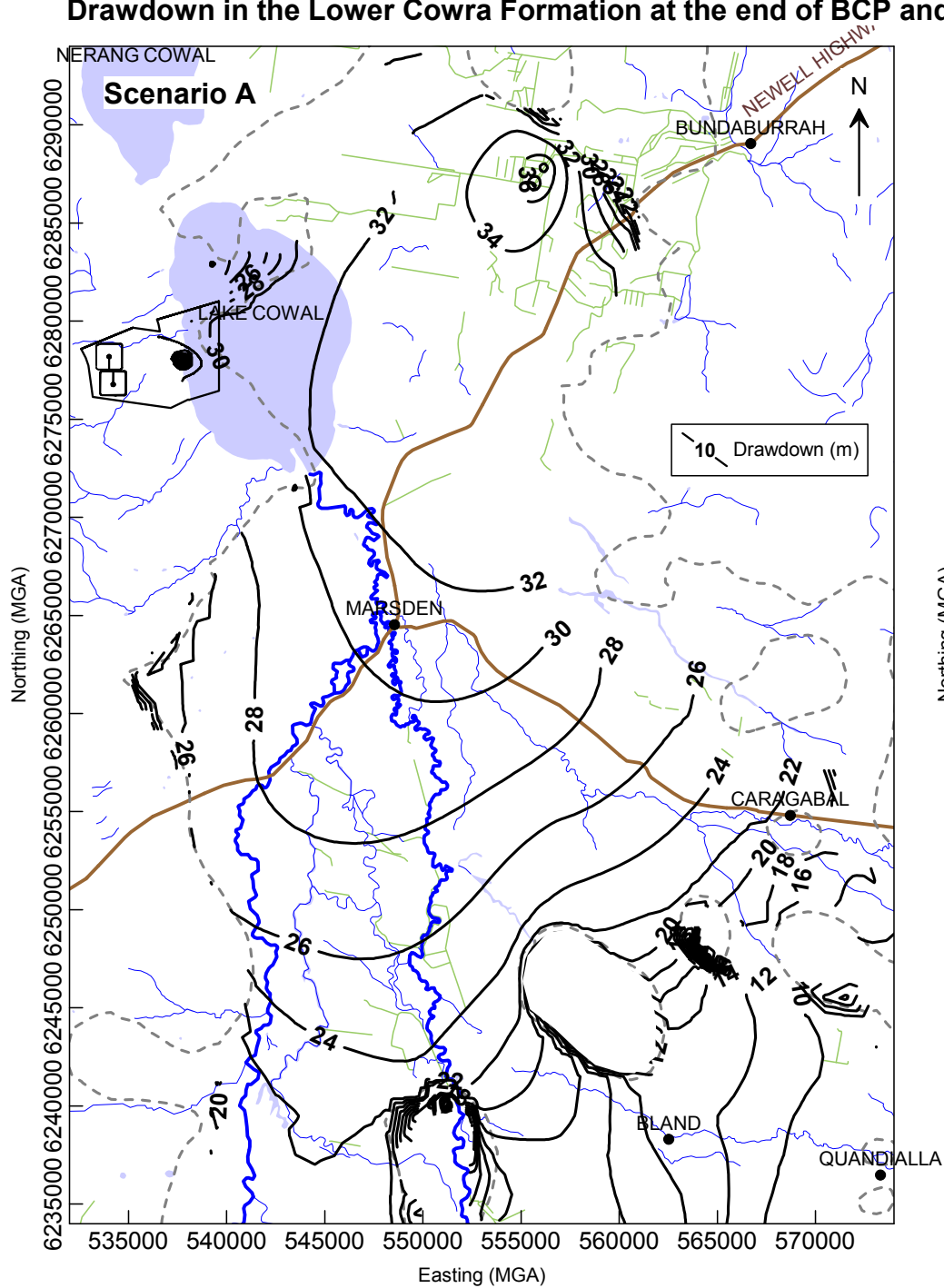

Drawdown in the Lachlan Formation at the end of BCP and ESB Pumping (31 Dec 2032)

